

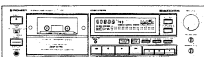

PIONEER
The future of sound and vision.

Service Manual



ORDER NO.
ARP 2009

STEREO CASSETTE DECK

CT-447

CT-447S

MODEL CT-447 AND CT-447-S HAVE FOLLOWING VERSIONS:

Type	Applicable model		Power requirement	Export destination
	CT-447	CT-447-S		
HEM	○		AC 220V, 240V (switchable) *	European continent
HB	○		AC 220V, 240V (switchable) *	United Kingdom
HEWM		○	AC 220V, 240V (switchable) *	European continent

* Change the primary wiring of the power transformer.

- This manual is applicable to the HEM, HB and HEWM types.
- As to the HB and HEWM types, refer to page 40.
- The CT-447-S is the same as the CT-447 except for color.
- Ce manuel pour le service comprend les explications de réglage en français.
- Este manual de servicio trata del método ajuste escrito en español.

CONTENTS

1. PACKING	2	8. ADJUSTMENTS	26
2. EXPLODED VIEWS AND PARTS LIST	3	RÉGLAGE	30
3. IC BLOCK DIAGRAM	9	AJUSTE	34
4. BLOCK DIAGRAM	10	9. IC INFORMATION	38
5. SCHEMATIC DIAGRAM	12	10. FOR CT-447/HB AND CT-447-S/HEWM	
6. P.C. BOARDS CONNECTION DIAGRAM	15	TYPES	40
7. P.C.B'S PARTS LIST	23	11. PANEL FACILITIES	41
		12. SPECIFICATIONS	43

PIONEER ELECTRONIC CORPORATION 4-1, Meguro 1-Chome, Meguro-ku, Tokyo 153, Japan
PIONEER ELECTRONICS SERVICE INC. P.O. Box 1760, Long Beach, California 90801 U.S.A.
PIONEER ELECTRONICS OF CANADA, INC. 505 Cochrane Drive, Markham, Ontario L3R 8E3 Canada
PIONEER ELECTRONIC [EUROPE] N.V. Keelberglaan 1, 2740 Beveren, Belgium
PIONEER ELECTRONICS AUSTRALIA PTY. LTD. 178-184 Boundary Road, Braeside, Victoria 3195, Australia TEL: [03] 580-9911
 © PIONEER ELECTRONIC CORPORATION 1990

SEI APR. 1990 Printed in Japan

1. PACKING

Parts List

Mark	No.	Description	Parts No.
	1	Pad (A)	RHA1006
	2	Pad (B)	RHA1007
	3	-----	
	4	Packing case	RHG1197
	5	Sheet	RHX-034
	6	Control code	RDE1018
	7	Operating instructions (English)	RRB1062
	8	Operating instructions (Spanish)	RRD1077
	9	Control code	RDE-010
	10	Control code (MINI)	RDE-319

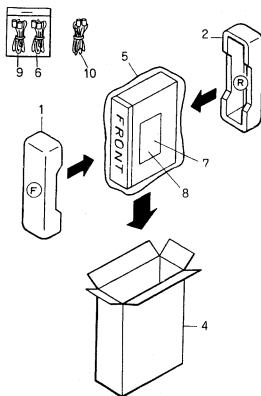

2. EXPLODED VIEWS AND PARTS LIST

NOTES:

- Parts without part number cannot be supplied.
- The Δ mark found on some component parts indicates the importance of the safety factor of the part. Therefore, when replacing, be sure to use parts of identical designation.
- Parts marked by * are not always kept in stock. Their delivery time may be longer than usual or they may be unavailable.

2.1 Parts List of Exterior

Mark	No.	Description	Parts No.	Mark	No.	Description	Parts No.
Δ	1	Strain relief	OM-22B		36	VR escutcheon	RNK1318
Δ	2	Power cord	PDG1003		37	Screw	ABZ26P060FMC
Δ	3	Fuse (FU), FU2, 1.25A)	REK-101		38	Screw	ABZ30P060FMC
Δ	4	Power transformer (T1)	RTT1137		39	Screw	BBZ30P060FZK
	5	Connector (3P)	RKP1360		40	Screw	BBZ26P060FZK
	6	Ratchet spring	RBH1008		41	Screw	BBZ30P040FMC
	7	Door spring (L)	RBH1134		42	Screw	IBZ30P060FCC
	8	Push spring	RBH1146		43	Screw	BBZ30P060FMC
	9	Half pressure spring	RBK1004		44	Screw	BBZ30P100FZK
	10	Connector (2P)	RKP1361		45	Screw	BBZ30P060FCC
	11	Damper ass'y	REC1005		46	Screw	BCT26P100FZK
	12	Knob (PHONES LEVEL)	RAC1416		47	Screw	BPZ20P060FMC
	13	Insulator	VNK1095		48	Screw	FBT40P060FZK
	14	Knob (COUNTER RESET)	RAA1009		49	Screw	IBZ30P150FCU
	15	Knob (A) (TIMER)	RAC-666		50	Screw	PMA30P060FCU
	16	Knob (AUTO BLE, LEVEL METER, WIDE/EXPND)	RAC1218		51	Binder	REC-265
	17	Knob (REC LEVEL)	RAC1363		52	Blinder	REC-371
	18	Knob (◀, ▶, ►, ●, II, ○)	RAC1362		53	Front panel ass'y	RXX1293
	19	Knob (EJECT)	RAC1361		54	Bonnet	RXX1292
	20	Knob (CD SYNCHRO, DOLBY ON/OFF, B/C TYPE)	RAC1230		55	Stopper	VEC1061
	21	Knob (POWER)	RAC1364		56	Screw	BBZ30P060FZK
	22	Knob (REC BALANCE)	RAC1366		101	Main unit	
	23	Knob (COUNTER MODE, BLANK SEARCH)	RAC1349		102	Display unit	
	24	Cassette plate	RAH1234		103	Control SW unit	
	25	----- plate			104	VR unit	
	26	Screw	RAT1001		105	Headphone unit	
	27	Stabilizer (B)	REB1038		106	Timer SW unit	
	28	Remain display paper	REE-113		107	Transformer 1 unit	
	29	Door pocket	RNT1010		108	Power SW unit	
	30	Button panel	RAH1680		109	Transformer 2 unit	
	31	Door lens	RAH1244		110	Mechanism unit	
	32	Meter lens	RAH1246		111	PCB spacer	
	33	FL filter	RAH1245		112	Bonnet cushion	
	34	Door panel	RAH1678		113	Main chassis	
	35	Eject mold	RNK1313		114	Headphone bracket	
					115	Mechanism stay	
					116	Side stay	
					117	Center stay	
					118	Name plate	
					119	Front panel	
					120	Rear panel	
					121	Door fulcrum mold	
					122	-----	
					123	Regulator IC unit	
					124	HX unit	

2.1 EXTERIOR

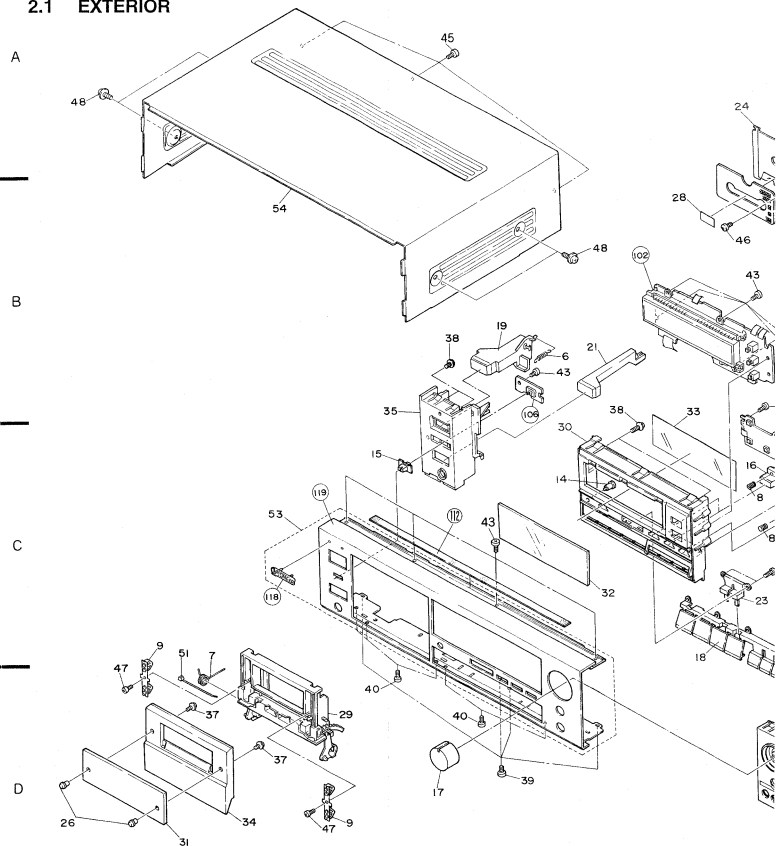

2.1 EXTERIOR

- 10FMC
- 10FMC
- 10FZK
- 10FZK
- 10FMC
- JFCC
- 10FMC
- 10FZK
- 10FZK
- 10FZK
- JFCU
- 60FCU

10FZK

A

B

C

D

A

B

C

D

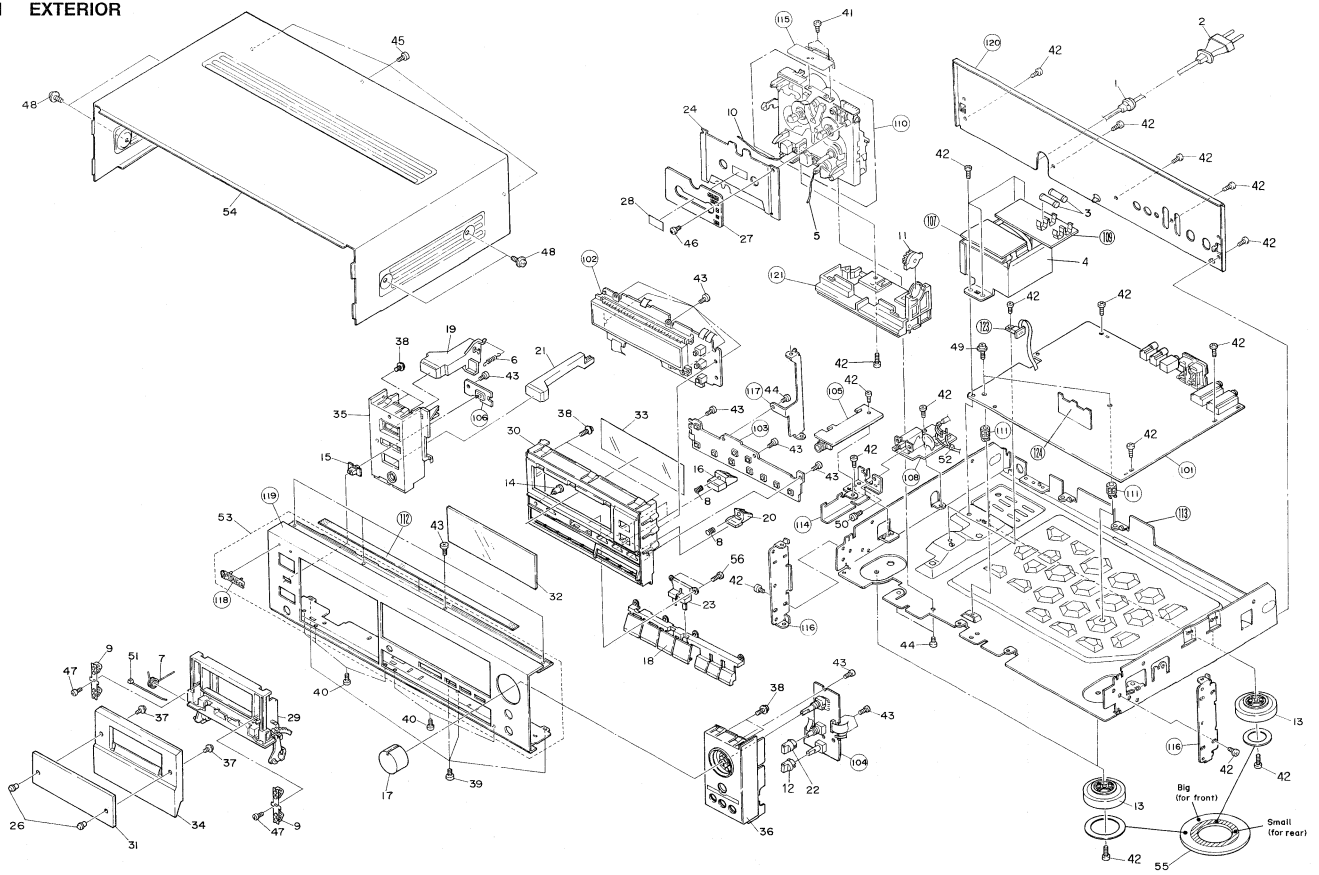

2.2 Parts List of Mechanism Unit

Mark	No.	Description	Parts No.
	1	Fixed core	RLA1130
	2	Plunger	RLA1132
	3	Head (R/P)	RPB1039
	4	Head (E)	RPB1040
	5	Push SW	RSG1018
	6	MTR reel BLK	RXM1029
	7	MTR main BLK	RXM1032
	8	Solenoid BLK	RXF1010
	9	Photo-transistor	SPI33534FG
	10	Main belt	REB1134
	11	Pinch roller ass'y	RXA1183
	12	F/W ass'y	RXA1346
	13	Washer	WA26D045D025
	14	Pan 2.6 x 6.4 ZN	RBA1075
	15	Washer	RBF-057
	16	Reel base BLK	RXA1184
	17	Idle BLK	RXA1248
	18	Reel base BLK	RXC-040
	19	Washer	WA21D070D013
	20	Azimuth SP	RBH1076
	21	Head base SP	RBL1003
	22	Slide SP	RBH1239
	23	Play arm	RNK1525
	24	Cam gear (3R)	RNK1566
	25	Pan TT 2.6 x 5 ZN	RBA1079
	26	Lever SP(L) (EJECT)	RBH1231
	27	SP cap(L) (EJECT)	RBH1234
	28	Spring (CASETTE)	RBK1031
	29	Lever (Color A)	RLA1133
	30	Detector lever (REC)	RNK1527
	31	Metal dector lever (L)	RNK1529
	32	Dector lever (P)	RNK1543
	33	Hook	RNK1160
	34	Screw	PBZ30P080FMC
	35	Screw	PCZ20P040FMC
	36	Screw	PMZ26P050FMC
	37	F lock screw	RBA1031
	38	Screw (7.7)	RBA1048
	39	Screw	RBA1078
	40	Washer	WA26D047D050
	41	Washer	YE15FUC
	101	Jumper (3P)	
	104	Connector (8P)	
	105	Connector (6P)	
	106	P. C. board	
	107	Chassis base BLK	
	108	Head base	
	109	Head spacer	
	110	Arm cap (L) (EJECT)	
	111	Lever (EJECT)	

2.2 MECHANISM UNIT

A

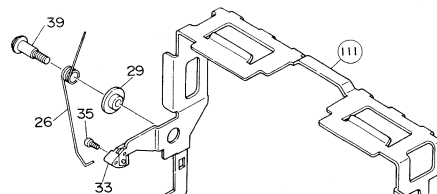

B

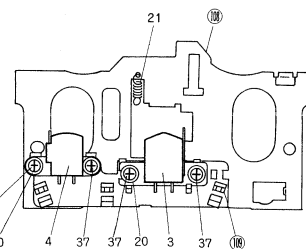

C

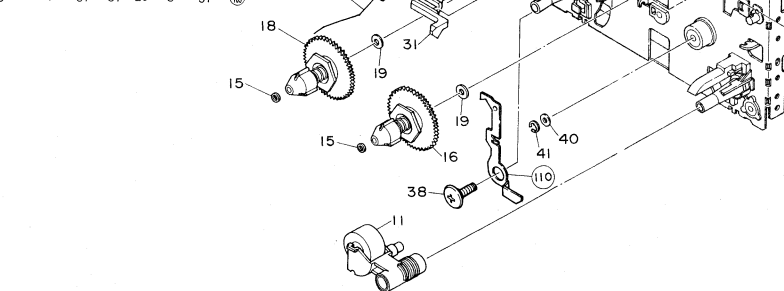

D

2.2 MECHANISM UNIT

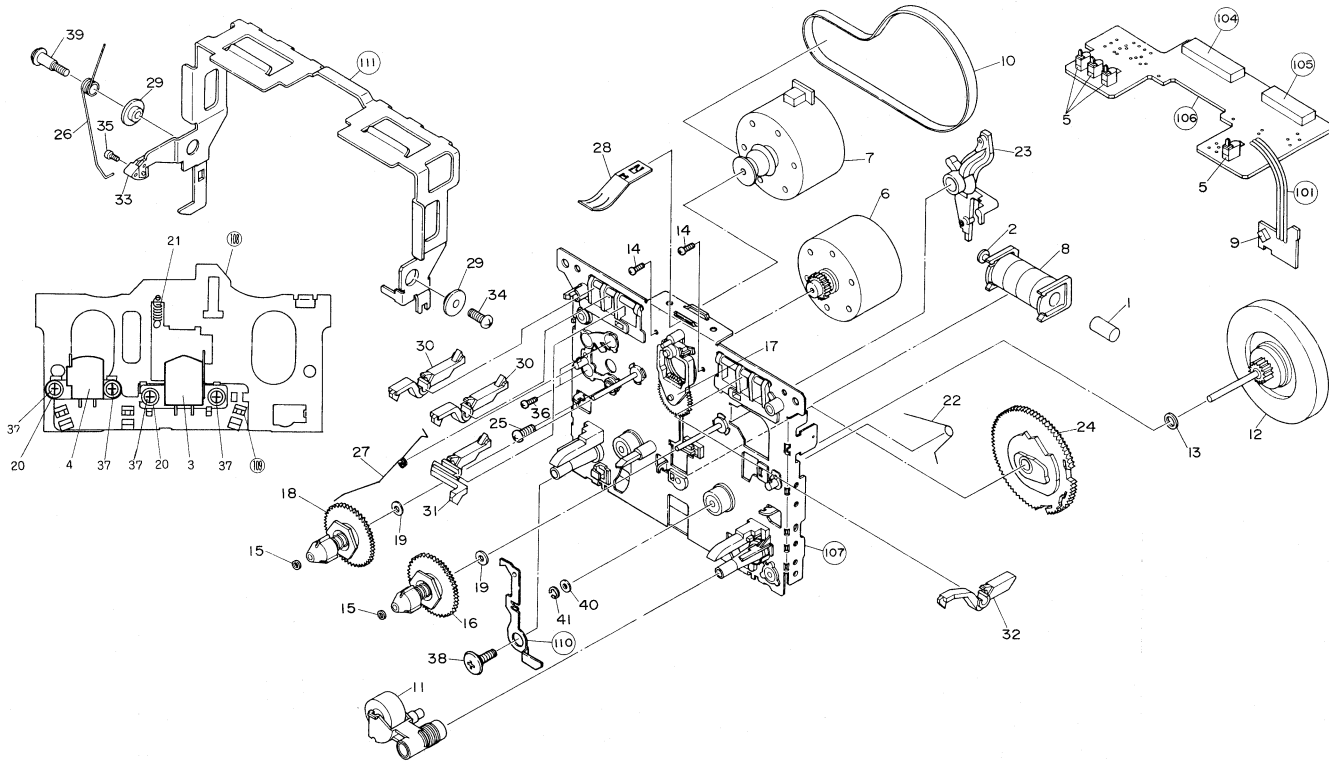

A

B

C

D

7

1

2

3

4

5

6

IC502 : BA6138

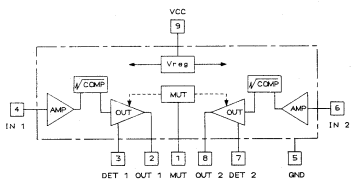

IC901 : BA6218

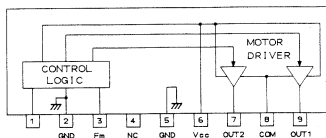

IC601 : MPC1297CA

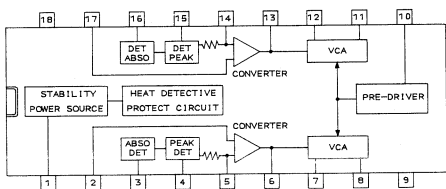

IC201 : CXA1330S

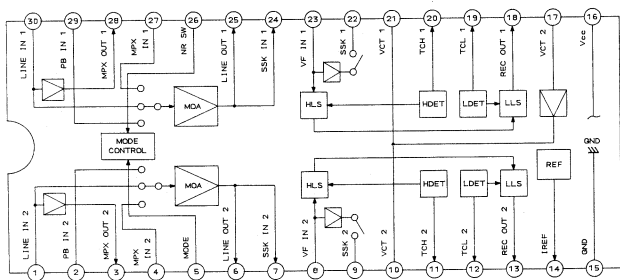

3. IC BLOCK DIAGRAM

IC301 : CXA1198AP-A

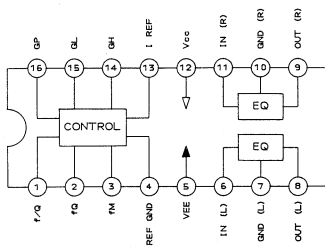

3. IC BLOCK DIAGRAM

IC301 : CXA1198AP-A

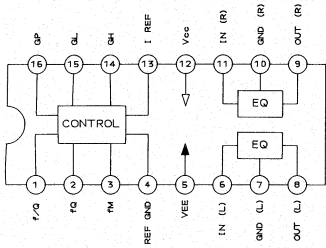

IC502 : BA6138

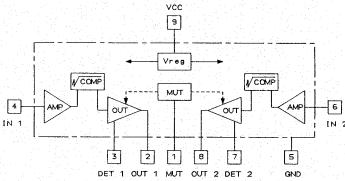

IC901 : BA6218

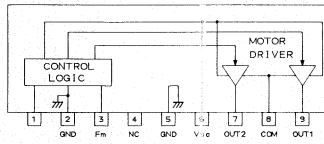

4. BLOCK DIAGRAM

IC601 : MPC1297CA

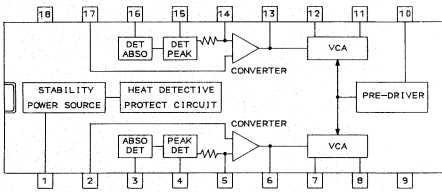

IC201 : CXA1330S

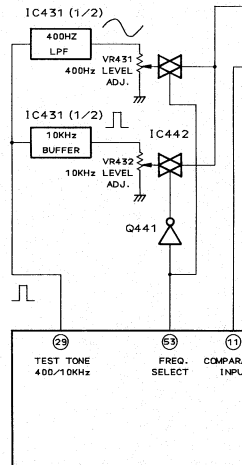
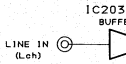
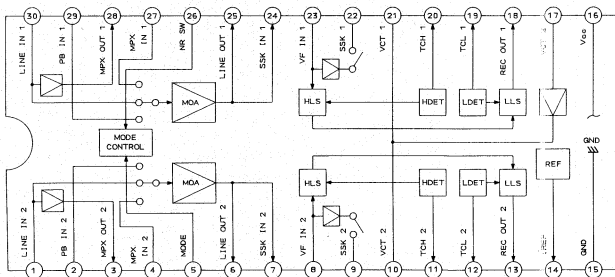

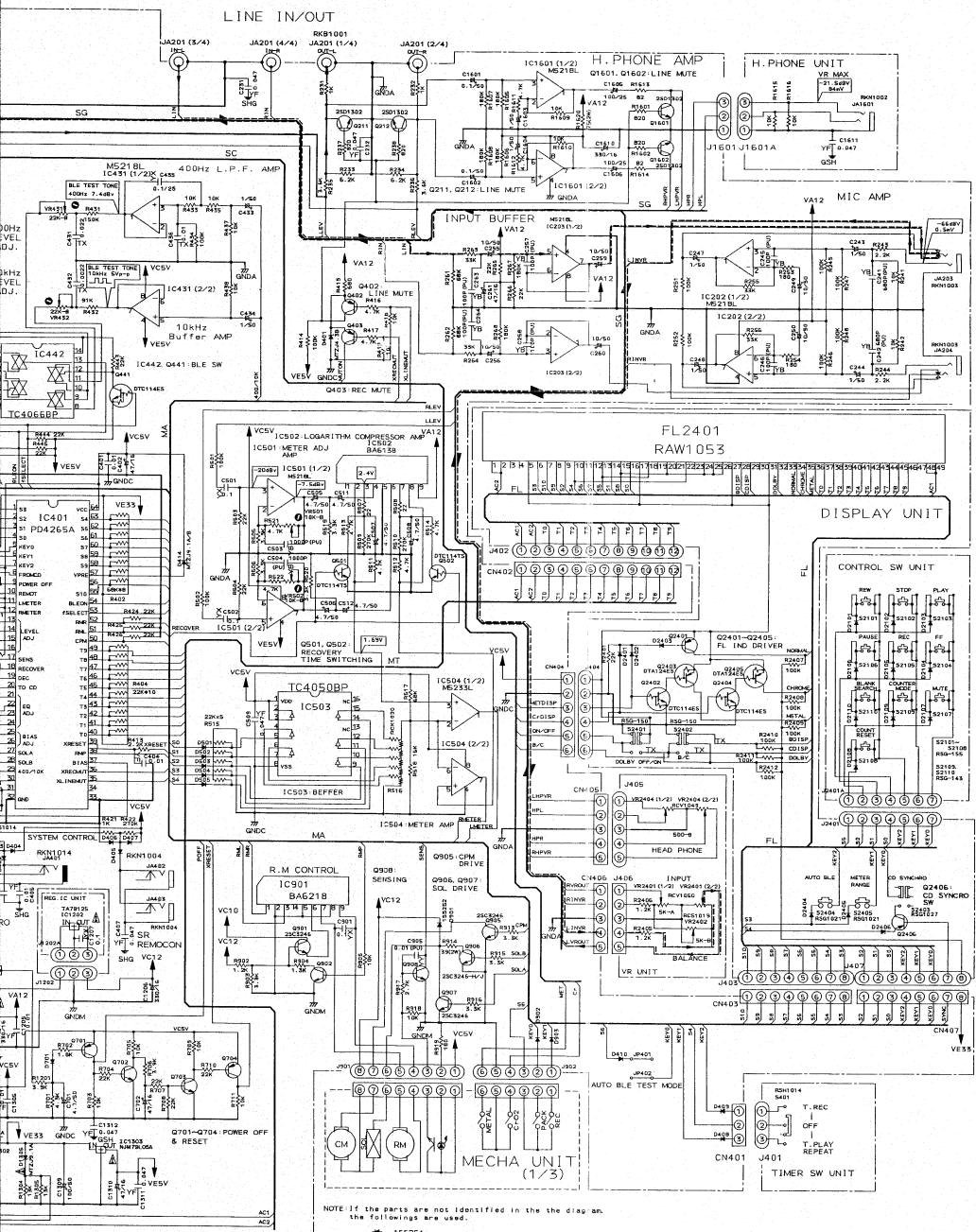

NOTE: IF THE PARTS ARE NOT IDENTIFIED IN THE DIAGRAM, THE FOLLOWINGS ARE USED.

- RES 155254
- RES 25C3511A
- RES 25A1309A

6. P.C. BOARDS CONNECTION DIAGRAM

- View from component side

A

HEM, HEWM,
HB type

B

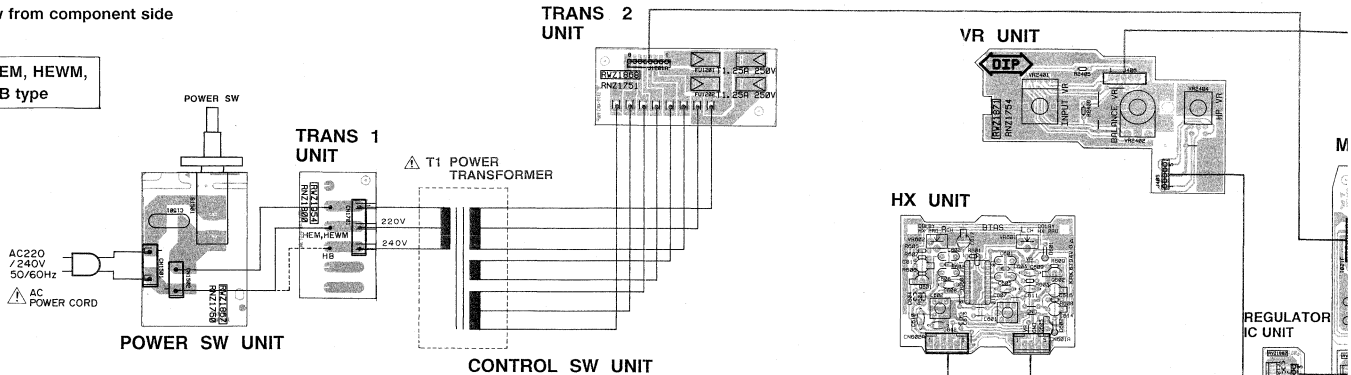

C

- 1. RESISTORS:**
Indicated in Ω , 1/4W, 1/6W, $\pm 5\%$ tolerance unless otherwise noted
K; kd, M; Md, (F); $\pm 1\%$; (G); $\pm 2\%$; (K); $\pm 10\%$; (M); $\pm 20\%$ tolerance.

- 2. CAPACITORS:**
Indicated in capacity (μ F) / voltage (V) unless otherwise noted μ ; pF.
Indication without voltage is 50V except electrolytic capacitor.

- 3. VOLTAGE CURRENT:**
□: DC voltage (V) at no input signal.

- 4. OTHERS:**
— PLAYBACK SIGNAL ROUTE
- - - - - RECORDING SIGNAL ROUTE
⊗: Adjusting point.
The Δ mark found on some component parts indicates the importance of the safety factor of the part. Therefore, when replacing, be sure to use parts of identical designation.
* marked capacitors and resistors have parts numbers.
This is the basic schematic diagram, but the actual circuit may vary due to improvements in design.

- ▶: Test point

- 5. SWITCHES (underline indicates switch position)**

- TIMER SW. UNIT**
S401: REC-OFF-PLAY/REPEAT
- POWER SW. UNIT**
S1501: POWER ON-OFF
- DISPLAY UNIT**
S2401: DOLBY NR ON-OFF
S2402: DOLBY NR B-C
S2403: CD SYNCHRO
S2404: AUTO BLE
S2405: METER RANGE
- CONTROL SW. UNIT**
S2101: REW
S2102: STOP
S2103: PLAY
S2104: FF
S2105: REC
S2106: PAUSE
S2107: MUTE
S2108: COUNT
 RESET
S2109: COUNTER
 MODE
S2110: BL ANK
 SEARCH

D

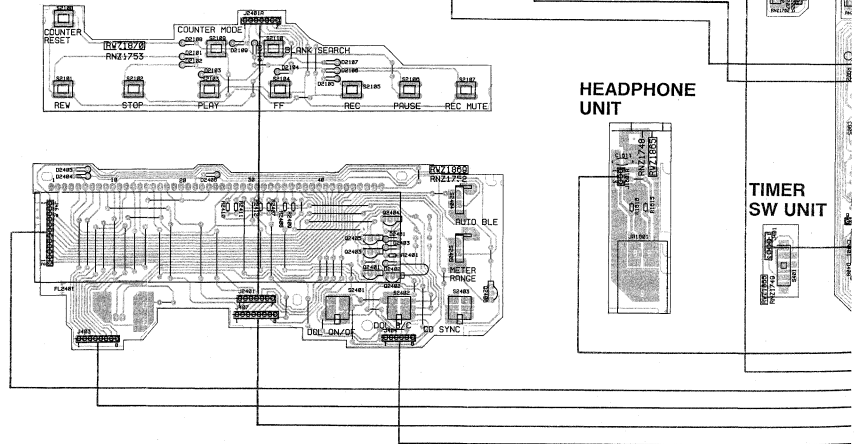

1

2

3

4

5

6

VR UNIT

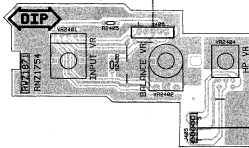

HX UNIT

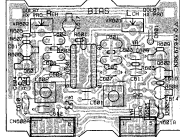

MAIN UNIT

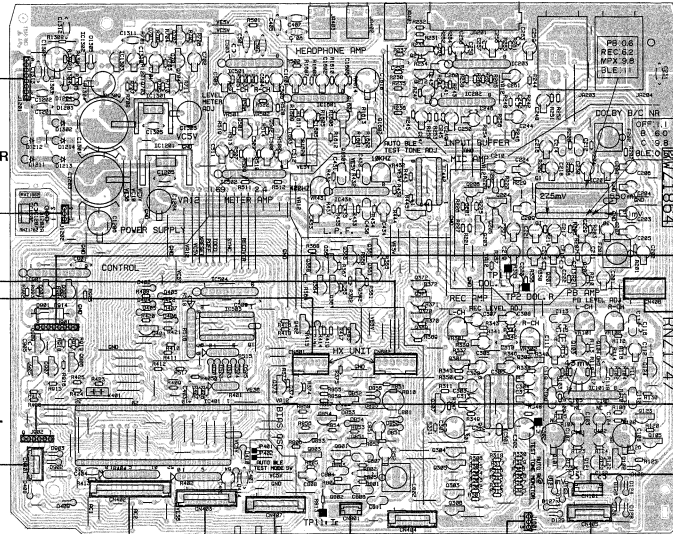

REGULATOR IC UNIT



HEADPHONE UNIT

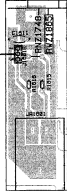

TIMER SW UNIT



0701		Q211
0702		IC203
IC1303	IC501	Q212
IC1302		
0703		
0704	IC1601	IC202
IC1301		

VR501		0501	
VR502		0502	
		Q1602	
		Q1601	IC442
VR432	IC1201	IC502	Q204
VR431		IC431	Q441

		IC201
		Q205
		Q203

		Q365	
		Q366	
		Q367	Q201
		Q368	Q202
		Q361	
		Q372	
		Q371	
		Q363	
		Q370	

VR101		Q369	
VR102			Q103
VR301			Q301
VR302			Q104
			Q124
			IC101
			Q123
			Q105
			Q101
			Q121
			Q122
			Q102
			Q303
			Q306

● View from soldering side

A

B

C

D

MECHANISM UNIT

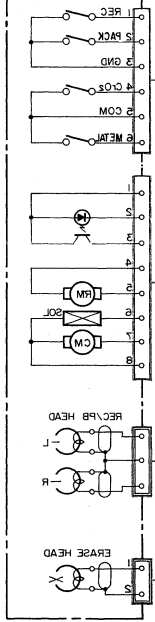

0306	0805	0805	0302
0305	0801	0801	0304
0304	0802	0802	0151
0303	0803	0803	0151
0302	0804	0804	0101
0301	0805	0805	0101
0300	0806	0806	0102
0299	0807	0807	0104
0298	0808	0808	0104
0297	0809	0809	0103
0296	0810	0810	0103
0295	0811	0811	0103
0294	0812	0812	0103
0293	0813	0813	0103
0292	0814	0814	0103
0291	0815	0815	0103
0290	0816	0816	0103
0289	0817	0817	0103
0288	0818	0818	0103
0287	0819	0819	0103
0286	0820	0820	0103
0285	0821	0821	0103
0284	0822	0822	0103
0283	0823	0823	0103
0282	0824	0824	0103
0281	0825	0825	0103
0280	0826	0826	0103
0279	0827	0827	0103
0278	0828	0828	0103
0277	0829	0829	0103
0276	0830	0830	0103
0275	0831	0831	0103
0274	0832	0832	0103
0273	0833	0833	0103
0272	0834	0834	0103
0271	0835	0835	0103
0270	0836	0836	0103
0269	0837	0837	0103
0268	0838	0838	0103
0267	0839	0839	0103
0266	0840	0840	0103
0265	0841	0841	0103
0264	0842	0842	0103
0263	0843	0843	0103
0262	0844	0844	0103
0261	0845	0845	0103
0260	0846	0846	0103
0259	0847	0847	0103
0258	0848	0848	0103
0257	0849	0849	0103
0256	0850	0850	0103
0255	0851	0851	0103
0254	0852	0852	0103
0253	0853	0853	0103
0252	0854	0854	0103
0251	0855	0855	0103
0250	0856	0856	0103
0249	0857	0857	0103
0248	0858	0858	0103
0247	0859	0859	0103
0246	0860	0860	0103
0245	0861	0861	0103
0244	0862	0862	0103
0243	0863	0863	0103
0242	0864	0864	0103
0241	0865	0865	0103
0240	0866	0866	0103
0239	0867	0867	0103
0238	0868	0868	0103
0237	0869	0869	0103
0236	0870	0870	0103
0235	0871	0871	0103
0234	0872	0872	0103
0233	0873	0873	0103
0232	0874	0874	0103
0231	0875	0875	0103
0230	0876	0876	0103
0229	0877	0877	0103
0228	0878	0878	0103
0227	0879	0879	0103
0226	0880	0880	0103
0225	0881	0881	0103
0224	0882	0882	0103
0223	0883	0883	0103
0222	0884	0884	0103
0221	0885	0885	0103
0220	0886	0886	0103
0219	0887	0887	0103
0218	0888	0888	0103
0217	0889	0889	0103
0216	0890	0890	0103
0215	0891	0891	0103
0214	0892	0892	0103
0213	0893	0893	0103
0212	0894	0894	0103
0211	0895	0895	0103
0210	0896	0896	0103
0209	0897	0897	0103
0208	0898	0898	0103
0207	0899	0899	0103
0206	0900	0900	0103
0205	0901	0901	0103
0204	0902	0902	0103
0203	0903	0903	0103
0202	0904	0904	0103
0201	0905	0905	0103
0200	0906	0906	0103
0199	0907	0907	0103
0198	0908	0908	0103
0197	0909	0909	0103
0196	0910	0910	0103
0195	0911	0911	0103
0194	0912	0912	0103
0193	0913	0913	0103
0192	0914	0914	0103
0191	0915	0915	0103
0190	0916	0916	0103
0189	0917	0917	0103
0188	0918	0918	0103
0187	0919	0919	0103
0186	0920	0920	0103
0185	0921	0921	0103
0184	0922	0922	0103
0183	0923	0923	0103
0182	0924	0924	0103
0181	0925	0925	0103
0180	0926	0926	0103
0179	0927	0927	0103
0178	0928	0928	0103
0177	0929	0929	0103
0176	0930	0930	0103
0175	0931	0931	0103
0174	0932	0932	0103
0173	0933	0933	0103
0172	0934	0934	0103
0171	0935	0935	0103
0170	0936	0936	0103
0169	0937	0937	0103
0168	0938	0938	0103
0167	0939	0939	0103
0166	0940	0940	0103
0165	0941	0941	0103
0164	0942	0942	0103
0163	0943	0943	0103
0162	0944	0944	0103
0161	0945	0945	0103
0160	0946	0946	0103
0159	0947	0947	0103
0158	0948	0948	0103
0157	0949	0949	0103
0156	0950	0950	0103
0155	0951	0951	0103
0154	0952	0952	0103
0153	0953	0953	0103
0152	0954	0954	0103
0151	0955	0955	0103
0150	0956	0956	0103
0149	0957	0957	0103
0148	0958	0958	0103
0147	0959	0959	0103
0146	0960	0960	0103
0145	0961	0961	0103
0144	0962	0962	0103
0143	0963	0963	0103
0142	0964	0964	0103
0141	0965	0965	0103
0140	0966	0966	0103
0139	0967	0967	0103
0138	0968	0968	0103
0137	0969	0969	0103
0136	0970	0970	0103
0135	0971	0971	0103
0134	0972	0972	0103
0133	0973	0973	0103
0132	0974	0974	0103
0131	0975	0975	0103
0130	0976	0976	0103
0129	0977	0977	0103
0128	0978	0978	0103
0127	0979	0979	0103
0126	0980	0980	0103
0125	0981	0981	0103
0124	0982	0982	0103
0123	0983	0983	0103
0122	0984	0984	0103
0121	0985	0985	0103
0120	0986	0986	0103
0119	0987	0987	0103
0118	0988	0988	0103
0117	0989	0989	0103
0116	0990	0990	0103
0115	0991	0991	0103
0114	0992	0992	0103
0113	0993	0993	0103
0112	0994	0994	0103
0111	0995	0995	0103
0110	0996	0996	0103
0109	0997	0997	0103
0108	0998	0998	0103
0107	0999	0999	0103
0106	1000	1000	0103
0105	1001	1001	0103
0104	1002	1002	0103
0103	1003	1003	0103
0102	1004	1004	0103
0101	1005	1005	0103
0100	1006	1006	0103
0099	1007	1007	0103
0098	1008	1008	0103
0097	1009	1009	0103
0096	1010	1010	0103
0095	1011	1011	0103
0094	1012	1012	0103
0093	1013	1013	0103
0092	1014	1014	0103
0091	1015	1015	0103
0090	1016	1016	0103
0089	1017	1017	0103
0088	1018	1018	0103
0087	1019	1019	0103
0086	1020	1020	0103
0085	1021	1021	0103
0084	1022	1022	0103
0083	1023	1023	0103
0082	1024	1024	0103
0081	1025	1025	0103
0080	1026	1026	0103
0079	1027	1027	0103
0078	1028	1028	0103
0077	1029	1029	0103
0076	1030	1030	0103
0075	1031	1031	0103
0074	1032	1032	0103
0073	1033	1033	0103
0072	1034	1034	0103
0071	1035	1035	0103
0070	1036	1036	0103
0069	1037	1037	0103
0068	1038	1038	0103
0067	1039	1039	0103
0066	1040	1040	0103
0065	1041	1041	0103

7. P.C.B's PARTS LIST

NOTES:

- Parts without part number cannot be supplied.
- Parts marked by "⊗" are not always kept in stock. Their delivery time may be longer than usual or they may be unavailable.
- The Δ mark found on some component parts indicates the importance of the safety factor of the part. Therefore, when replacing, be sure to use parts of identical designation.
- When ordering resistors, first convert resistance values into code form as shown in the following examples.

Ex. 1 When there are 2 effective digits (any digit apart from 0), such as 560 ohm and 47k ohm (tolerance is shown by J = 5%, and K = 10%).

560 Ω	56 $\times 10^1$	561.....	RD14PS	\square \square \square J
47k Ω	47 $\times 10^3$	473.....	RD14PS	\square \square \square J
0.5 Ω	0R5.....		RN2H	\square \square \square K
1 Ω	010.....		RS1P	\square \square \square K

Ex. 2 When there are 3 effective digits (such as in high precision metal film resistors).

5.62k Ω	562 $\times 10^1$	5621.....	RN14SR	\square \square \square F
----------------	-------------------	-----------	--------	---------------------------------

Mark	No.	Description	Parts No.	Mark	No.	Description	Parts No.
HX UNIT				POWER SW. UNIT			
SEMICONDUCTORS				CAPACITOR			
	IC901	DOLBY HX PRO IC	UPC1297CA	Δ C1501		ELECTR. CAPACITOR (0.01 μ F)	RCG-009
	Q601, Q602	TRANSISTOR	2SA1309A	SWITCH			
	Q603	TRANSISTOR	DTC124ES	Δ S1501		POWER SWITCH	RSA-063
	D601, D602	DIODE	1SS254	DISPLAY UNIT			
COILS				SEMICONDUCTORS			
	L601, L602	COIL	RTD1046	Q2401		TRANSISTOR	2SA1309A
CAPACITORS				Q2402		TRANSISTOR	DTC114ES
	C601, C602	AUDIO FILM CAPACITOR	CFTXA103J50	Q2403		TRANSISTOR	DTA124ES
	C603, C604	AXIAL CERAMIC CAPACITOR	CKPUYB821K50	Q2404		TRANSISTOR	DTC114ES
	C605, C606	AUDIO FILM CAPACITOR	CFTXA223J50	Q2405		TRANSISTOR	DTA124ES
	C607, C608	CERAMIC CAPACITOR	CGCYX473K25	Q2406		TRANSISTOR	2SA1309A
	C609, C610	CERAMIC CAPACITOR	CCCCL101K500	D2401-D2406		DIODE	1SS254
	C611, C612	CERAMIC CAPACITOR (430P, 500V)	RCG1005	RESISTORS			
	C613	AXIAL CERAMIC CAPACITOR	CKPUYB101K50	OTHER RESISTORS			
	C614	ELECTR. CAPACITOR	CEASR10M50	RD1/6PM \square \square \square \square \square \square			
	C615	ELECTR. CAPACITOR	CEAS100M50	SWITCHES			
	C616	ELECTR. CAPACITOR	CEAS4R7M50	S2401, S2402		PUSH SWITCH (DOLBY NR ON-OFF, DOLBY NR B-C)	RSG-150
	C617	ELECTR. CAPACITOR	CEAS100M50	S2403		PUSH SWITCH (CD SYNCHRO)	RSG1027
RESISTORS				S2404, S2405		TACT SWITCH (AUTO BLE, METER RANGE)	RSG1021
	VR601, VR602	SEMI-FIXED (22KB)	VRTB6HS223	OTHER			
	OTHER RESISTORS		RD1/6PM \square \square \square \square \square \square	V2401		FL TUBE	RAW1053
HEADPHONE UNIT				CONTROL SW. UNIT			
CAPACITOR				SEMICONDUCTORS			
	C1611	CERAMIC CAPACITOR	CKCYF473Z50	D2101-D2110		DIODE	1SS254
RESISTORS				SWITCHES			
	OTHER RESISTORS		RD1/6PM \square \square \square \square \square \square	S2101-S2108		TACT SWITCH (REW, STOP, PLAY, FF, REC, PAUSE, MUTE, COUNT/RESET)	RSG-155
OTHER				S2109, S2110		TACT SWITCH (COUNTER/MODE, BLANK/SEARCH)	RSG-143
TIMER SW. UNIT				SWITCH			
	S401	SLIDE SWITCH (1-3) (REC-OFF-PLAY/REPEAT)	RSH1014				

Mark No.	Description	Parts No.
VOLUME UNIT		
RESISTORS		
VR2401 (5KA)		RCV1050
VR2402 (5KB)		RCS1019
VR2404 (500ΩB)		RCV1049
OTHER RESISTORS		
		RD16PM□□□□

REGULATOR IC UNIT

Mark No.	Description	Parts No.
SEMICONDUCTORS		
IC1202 REGULATOR IC		TA7812S
CAPACITOR		
△ C1207 AXIAL CERAMIC CAPACITOR		CFTXA104J50

TRANSFORMER 1 UNIT

There is no supply part in this UNIT.

TRANSFORMER 2 UNIT

There is no supply part in this UNIT.

MAIN UNIT

Mark No.	Description	Parts No.
SEMICONDUCTORS		
IC101 OP-AMP IC		M5220L
IC201 DOLBY-B/C IC		CXA1330S
IC202, IC203 OP-AMP IC		M5218L
IC301 REC-EQ AMP IC		CXA1198AP-A
IC401 U-COM IC		PD4265A
IC431 OP-AMP IC		M5218L
IC442 LOGIC IC		TC4066BP
IC501 OP-AMP IC		M5218L
IC502 LOG-COMPRESS-AMP IC		BA6138
IC503 CMOS LOGIC IC		TC4050BP
IC504 DUAL-COMPARATER IC		M5233L
IC901 IC		BA6218
△ IC1201 REGULATOR IC		NJM7812FA
△ IC1301 REGULATOR IC		NJM78M05FA
△ IC1302 REGULATOR IC		NJM79L12A
△ IC1303 REGULATOR IC		NJM79L05A
IC1601 OP-AMP IC		M5218L
Q101, Q102 TRANSISTOR		Z5C3311A
Q103, Q104 TRANSISTOR		DTC114ES
Q105 TRANSISTOR		DTC124ES
Q121, Q122 N-FET		2SK373
Q123 TRANSISTOR		DTA124ES
Q124 TRANSISTOR		DTC124ES
Q201, Q202 TRANSISTOR		2SD1302
Q203 TRANSISTOR		DTC114TS
Q204 TRANSISTOR		DTA124ES
Q205 TRANSISTOR		DTC114TS
Q206 TRANSISTOR		DTC124ES
Q211, Q212 TRANSISTOR		2SD1302
Q301, Q302 TRANSISTOR		Z5C3311A
Q303-Q307 TRANSISTOR		DTC114ES
Q361-Q374 TRANSISTOR		DTC114ES
Q401 TRANSISTOR		DTC114ES
Q402, Q403 TRANSISTOR		Z5A1309A
Q441 TRANSISTOR		DTC114ES

Mark No.	Description	Parts No.
Q501, Q502 TRANSISTOR		DTC114TS
Q701 TRANSISTOR		Z5A1309A
Q702, Q703 TRANSISTOR		Z5C3311A
Q704 TRANSISTOR		Z5A1309A
Q801-Q803 TRANSISTOR		Z5C3243
Q851, Q852 TRANSISTOR		Z5A1283
Q853, Q854 TRANSISTOR		Z5C3311A
Q901 TRANSISTOR		Z5C3246
Q902 TRANSISTOR		Z5C3311A
Q905-Q907 TRANSISTOR		Z5C3246
Q808 TRANSISTOR		Z5C3311A
Q1302 TRANSISTOR		Z5A1283
Q1601, Q1602 TRANSISTOR		Z5D1302
D121-D130 DIODE		1SS254
D201, D202 DIODE		1SS254
D401 ZENER DIODE		MTZJ4.3B
D402-D410 DIODE		1SS254
D414 ZENER DIODE		MTZJ9.1A
D501-D505 DIODE		1SS254
D701 DIODE		1SS254
D851 DIODE		1SS254
D852 DIODE		1SS252
D853-D856 DIODE		1SS254
D901 DIODE		1SS252
D902, D903 DIODE		1SS254
△ D1203, D1204 DIODE		1SS254
△ D1211-D1214 DIODE		1SR35-100A
△ D1302 DIODE		1SR35-100A
△ D1303 DIODE		1SS252
△ D1304 ZENER DIODE		MTZJ20A
△ D1305 ZENER DIODE		MTZJ9.1A

COILS AND FILTERS

Mark No.	Description	Parts No.
L301, L302 COIL		RTF1102
L801 COIL		LRA121K
L802 COIL		RTD1054
F201, F202 MPX FILTER		RTF1062

CAPACITORS

Mark No.	Description	Parts No.
C101, C102 PP CAPACITOR		COSA821J50
C103, C104 ELECT. CAPACITOR		CEANL100M16
C105, C106 AXIAL CERAMIC CAPACITOR		CKPUYB101K50
C107, C108 ELECT. CAPACITOR		CEANL101M10
C109, C110 AUDIO FILM CAPACITOR		CFTXA223J50
C111, C112 ELECT. CAPACITOR		CEAS100M50
C113, C114 AUDIO FILM CAPACITOR		CFTXA223J50
C115, C116 AXIAL CERAMIC CAPACITOR		CKPUYB102K90
C117 ELECT. CAPACITOR		CEAS101M25
C118 CERAMIC CAPACITOR		CKCYF103Z50
C119 ELECT. CAPACITOR		CEAS470M16
C121, C122 AXIAL CERAMIC CAPACITOR		CGPUSL100J50
C201-C204 ELECT. CAPACITOR		CEAS010M50
C205-C208 ELECT. CAPACITOR		CEAS100M50
C209, C210 ELECT. CAPACITOR		CEAS4R7M50
C211-C214 AUDIO FILM CAPACITOR		CFTXA222J50
C215, C216 ELECT. CAPACITOR		CEASR22M50
C217, C218 ELECT. CAPACITOR		CEASR33M50
C219, C220 ELECT. CAPACITOR		CEAS330M16
C221 ELECT. CAPACITOR		CEAS100M50

8. ADJUSTMENTS

8.1 MECHANICAL ADJUSTMENT

1. Tape speed adjustment

Mode	Test tape	Adjustment position	Specification rating (playback frequency)
PLAY	Play the STD-301 tape (3kHz)	Variable resistor control	3000Hz \pm 5Hz

Note: Adjust after one minute of playback.

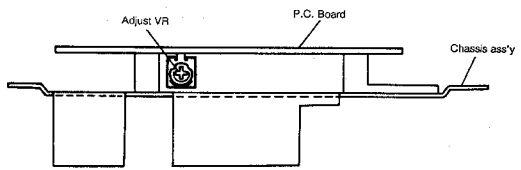

Mechanism unit diagram, top view

Fig. 8-1

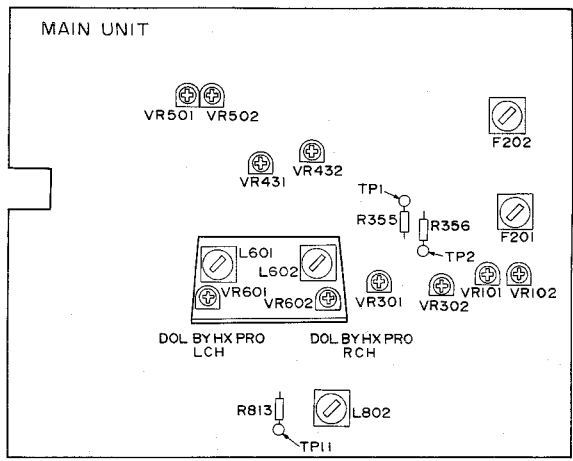

Fig. 8-2

8.2 ELECTRICAL ADJUSTMENTS

Adjustment Conditions

1. The mechanical adjustments must be completed first.
2. The head must be cleaned and demagnetized.
3. Turn power on allow the deck to warm up for at least a few minutes before commencing any electrical adjustments.
4. The reference signal is $0dBv = 1Vrms$.
5. Connect a 50 kilo-ohm (or between 47 to 52 kilo-ohm) load resistance to the OUTPUT terminals.
6. Unless otherwise specified, the switches listed below are left in the positions indicated.

DOLBY NR : OFF
 TAPE SELECTOR : NORM

Test Tapes

- STD-331B : Playback adjustments
 (See Fig. 8-3)
- STD-630 : NORMAL blank tape
- STD-620 : CrO₂ blank tape
- STD-610 : METAL blank tape

List of Adjustments

Playback sections

1. Head azimuth adjustment.
2. Playback level adjustment.

Recording sections

1. Bias oscillator adjustment.
2. Recording bias adjustment.
3. Recording level adjustment.
4. Auto BLE and level meter adjustment.

NOTE: This unit has an automatic tape selection feature.

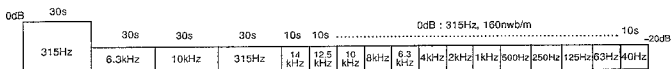

Fig. 8-3 Constants of the test tape STD-331B

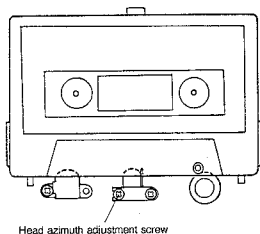

Fig. 8-4 Head azimuth adjustment

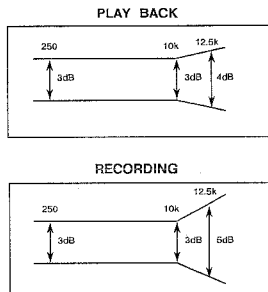

Fig. 8-5 Allowable playback frequency response zone

PLAYBACK SECTION

1. Head Azimuth Adjustment

- Turn VR101, VR102 to mechanical center positions.

No.	Mode	Input signal & test tape	Adjustment location	Measuring location	Adjustment value	Remarks	
1.	PLAY	Play the 10kHz/20dB section of STD-331B test tape.	Head azimuth adjustment screw. (See Fig. 8.4)	LINE OUT	Maximum playback signal level.		
2.	STOP	Lock the screw with screw lock after completing adjustment.					

2. Playback Level Adjustment

- This adjustment determines the DOLBY NR level, and must be performed with great care.

No.	Mode	Input signal & test tape	Adjustment location	Measuring location	Adjustment value	Remarks
1.	PLAY	Play the 315 Hz/0 dB section of STD-331B test tape.	Deck I VR101 (Lch) VR102 (Rch)	TP1. DOL L (Lch) TP2. DOL R (Rch)	-10.7 dBv	

RECORDING SECTION

1. Bias Oscillator Adjustment

- Adjust the bias oscillator with checks set to recording mode simultaneously. (Double R/P only)

No.	Mode	Input signal & test tape	Adjustment location	Measuring location	Adjustment value	Remarks
1.	REC	Load the STD-610 test tape with no input signal.	Deck I L802	TP. 11	105 kHz \pm 0.3 kHz	

2. Recording Bias Adjustment

- After the adjustment, caution should be exercised so as not to become under bias by checking the distortion rate.

No.	Mode	Input signal & test tape	Adjustment location	Measuring location	Adjustment value	Remarks	
1.	STOP	Set the TAPE SELECTOR switch to the NORM position.					
2.	REC	Record the 315 Hz and 6.3 kHz signals at -20 dBv input level and playback.	Deck I VR601 (Lch) VR602 (Rch)	LINE OUT	Repeatedly record, playback and adjust so that the playback level of 6.3 kHz signal becomes +0.5 dB \pm 0.5 dB when compared with the 315 Hz signal.		

3. Recording Level Adjustment

No.	Mode	Input signal & test tape	Adjustment location	Measuring location	Adjustment value	Remarks
1.	STOP	Set the TAPE SELECTOR switch to the NORM position.				
2.	REC PAUSE	Apply a 315Hz/0dBv signal to the line input terminals, load the STD-630 test tape.	Rec Level control volume	TP. 1 DOL. L (Lch) TP. 2 DOL. R (Rch)	-11.2 dBv	
3.	STOP	Set the DOLBY NR switch to the ON position. (DOLBY B)				
4.	REC/PLAY	Record the above signal onto the STD-620 test tape, and playback.	Deck 1	VR301 (Lch) VR302 (Rch)	TP. 1 DOL. L (Lch) TP. 2 DOL. R (Rch)	Repeatedly record, playback and adjust so that the playback signal level becomes -11.2dB.
5.	STOP	Set the TAPE SELECTOR switch to the CrO ₂ position.				
6.	REC/PLAY	Record the above signal onto the STD-620 test tape, and playback.	Check		TP. 1 DOL. L (Lch) TP. 2 DOL. R (Rch)	-11.2 dBv ± 1.5dB
7.	STOP	Set the TAPE SELECTOR switch to the METAL position.				
8.	REC/PLAY	Record the above signal onto the STD-610 test tape, and playback.	Check		TP. 1 DOL. L (Lch) TP. 2 DOL. R (Rch)	-11.2 dBv ± 1.5dB

4. Auto BLE and Level Meter adjustment

No.	Mode	Input signal & test tape	Adjustment location	Measuring location	Adjustment value	Remarks
1	Select test mode by short-circuiting between JP-401 and JP-402. (Instantly)					
2	REW	(TEST 1: 400 Hz)	VR431	LINE OUT (Lch)	-19.5 dBV	*NOTE
			VR501	LEVEL METER	Adjust so that the segment of -10dB will blink.	
			VR431	LINE OUT (Rch)	-19.5 dBV	
			VR502	LEVEL METER	Adjust so that the segment of -10dB will blink.	
3	STOP	(TEST 2: 10 kHz)	VR432	LEVEL METER	Adjust so that the segment of -10dB of channel R will blink.	

***NOTE**

- Instantly shorted between jp401 and 402, it returns to test mode.
- To clear the test mode, push the AUTO BLE switch, or turn the power OFF.
- Adjustment of No. 2 should proceed in turns of above to down items.

● ANODE CONNECTION

	10G	9G	8G	7G	6G	5G	4G	3G	2G	1G
S1	a	a	a	a	a		B1	B1	B1	B1
S2	b	b	b	b	b	REC	B2	B2	B2	B2
S3	c	c	c	c	c	▶	B3	B3	B3	B3
S4	d	d	d	d	d	◀▶	B4	B4	B4	B4
S5	e	e	e	e	e	▶▶	TIME	e	e	B5
S6	f	f	f	f	f	CD	f	f	f	B6
S7	g	g	g	g	g	◆ DECK	g	g	g	B7
S8	h	h	h	h	h	SYNCHRO	h	h	h	B8
S9	i	i	i	i	i	HOLD	i	i	i	BLANK SEARCH
S10	-	-	j	-	j	dB - ∞ (UP)	-20 -15	-10 -7	-30	+1+3 \square +6+8
S11	-	col	k	-	-	dB - ∞ (DOWN)	-3 -2	-1 -0	+1+3 \square	+6+8+10+12
S12	-	-	-	-	-	-	•••••	•••••	•••••	•••••
S13	-	-	-	-	-	m	-	-	-	-
S14	-	-	-	-	-	-	BIAS	-	-	-
S15	-	-	-	-	-	-	O	-	-	-
S16	-	-	-	-	-	-	-	LEVEL	-	-
S17	-	-	-	-	-	-	-	q	-	-
S18	-	-	-	-	-	-	-	-	EQ	-
S19	-	-	-	-	-	-	-	-	s	-
S20	-	-	-	-	-	-	NORM	-	-	-
S21	-	-	-	-	-	-	-	CrO ₂	-	-
S22	-	-	-	-	-	-	-	-	METAL	-
S23	-	-	-	-	-	-	-	-	-	DOLBY NR ▶
S24	-	-	-	-	-	-	-	-	-	B
S25	-	-	-	-	-	-	-	-	-	C
S26	-	-	-	-	-	-	-	-	-	S
S27	-	-	-	-	-	-	-	-	-	HX PRO
S28	-	-	-	-	-	-	-	-	-	FILTER
S29	-	-	-	-	-	-	-	-	S29	-
S30	-	-	-	-	-	-	-	-	S30	-
S31	-	-	-	-	-	-	-	-	S31	-

10. FOR CT-447/HB AND CT-447-S/HEWM TYPES

NOTES:

- Parts without part number cannot be supplied.
- The Δ mark found on some component parts indicates the importance of the safety factor of the part. Therefore, when replacing, be sure to use parts of identical designation.
- Parts marked by "⊗" are not always kept in stock. Their delivery time may be longer than usual or they may be unavailable.

• Contrast of Miscellaneous Parts

The CT-447/HB and CT-447-S/HEWM types are the same as CT-447/HEM type with the exception of the following sections.

Mark	Symbol & Description	Parts No.			Remarks
		CT-447HEM	CT-447HB	CT-447-S HEWM	
	Knob A (SLIDE SW)	RAC-668	RAC-668	RAC1219	
	Knob (CD SYNCHRO, DOLBY ON/OFF, B/C TYPE)	RAC1230	RAC1230	RAC1308	
	Knob (TACT)	RAC1349	RAC1349	RAC1347	
	Knob (EJECT)	RAC1361	RAC1361	RAC1494	
	Knob (OPERATION)	RAC1362	RAC1362	RAC1495	
	Knob (VR)	RAC1363	RAC1363	RAC1496	
	Button (POWER)	RAC1364	RAC1364	RAC1497	
	Knob (REC BALANCE)	RAC1366	RAC1366	RAC1498	
	Knob (PHONES LEVEL)	RAC1416	RAC1416	RAC1499	
	Door panel	RAH1678	RAH1678	RAH1679	
	Mold (EJECT)	RNK1313	RNK1313	RNK1314	
	VR Escutcheon	RNK1315	RNK1315	RNK1316	
	Operating instructions (Dutch/Swedish/Spanish/Portuguese/French/German/Italian)	RRD1077	-----	RRD1077	
	Packing case	RHG1197	RHG1197	RHG1198	
	Bonnet	RXX1292	RXX1292	RXX1295	
	Front panel ass'y	RXX1293	RXX1293	RXX1294	
Δ	AC power cord	PDG1003	PDG1004	PDG1003	
	Button panel	RAH1680	RAH1680	RAH1681	

11. PANEL FACILITIES

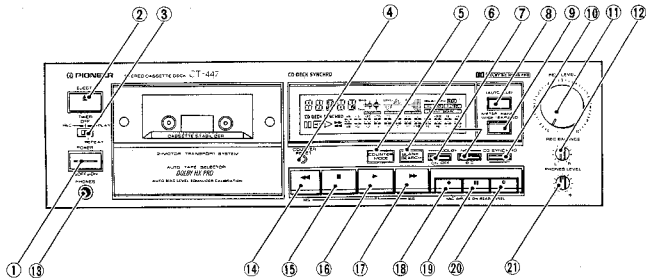

① POWER switch (■ OFF/ ■ ON)

② EJECT button (▲)

Press to open the cassette door after you have pressed stop button (■) and the tape has stopped.

NOTE:

If the power is turned off while the tape is moving, the cassette door may remain locked. In this case, turn the power on before pressing the EJECT button.

③ TIMER mode selector

OFF:

Normally, be sure to leave the switch in this position.

REC:

For timer recording.

PLAY/REPEAT:

For timer playback or for repeat playback.

- Recording or playback may suddenly start when turning the power on with this switch in the REC or PLAY position.

④ Tape/Time COUNTER RESET button

Press this button to zero the tape/time counter. Resets the tape/time counter reading to "0000".

⑤ COUNTER MODE button

Used to select the tape/time counter display mode. Each time this button is pressed, one of the following two modes is set in sequence.

⑥ BLANK SEARCH button

To find unrecorded portions on the tape.

⑦ DOLBY* NR switches

Set these switches to B or C for recording with the built-in Dolby Noise Reduction Systems and for playback of tapes which have been recorded using the Dolby Noise Reduction Systems. To play other tapes, set DOLBY NR switch to OFF. When DOLBY NR switch is set to ON, the MPX filter function operates in synchronization with the Dolby Noise Reduction System. The operation of this filter may cause some high frequencies to be muted when the Dolby NR system is used for recording of FM broadcasts from some tuners.

- Dolby noise reduction and HX Pro headroom extension manufactured under license from Dolby Laboratories Licensing Corporation. HX Pro originated by Bang & Olufsen.
- "DOLBY", the double-D symbol  and "HX PRO" are trademarks of Dolby Laboratories Licensing Corporation.

NOTE:

When playing back Dolby NR-encoded tapes, always set this switch to the same position (B or C) used for recording.

⑧ AUTO BLE button

This button allows to automatically set optimum recording bias, level and equalizer for the cassette tape. To use AUTO BLE, set the cassette tape and press this button.

⑨ METER RANGE WIDE/EXPAND button

Switches the display of the level meter range to WIDE/EXPAND.

⑩ CD SYNCHRO button

This button is used to carry out CD-Deck synchro recording from a CD player.

⑪ REC LEVEL control

12 REC BALANCE control

To balance the recording level between left (L) and right (R) channels.

13 PHONES jack**14 Rewind button (◀◀)**

To rewind the tape in the direction of the arrows. When this button is pressed during playback of a selection, the same selection will be played again. If pressed in the blank between two selections, the selection before the current tape position will be played. The unit will skip one selection in reverse direction for each time the (◀◀) button is pressed.

15 Stop button (■)

To stop all operations.

16 Playback button (▶)

To playback the front side of the tape, that is the side whose label is visible.

17 Fast forward button (▶▶)

To fast-forward the tape in the direction of the arrows. When pressed during playback, the unit will skip one selection in forward direction for each time the (▶▶) button is pressed.

18 Recording button (●)

When the recording (●) button is pressed, the unit is set to recording standby mode.

Press the pause (||) button or playback (▶) button when ready to record.

The unit will not enter the recording standby mode if loaded with a cassette with broken erasure prevention tabs.

19 Pause button (||)

To stop tape transport momentarily during recording or playback. To resume operation press it again. This can also be done by pressing the playback (▶) button. This button does not work during fast-forward and rewind.

20 Recording mute button (○)

Press this button during recording to create a blank portion of approx. 4 seconds on the tape. The unit will then enter the recording standby mode.

To make a blank space longer than 4 seconds, the button can be held depressed for the desired duration. Upon releasing the button, the unit will enter the recording standby mode.

21 PHONES LEVEL control

12. SPECIFICATIONS

System	4 track, 2-channel stereo
Heads	"Hard Permalloy" recording/playback head × 1 "Double gap ferrite" erasing head × 1
Motor	DC servo capstan motor × 1 DC reel motor × 1
Wow and Flutter	No more than ±0.14% (DIN)
Fast winding Time	Approximately 90 seconds (C-60 tape)
Frequency Response (±6 dB)	
- 20 dB recording:	
Normal tape	20 to 17,000 Hz
Chrome tape	20 to 17,000 Hz
Metal tape	20 to 19,000 Hz
Signal-to-Noise Ratio	
Dolby NR OFF	More than 57 dB
Noise Reduction Effect	
Dolby B-type NR ON	More than 10 dB (at 5 kHz)
Dolby C-type NR ON	More than 19 dB (at 5 kHz)
Harmonic Distortion	No more than 0.7% (0 dB)
Input (Sensitivity)	
LINE (INPUT)	63 mV (input impedance 52 kΩ)
MIC (REAR)	0.4 mV
Output (Reference level)	
LINE (OUTPUT)	316 mV (Output impedance 3.3 kΩ)
PHONES	0.9 mW (load impedance 8Ω, Headphone level control max.)

Subfunctions

- Dolby B-type and C-type NR Systems
- DOLBY HX PRO system
- MPX FILTER (Interlocks with Dolby NR switch)
- Auto tape selector (NORM/CrO₂/METAL)
- Blank search
- Headphones jack with level control
- 4-digit electronic tape/time indicator
(Displays the operation mode in 5 digits)
- Music search up to ± 15 selections
- Automatic space recording mute
- AUTO BLE calibration system
- FL level meter 10 + 1 segments
- Timer Recording/Playback (Automatic repeat ON)
-  System remote control available
- CD-DECK synchro recording capability
- Microphone jacks (Rear panel)

Miscellaneous

Power Requirements

European model	a.c. 220 Volts~, 50/60 Hz
U.K. model	a.c. 240 Volts~, 50/60 Hz

Power Consumption 20 W

Dimensions 420 (W) × 130 (H) × 272 (D)mm
16-9/16 (W) × 5-1/8 (H) × 10-5/8 (D) in

Weight (without package) 4.3 kg (9 lb 7 oz)

Accessories

Operating instructions	1
Connection cord with pin plugs	2
CD-Deck synchro control cord	1
 System remote control cord	1

NOTE:

Specifications and design subject to possible modifications without notice, due to improvements.