

HCD-GRX7/GRX7J/R700/ RX77/RX77S

SERVICE MANUAL

Canadian Model
HCD-RX77

AEP Model
HCD-R700/RX77/RX77S

UK Model
HCD-R700/RX77S

E Model
HCD-GRX7/GRX7J

Australian Model
HCD-GRX7

Tourist Model
HCD-GRX7J



Photo: HCD-RX77

HCD-GRX7/GRX7J/R700/RX77/RX77S are the Amplifier, CD player, Tape Deck and Tuner section in MHC-GRX7/GRX7J/R700/RX77/RX77S.

Dolby noise reduction manufactured under license from Dolby Laboratories Licensing Corporation. "DOLBY" and the double-D symbol \square are trademarks of Dolby Laboratories Licensing Corporation.

CD Section	Model Name Using Similar Mechanism	HCD-H991AV
	CD Mechanism Type	CDM38L-5BD29AL/ CDM38LH-5BD29AL
	Base Unit Type	BU-5BD29AL
	Optical Pick-up Type	KSS-213D/Q-NP
TAPE DECK Section	Model Name Using Similar Mechanism	NEW
	Tape Transport Mechanism Type	TCM-230AWR1/ 230PWR1

SPECIFICATIONS

Amplifier section

Canadian model:

Continuous RMS power output (reference)
100 + 100 watts
(8 ohms at 1 kHz, 10% THD)

Total harmonic distortion less than 0.07%
(8 ohms at 1 kHz, 55 W)

European and Russian models:

DIN power output (rated) 60 + 60 watts
(6 ohms at 1 kHz, DIN)

Continuous RMS power output (reference)
80 + 80 watts
(6 ohms at 1 kHz, 10% THD)

Music power output (reference)
135 + 135 watts
(6 ohms at 1 kHz, 10% THD)

Other models:

The following measured at AC 110, 220 V 50/60 Hz

DIN power output (rated) 85 + 85watts
(8 ohms at 1 kHz, DIN)

Continuous RMS power output (reference)
110 + 110 watts
(8 ohms at 1 kHz, 10% THD)

The following measured at AC 120, 240 V 50/60 Hz

DIN power output (rated) 105 + 105 watts
(8 ohms at 1 kHz, DIN)

Continuous RMS power output (reference)
130 + 130 watts
(8 ohms at 1 kHz, 10% THD)

Peak music power output (reference)
1500 watts

– Continued on next page –

MINI Hi-Fi COMPONENT SYSTEM



SONY®

Specifications (continued)

Inputs	
MD/VIDEO IN: (phono jacks)	voltage 450 mV/250mV, impedance 47 kilohms
MIX MIC: (phone jack)	sensitivity 1 mV, impedance 10 kilohms
Outputs	
MD/VIDEO OUT: (phono jacks)	voltage 250 mV, impedance 1 kilohms
PHONES: (stereo phone jack)	accepts headphones of 8 ohms or more
SPEAKER:	
European and Russian models:	accepts impedance of 6 to 16 ohms
Other models:	accepts impedance of 8 to 16 ohms
SURROUND SPEAKER (Canadian model):	accepts impedance of 16 ohms
SUPER WOOFER (GRX7/GRX7J/RX77: Canadian models):	Voltage 1 V, impedance 1 kilohm

CD player section

System	Compact disc and digital audio system
Laser	Semiconductor laser ($\lambda=780\text{nm}$) Emission duration: continuous
Laser output	Max. 44.6 μW * *This output is the value measured at distance of 200 mm from the objective lens surface on the Optical Pick-up Block with 7 mm aperture.
Frequency response	2 Hz - 20 kHz (± 0.5 dB)
Wavelength	780 - 790 nm
Signal-to-noise ratio	More than 90 dB
Dynamic range	More than 90 dB
CD OPTICAL DIGITAL OUT (Square optical connector jack, rear panel)	
Wavelength	600 nm
Output Level	-18 dBm

Tape player section

Recording system	4-track 2-channel stereo
Frequency response (DOLBY NR OFF)	40 - 13,000 Hz (± 3 dB), using Sony TYPE I cassette 40 - 14,000 Hz (± 3 dB), using Sony TYPE II cassette

Tuner section

FM stereo, FM/AM superheterodyne tuner

FM tuner section

Tuning range	87.5 - 108.0 MHz
Antenna	FM lead antenna
Antenna terminals	75 ohm unbalanced
Intermediate frequency	10.7 MHz

UKV tuner section (4 band models only)

Tuning range	65.0 - 74.0 MHz Stereo Plus
--------------	--------------------------------

AM tuner section

Tuning range	
2 Band type:	
Canadian model:	530 - 1,710 kHz (with the interval set at 10 kHz) 531 - 1,710 kHz (with the interval set at 9 kHz)
Other model:	531 - 1,602 kHz (with the interval set at 9 kHz) 530 - 1,710 kHz (with the interval set at 10 kHz)
3 Band/4 Band type:	
European and Russian models:	
MW:	531 - 1,602 kHz (with the interval set at 9 kHz)
LW:	153 - 279 kHz (with the interval set at 3 kHz)

Middle Eastern models:	
MW:	531 - 1,602 kHz (with the interval set at 9 kHz)
SW:	5.95 - 17.90 MHz (with the interval set at 5 kHz)
Other models:	
MW:	531 - 1,602 kHz (with the interval set at 9 kHz) 530 - 1,710 kHz (with the interval set at 10 kHz)
SW:	5.95 - 17.90 MHz (with the interval set at 5 kHz)
Antenna	AM loop antenna
Antenna terminals	External antenna terminal
Intermediate frequency	450 kHz

General

Power requirements	
Canadian model:	120 V AC, 60 Hz
European and Russian models:	230 V AC, 50/60 Hz
Mexican model:	120 V AC, 50/60 Hz
Australian and Israel models:	220 - 240 V AC, 50/60 Hz
Thai model:	220 - 240 V AC, 50/60 Hz
Other models:	110 - 120 V or 220 - 240 V AC, 50/60 Hz
Power consumption	
Canadian model:	195 watts
European and Russian models:	140 watts
Other models:	250 watts
Dimensions (w/h/d)	Approx. 280 \times 335 \times 380 mm (11 ¹ / ₈ \times 13 ¹ / ₈ \times 15 in.)
Mass	
Canadian model:	Approx. 9.5 kg (20 lbs. 15 oz.)
European and Russian models:	Approx. 9.1 kg (20 lbs. 1 oz.)
Other models:	Approx. 10.2 kg (22 lbs. 8 oz.)
Supplied accessories:	AM loop antenna (1) Remote RM-SR5 (1) Batteries (2) FM lead antenna (1) Speaker cords (2) Front speaker pads (8)

Design and specifications are subject to change without notice.

SECTION 1 SERVICING NOTES

TABLE OF CONTENTS

1. SERVICING NOTES	3
2. GENERAL	
Location of Controls	6
Setting the Time	7
3. DISASSEMBLY	8
4. TEST MODE	11
5. MECHANICAL ADJUSTMENTS	13
6. ELECTRICAL ADJUSTMENTS	
DECK Section	13
TUNER Section	16
CD Section	18
7. DIAGRAMS	20
7-1. Block Diagram – TUNER Section (AEP, UK, German models only) –	21
7-2. Block Diagram – TUNER Section (East European, CIS models only) –	23
7-3. Block Diagram – CD MECHANISM DECK Section –	25
7-4. Block Diagram – TAPE DECK Section –	27
7-5. Block Diagram – MAIN Section –	29
7-6. Block Diagram – DISPLAY/KEY CONTROL/ POWER SUPPLY Section –	31
7-7. Schematic Diagram – TUNER Section (AEP, UK, German models only) –	35
7-8. Printed Wiring Board – TUNER Section (AEP, UK, German models only) –	37
7-9. Printed Wiring Board – TUNER Section (East European, CIS models only) –	38
7-10. Schematic Diagram – TUNER Section (East European, CIS models only) –	39
7-11. Printed Wiring Board – CD Section –	41
7-12. Schematic Diagram – CD Section –	43
7-13. Printed Wiring Boards – CD MOTOR Section –	45
7-14. Schematic Diagram – CD MOTOR Section –	47
7-15. Printed Wiring Board – TAPE DECK Section –	49
7-16. Schematic Diagram – TAPE DECK Section –	51
7-17. Printed Wiring Board – LEAF SW Section –	53
7-18. Schematic Diagram – LEAF SW Section –	53
7-19. Printed Wiring Board – MAIN Section –	55
7-20. Schematic Diagram – MAIN Section (1/4) –	57
7-21. Schematic Diagram – MAIN Section (2/4) –	59
7-22. Schematic Diagram – MAIN Section (3/4) –	61
7-23. Schematic Diagram – MAIN Section (4/4) –	63
7-24. Printed Wiring Board – PANEL Section –	65
7-25. Schematic Diagram – PANEL Section –	67
7-26. Printed Wiring Board – CD-SW Section –	69
7-27. Schematic Diagram – CD-SW Section –	69
7-28. Printed Wiring Board – HP Section –	71
7-29. Schematic Diagram – HP Section –	71
7-30. Printed Wiring Board – POWER AMP Section –	72
7-31. Schematic Diagram – POWER AMP Section –	73
7-32. Printed Wiring Board – TRANSFORMER Section –	75
7-33. Schematic Diagram – TRANSFORMER Section –	76
7-34. IC Pin Function Description	82
8. EXPLODED VIEWS	87
9. ELECTRICAL PARTS LIST	96

NOTES ON HANDLING THE OPTICAL PICK-UP BLOCK OR BASE UNIT

The laser diode in the optical pick-up block may suffer electrostatic break-down because of the potential difference generated by the charged electrostatic load, etc. on clothing and the human body.

During repair, pay attention to electrostatic break-down and also use the procedure in the printed matter which is included in the repair parts.

The flexible board is easily damaged and should be handled with care.

NOTES ON LASER DIODE EMISSION CHECK

The laser beam on this model is concentrated so as to be focused on the disc reflective surface by the objective lens in the optical pick-up block. Therefore, when checking the laser diode emission, observe from more than 30 cm away from the objective lens.

Notes on chip component replacement

- Never reuse a disconnected chip component.
- Notice that the minus side of a tantalum capacitor may be damaged by heat.

Flexible Circuit Board Repairing

- Keep the temperature of the soldering iron around 270 °C during repairing.
- Do not touch the soldering iron on the same conductor of the circuit board (within 3 times).
- Be careful not to apply force on the conductor when soldering or unsoldering.

CAUTION

Use of controls or adjustments or performance of procedures other than those specified herein may result in hazardous radiation exposure.

This appliance is classified as a CLASS 1 LASER product. The CLASS 1 LASER PRODUCT MARKING is located on the rear exterior.

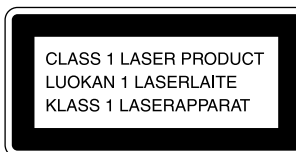

Laser component in this product is capable of emitting radiation exceeding the limit for Class 1.

The following caution label is located inside the unit.



SAFETY-RELATED COMPONENT WARNING!!

COMPONENTS IDENTIFIED BY MARK \triangle OR DOTTED LINE WITH MARK \triangle ON THE SCHEMATIC DIAGRAMS AND IN THE PARTS LIST ARE CRITICAL TO SAFE OPERATION. REPLACE THESE COMPONENTS WITH SONY PARTS WHOSE PART NUMBERS APPEAR AS SHOWN IN THIS MANUAL OR IN SUPPLEMENTS PUBLISHED BY SONY.

ATTENTION AU COMPOSANT AYANT RAPPORT À LA SÉCURITÉ!

LES COMPOSANTS IDENTIFIÉS PAR UNE MARQUE \triangle SUR LES DIAGRAMMES SCHÉMATIQUES ET LA LISTE DES PIÈCES SONT CRITIQUES POUR LA SÉCURITÉ DE FONCTIONNEMENT. NE REMPLACER CES COMPOSANTS QUE PAR DES PIÈCES SONY DONT LES NUMÉROS SONT DONNÉS DANS CE MANUEL OU DANS LES SUPPLÉMENTS PUBLIÉS PAR SONY.

MODEL IDENTIFICATION

– Back Panel –

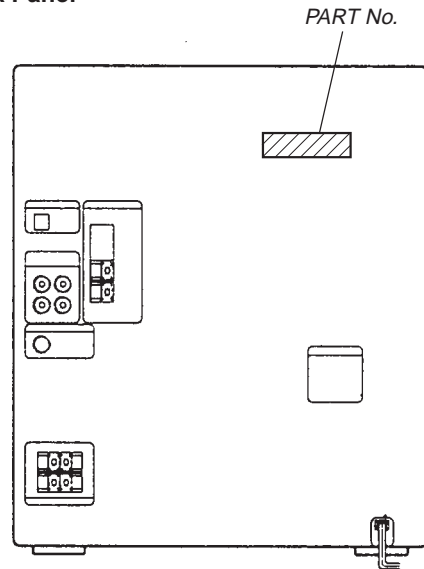

MODEL	PART No.
Canadian model	4-996-843-0□
Israel and Thai models	4-996-843-6□
E model	4-996-844-0□
Malaysia, Singapore and South African models	4-996-844-1□
GRX7: Saudi Arabia and Taiwan models	4-996-844-2□
Hong Kong model	4-996-844-3□
Australian model	4-996-844-4□
Mexican model	4-996-844-5□
Indonesian model	4-996-844-7□
GRX7J	4-996-844-8□
RX77S: UK model	4-996-845-0□
RX77S: East European and CIS model	4-996-845-1□
R700	4-996-845-2□
RX77: AEP and German model	4-996-845-3□
RX77: East European model	4-996-845-4□

HOW TO OPEN THE DISC TRAY WHEN POWER SWITCH TURNS OFF.

❶ Remove the Case.

❸ Pull-out the disc tray.

❷ Turn the cam to the direction of arrow.

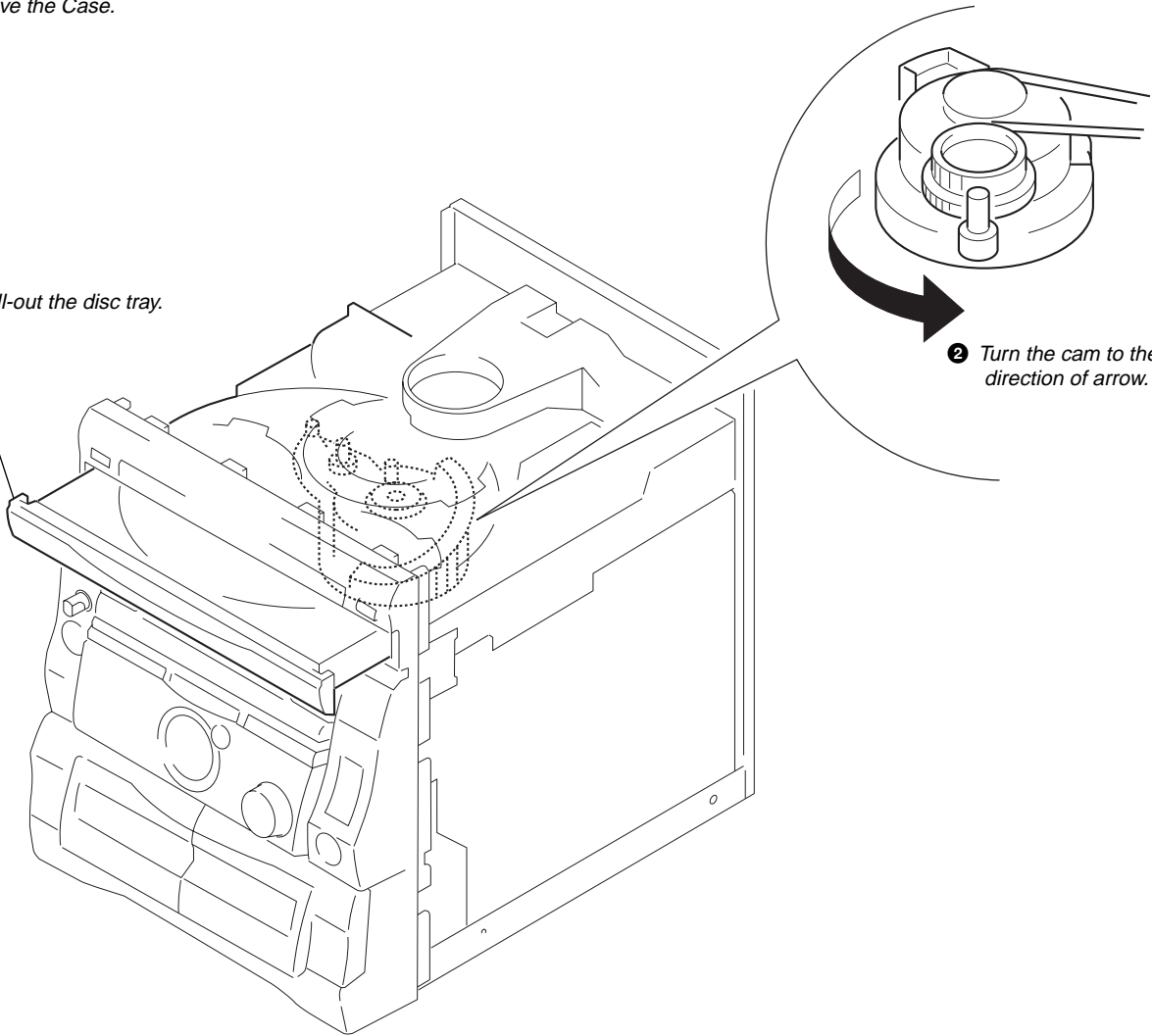

NOTE FOR INSTALLATION (ROTARY ENCODER)

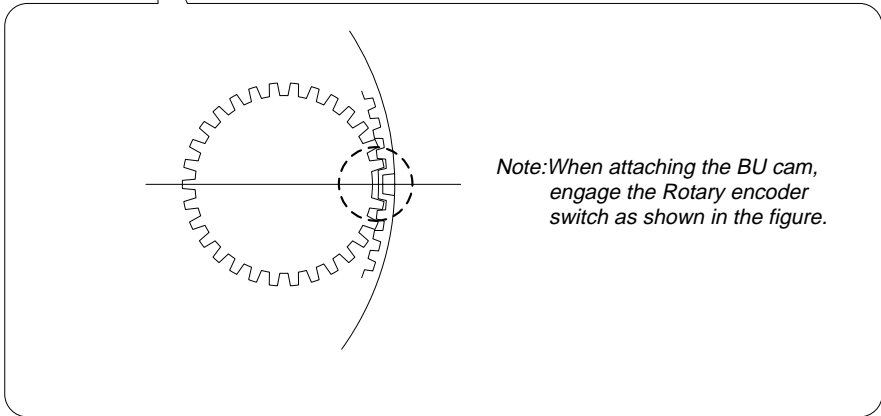
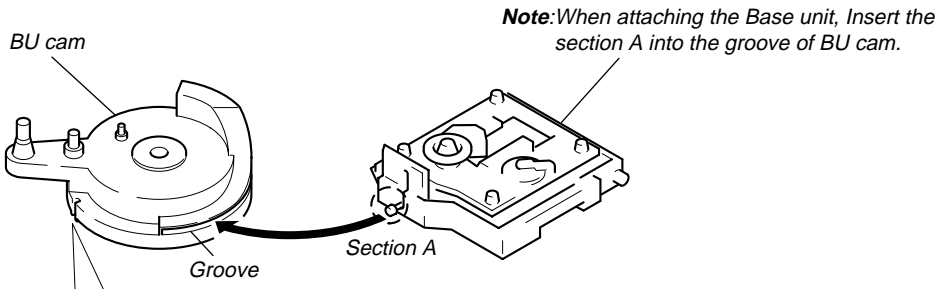

SECTION 2 GENERAL

LOCATION OF CONTROLS

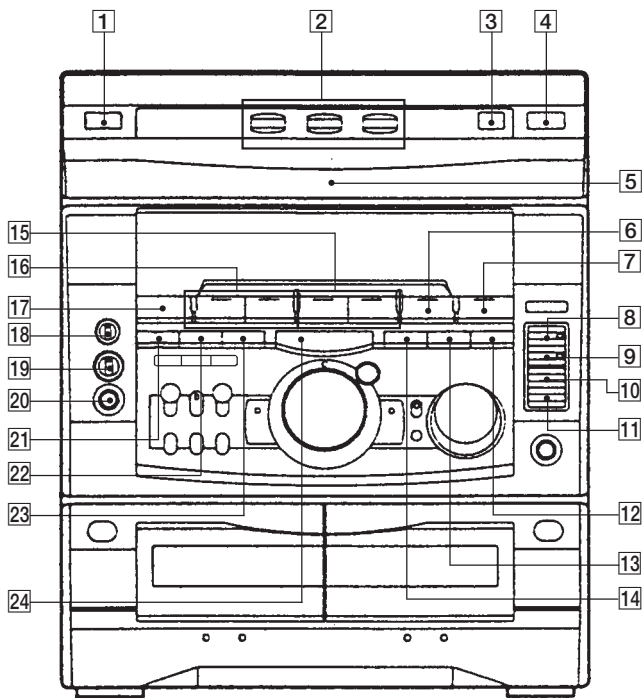

- 1 I / ⏻ (Power) button
- 2 DISC 1 to 3 buttons and indicators
- 3 DISC SKIP/EX-CHANGE button
- 4 ▲ (CD) button
- 5 CD disc tray
- 6 CD ►|| button and indicator
- 7 TUNER, BAND button
- 8 ● REC button and indicator
- 9 || PAUSE button and indicator
- 10 HI-DUB button
- 11 CD SYNC button
- 12 EFFECT button and indicator
(GRX7/GRX7J/RX77: Canadian models)
FILE SELECT button (AEP, UK, German, East European, and CIS models)
- 13 SURROUND button
- 14 KARAOKE PON/MPX button
- 15 DECK B ◀ and ▶ buttons and indicators
- 16 DECK A ◀ and ▶ buttons and indicators
- 17 FUNCTION button
- 18 ECHO LEVEL knob (Saudi Arabia model)
- 19 MIC LEVEL knob
- 20 MIX MIC jac
- 21 DISPLAY/DEMO button
- 22 CLOCK/TIMER SET button
- 23 TIMER SELECT button
- 24 ■ button

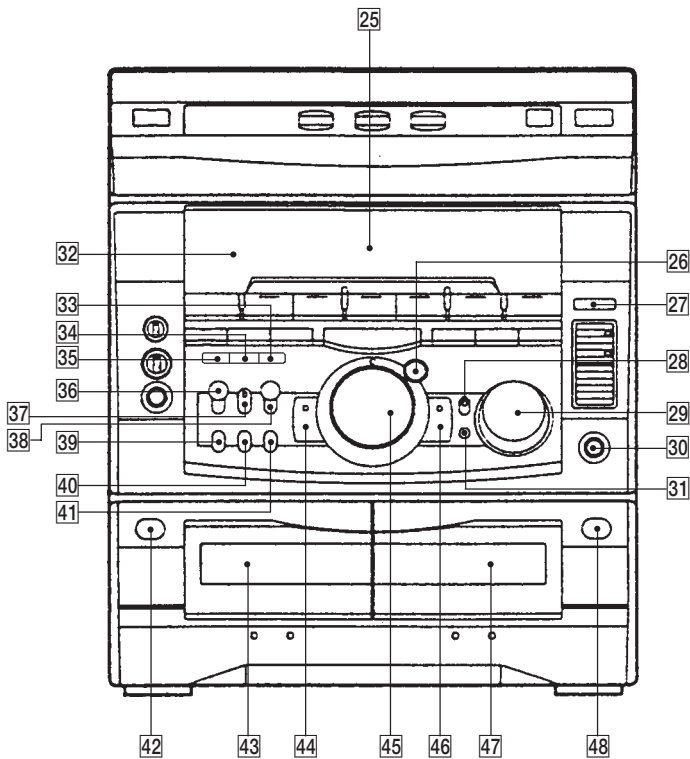

- 25 Fluorescent indicator tube
- 26 ENTER/NEXT button and indicator
- 27 PTY button (AEP, UK, and German models)
- 28 GROOVE button and indicator
- 29 VOLUME knob
- 30 PHONES jack
- 31 DBFB button
- 32 Remote sensor
- 33 P FILE MEMORY button (GRX7/GRX7J/RX77: Canadian models)
- 34 GEQ CONTROL button (GRX7/GRX7J/RX77: Canadian models)
- 35 FILE SELECT button (GRX7/GRX7J/RX77: Canadian models)
- 36 LOOP button
- 37 NON-STOP button and indicator
- 38 FLASH button
- 39 EDIT, DIRECTION button
- 40 PLAY MODE, DOLBY NR button
- 41 REPEAT button
- 42 ≡ button (deck A)
- 43 Tape deck A
- 44 -, ◀ button and indicator
- 45 JOG dial
- 46 +, ▶ button and indicator
- 47 Tape deck B
- 48 ≡ button (deck B)

Step 2: Setting the time

You must set the time before using the timer functions.

The clock is on a 24-hour system for the European model, and a 12-hour system for other models.

The 12-hour system model is used for illustration purposes.

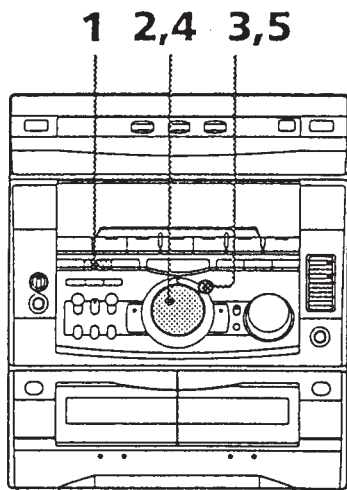

- 1 Press **CLOCK/TIMER SET**.
The hour indication flashes.

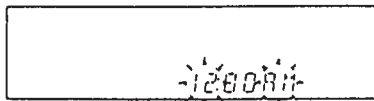

- 2 Turn the jog dial to set the hour.

- 3 Press **ENTER/NEXT**.
The minute indication flashes.



- 4 Turn the jog dial to set the minute.

- 5 Press **ENTER/NEXT**.
The clock starts working.

Tips

- If you've made a mistake, start over from step 1.
- Setting the time deactivates the demo mode.
If you want to display the demo mode, press **DISPLAY/DEMO** when the power is off.

Note

The previous explanation shows you how to set the time while the power is off. To change the time while the power is on, do the following:

- 1 Press **CLOCK/TIMER SET**.
- 2 Turn the jog dial to select **SET CLOCK**.
- 3 Press **ENTER/NEXT**.
- 4 Perform steps 2 through 5 above.

SECTION 3 DISASSEMBLY

Note: Follow the disassembly procedure in the numerical order given.

CASE

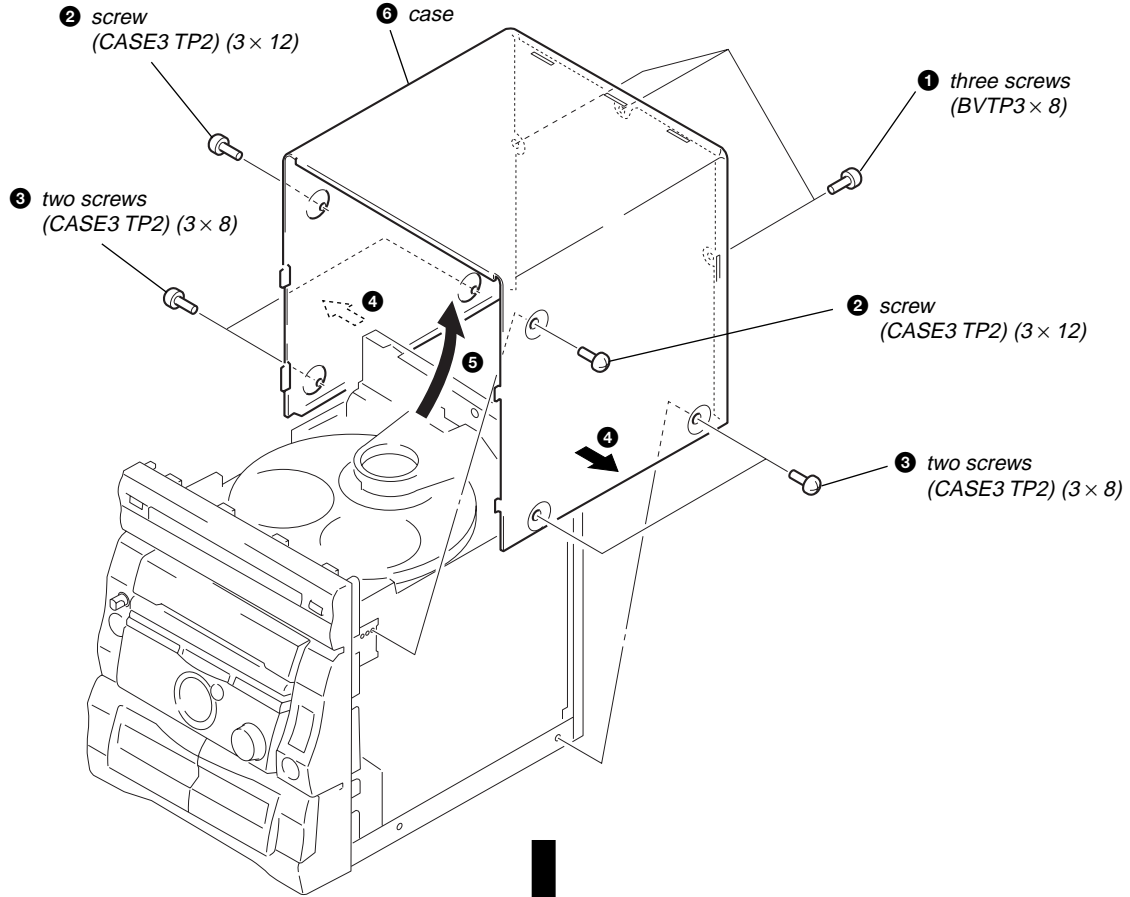

FRONT PANEL SECTION

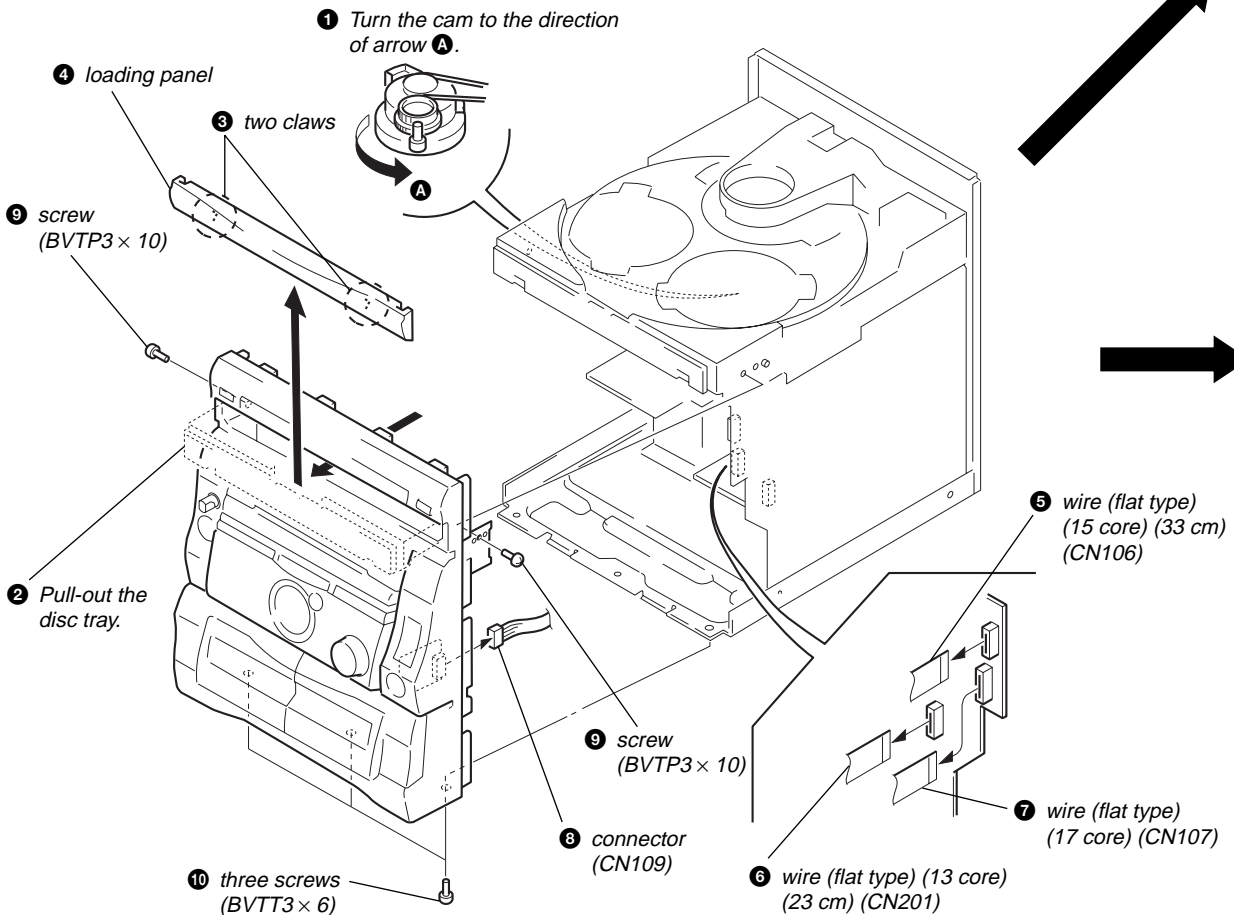

TAPE MECHANISM DECK SECTION (TCM-230AWR1/TCM-230PWR1)

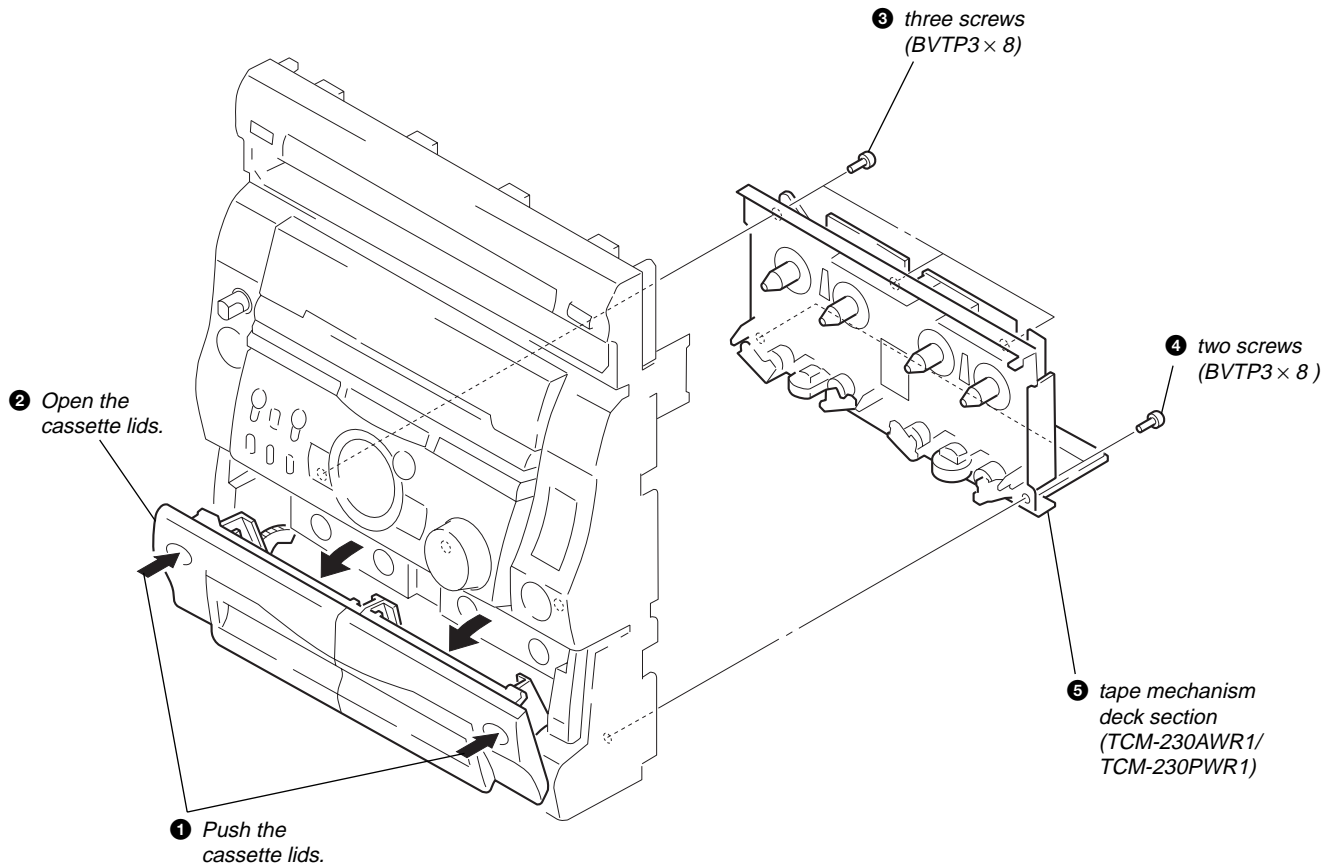

CD MECHANISM DECK SECTION (CDM38L-5BD29AL/CDM38LH-5BD29AL)

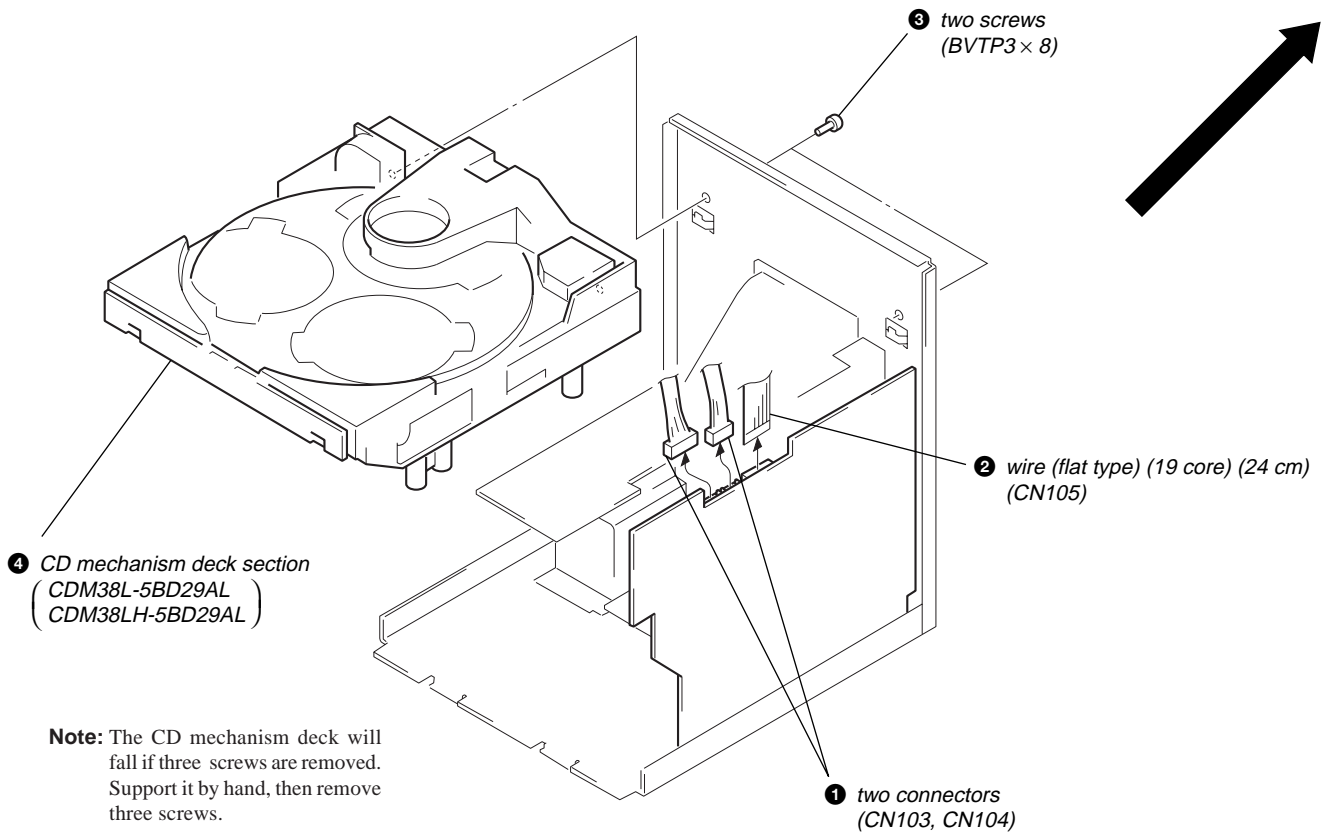

MAIN BOARD

Abbreviation

AUS : Australian

CND: Canadian

E2 : 120 V AC Area in E model

E3 : 240 V AC Area in E model

EA3 : Saudi Arabia

EA4 : Israel

EE : East European

G : German

HK : Hong Kong

IA : Indonesian

MX : Mexican

MY : Malaysia

SAF : South African

SP : Singapore

TH : Thai

TW : Taiwan

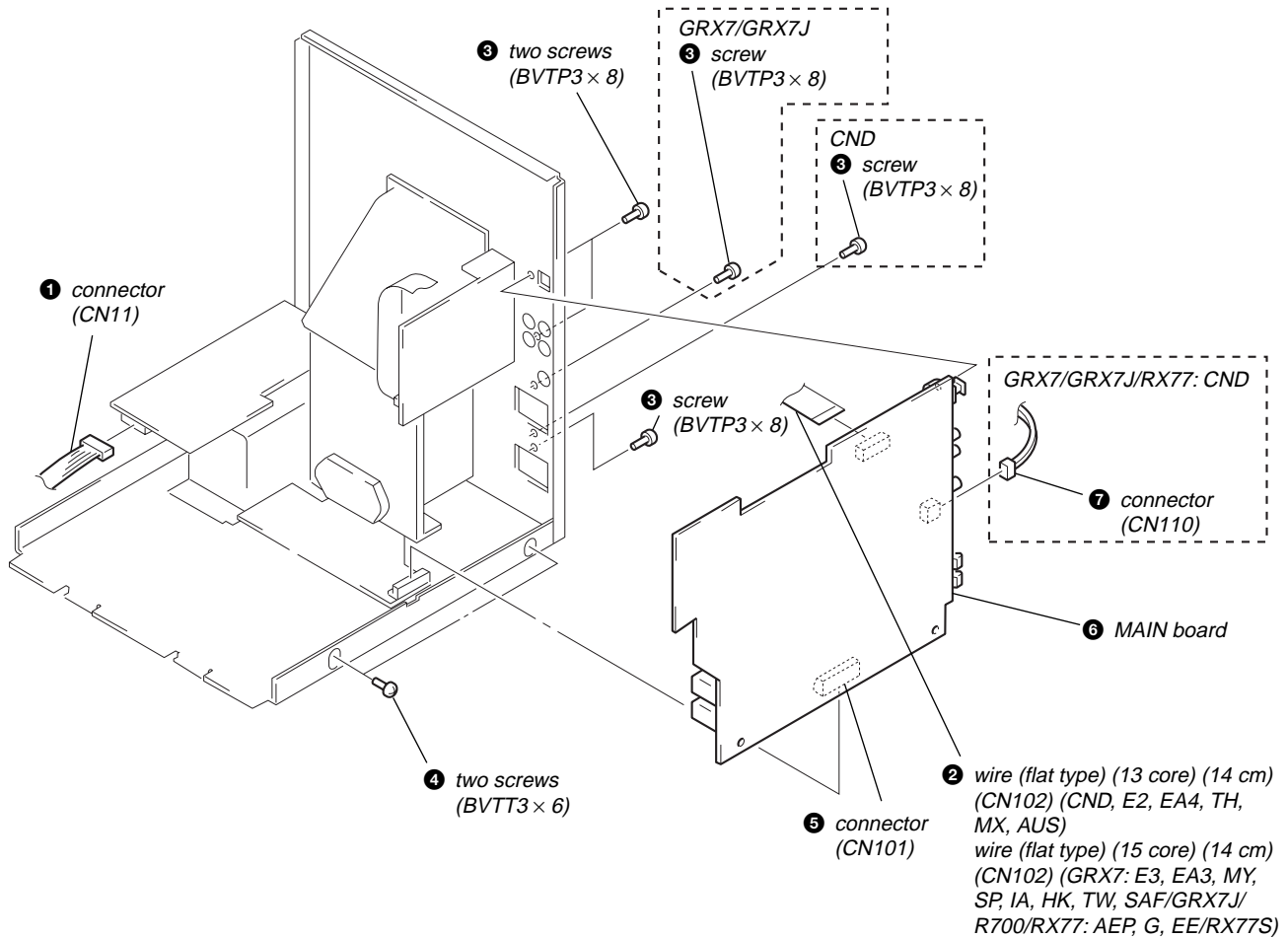



SECTION 4 TEST MODE

[MC Cold Reset]

- The cold reset clears all data including preset data stored in the RAM to initial conditions. Execute this mode when returning the set to the customer.



Procedure:

1. Press three buttons , [ENTER/NEXT], and  simultaneously.
2. The fluorescent indicator tube becomes blank instantaneously, and the set is reset.

[CD Delivery Mode]

- This mode moves the pickup to the position durable to vibration. Use this mode when returning the set to the customer after repair.



Procedure:

1. Press  button to turn the set ON.
2. Press  button and  button simultaneously.
3. A message “LOCK” is displayed on the fluorescent indicator tube, and the CD delivery mode is set.

[MC Hot Reset]

- This mode resets the set with the preset data kept stored in the memory. The hot reset mode functions same as if the power cord is plugged in and out.





Procedure:

1. Press three buttons , [ENTER/NEXT], and  simultaneously.
2. The fluorescent indicator tube becomes blank instantaneously, and the set is reset.

[Sled Servo Mode]

- This mode can run the CD sled motor freely. Use this mode, for instance, when cleaning the pickup.

Procedure:





1. Press  button to turn the set ON.
2. Select the function “CD”.
3. Press three buttons , [ENTER/NEXT], and  simultaneously.
4. The Sled Servo mode is selected, if “CD” is blanking on the fluorescent indicator tube.
5. With the CD in stop status, press  button to move the pickup to outside track, or  button to inside track.
6. To exit from this mode, perform as follows:
 - 1) Move the pickup to the most inside track.
 - 2) Press three buttons in the same manner as step 2.

- Note:**
- Always move the pickup to most inside track when exiting from this mode. Otherwise, a disc will not be unloaded.
 - Do not run the sled motor excessively, otherwise the gear can be chipped.

[Change-over of AM Tuner Step between 9 kHz and 10 kHz]





- A step of AM channels can be changed over between 9 kHz and 10 kHz.

Procedure:

1. Press  button to turn the set ON.
2. Select the function “TUNER”, and press  button to select the BAND “AM”.
3. Press  button to turn the set OFF.
4. Press  and  buttons simultaneously, and the display of fluorescent indicator tube changes to “AM 9 k STEP” or “AM 10 k STEP”, and thus the channel step is changed over.

[LED and Fluorescent Indicator Tube All Lit, Key Check Mode]

Procedure:





1. Press three buttons , [ENTER/NEXT], and  simultaneously.
2. LEDs and fluorescent indicator tube are all turned on. Press  button, and the key check mode is activated.
3. In the key check mode, the fluorescent indicator tube displays “K 1 J0 V0”. Each time a button is pressed, “K” value increases. However, once a button is pressed, it is no longer taken into account.
 - “J” value increases like 1, 2, 3 ... if rotating  knob in “+” direction, or it decreases like 0, 9, 8 ... if rotating in “-” direction.
 - “V” value increases like 1, 2, 3 ... if rotating  knob in “+” direction, or it decreases like 0, 9, 8 ... if rotating in “-” direction.
4. To exit from this mode, press three buttons in the same manner as step 1, or disconnect the power cord.

[Aging Mode]

This mode can be used for operation check of CD section and tape deck section.

- If an error occurred:
The aging operation stops and display status.
- If no error occurs:
The aging operation continues repeatedly.

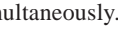
1. Operating Method of Aging Mode

- 1) Set disc in DISC1 tray.
- 2) Load the tapes recording use into the decks A and B respectively.
- 3) Press three buttons , , and  simultaneously.
- 4) The aging mode is activated, if a CD roulette mark on the fluorescent indicator tube is blinking.
- 5) To exit from the aging mode, press  button to turn the set OFF.

2. Operation Sequence

- During the aging mode in the following sequence to below.
- Starting the CD section aging for function set “CD”, starting the TAPE section (deck A) aging for function set “TAPE A” or “TAPE B”. (Set another function is no work.)

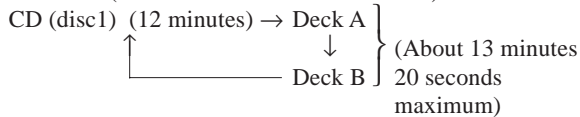

3. Aging mode in CD section

- 1) Display state

- No error occurs

display

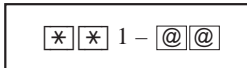

Note:

: a letter “CD” and the remainder time (minute) alternately. (remainder time start from 12 minute)

: track number in access.

- Error occurred

NO.	Display	Main factor
1	NO DISC ERR	Not set disc in DISC1
2	FOCUS1 ERR	Focus does not work
3	FOCUS2 ERR	Focus does not work after the disc rotate as usual
4	GFS ERR	GFS error
5	FBIAS ERR	Error in to the focus bias adjustment
6	SENSOR ERR	Disc sensor sens DISC1 is no disc
7	TABLE ERR	CD tray lotate does not work
8	TRAY ERR	Tray (include BD) move does not work

2) Operation during aging Mode

In the aging mode, the program is executed in the following sequence.

- (1) The disc tray turns to select a disc1.
- (2) A disc is chucked.
- (3) TOC of disc is read.
- (4) The pickup accesses to the track 1, and playing 2 seconds.
- (5) The pickup accesses to the last track, and playing 2 seconds.
- (6) Steps 1 through 5 are repeated about 12 minutes.
- (7) Change to deck section aging.

4. Aging mode in Tape Deck section

- 1) Display state
- No error occurs
Display action now
 - Error occurred
Display action last time

NO.	Display action	Action contents	Final timing
1	TAPE A AG-1	Rewind the TAPE A	The top of tape
2	TAPE A AG-2	FWD play the TAPE A	3 minutes playing
3	TAPE A AG-3	F.F. the TAPE A	First either 20 minutes or the end of tape
4	TAPE A AG-4	REV play the TAPE A	3 minutes playing
5	TAPE A AG-5	Rewind the TAPE A	The top of tape
6	TAPE B AG-1	Rewind the TAPE B	The top of tape
7	TAPE B AG-2	FWD play the TAPE B	3 minutes playing
8	TAPE B AG-3	F.F. the TAPE B	First either 20 minutes or the end of tape
9	TAPE B AG-4	REV play the TAPE B	3 minutes playing
10	TAPE B AG-5	Rewind the TAPE B	The top of tape

2) Operation during Aging Mode

In the aging mode, the program is executed in the following sequence.

- (1) Rewind is executed up to the top of tape.
- (2) A tape on FWD side is played for 3 minutes.
- (3) FF is executed up to either made for 20 minutes or the end of tape.
- (4) A tape is reversed, and the tape on REV side is played for 3 minutes.
- (5) Rewind is executed up to the top of tape.
- (6) Steps 1 through 5 are executed for the other deck.
- (7) Change to CD section aging.

SECTION 5 MECHANICAL ADJUSTMENTS

Precaution

1. Clean the following parts with a denatured alcohol-moistened swab:

record/playback heads	pinch rollers
erase head	rubber belts
capstan	idlers
2. Demagnetize the record/playback head with a head demagnetizer.
3. Do not use a magnetized screwdriver for the adjustments.
4. After the adjustments, apply suitable locking compound to the parts adjusted.
5. The adjustments should be performed with the rated power supply voltage unless otherwise noted.

Torque Measurement

Mode	Torque meter	Meter reading
FWD	CQ-102C	31 to 71 g • cm (0.43 – 0.98 oz • inch)
FWD back tension	CQ-102C	2 to 6 g • cm (0.03 – 0.08 oz • inch)
REV	CQ-102RC	31 to 71 g • cm (0.43 – 0.98 oz • inch)
REV back tension	CQ-102RC	2 to 6 g • cm (0.03 – 0.08 oz • inch)
FF/REW	CQ-201B	71 to 143 g • cm (0.99 – 1.99 oz • inch)
FWD tension	CQ-403A	100 g or more (3.53 oz or more)
REV tension	CQ-403R	100 g or more (3.53 oz or more)

SECTION 6 ELECTRICAL ADJUSTMENTS

DECK SECTION

0 dB=0.775 V

1. Demagnetize the record/playback head with a head demagnetizer.
2. Do not use a magnetized screwdriver for the adjustments.
3. After the adjustments, apply suitable locking compound to the parts adjust.
4. The adjustments should be performed with the rated power supply voltage unless otherwise noted.
5. The adjustments should be performed in the order given in this service manual. (As a general rule, playback circuit adjustment should be completed before performing recording circuit adjustment.)
6. The adjustments should be performed for both L-CH and R-CH.
7. Switches and controls should be set as follows unless otherwise specified.

• Test Tape

Tape	Signal	Used for
P-4-A100	10 kHz, -10 dB	Azimuth Adjustment
WS-48B	3 kHz, 0 dB	Tape Speed Adjustment
P-4-L300	315 Hz, 0 dB	Level Adjustment

Record/Playback Head Azimuth Adjustment

DECK A

DECK B

Note: Perform this adjustments for both decks

Procedure:

1. Mode: Playback

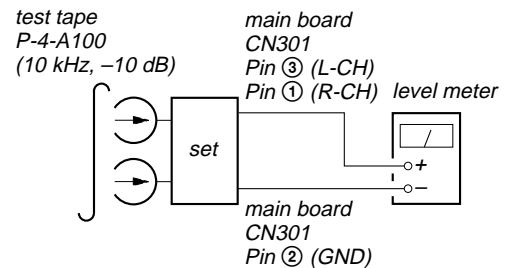

- Turn the adjustment screw and check output peaks. If the peaks do not match for L-CH and R-CH, turn the adjustment screw so that outputs match within 1dB of peak.

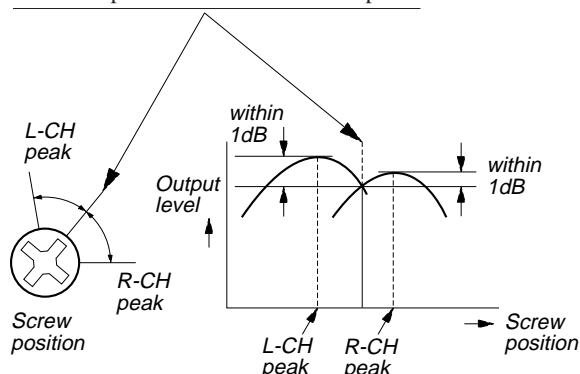

- Mode: Playback

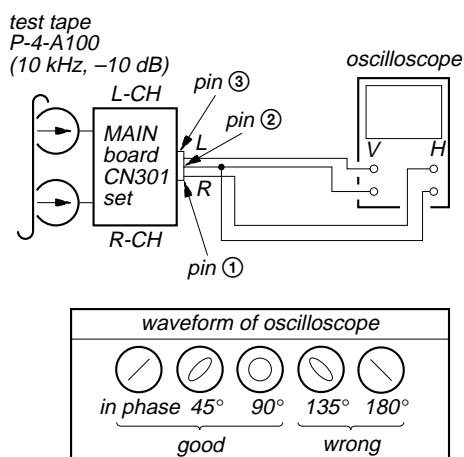

- After the adjustments, apply suitable locking compound to the parts adjusted.

Adjustment Location: Playback Head (Deck A).
Record/Playback/Erase Head (Deck B).

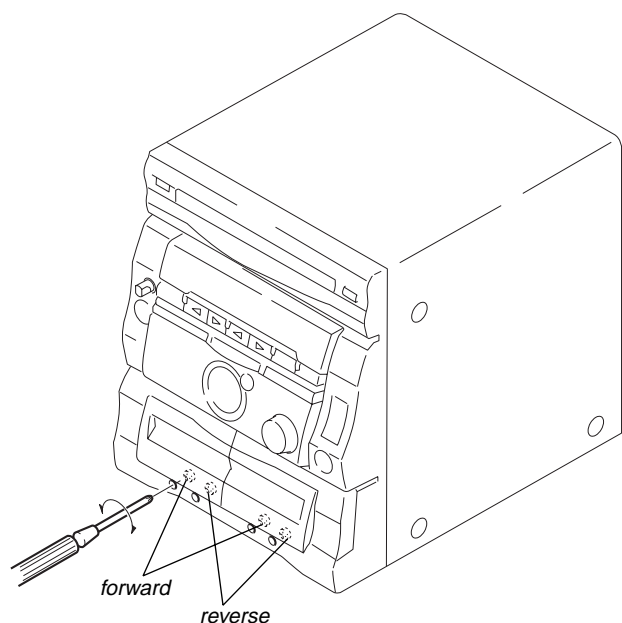

Tape Speed Adjustment **DECK B**

Note: Start the Tape Speed adjustment as below after setting to the test mode.

In the test mode, the tape speed is high during pressing the **HI-DUB** button.

Procedure:

- Turn the power switch on.
- Press the **STOP** button, **ENTER/NEXT** button and **DISC 3** button simultaneously.
(The "VOLUME" on the fluorescent indicator tube will blink while in the test mode.)
To exit from the test mode, press the **POWER** button.

Mode: Playback

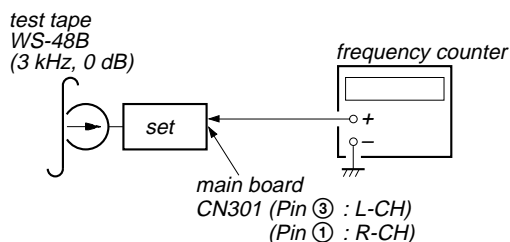

- Insert the WS-48B into the deck B.
- Press the **PLAY** button on the deck B.
- Press the **HI-DUB** button in playback mode.
Then at HIGH speed mode.
- Adjust RV1001 on the LEAF SW board so that frequency counter reads $6,000 \pm 180$ Hz.
- Press the **HI-DUB** button.
Then back to NORMAL speed mode.
- Adjust RV1002 on the LEAF SW board so that frequency counter reads $3,000 \pm 90$ Hz.

Adjustment Location: LEAF SW board

Sample value of Wow and Flutter: 0.3% or less W.RMS (JIS)
(WS-48B)

Playback level Adjustment **DECK A** **DECK B**

Procedure:

Mode: Playback

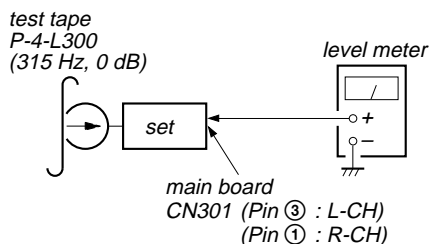

Deck A is RV311 (L-CH) and RV411 (R-CH), Deck B is RV301 (L-CH) and RV401 (R-CH) so that adjustment within adjustment level as follows.

Adjustment Level:

CN301 PB level: 301.5 to 338.3 mV (-8.2 to -7.2 dB) level
difference between the channels: within ± 0.5 dB

Adjustment Location: AUDIO board

REC Bias Adjustment **DECK B**

Procedure:

INTRODUCTION

When set to the test mode performed in Tape Speed Adjustment, when the tape is rewound after recording, the "REC memory mode" which rewinds only the recorded portion and playback is set.

This "REC memory mode" is convenient for performing this adjustment. During recording, the input signal FUNCTION will automatically switch to VIDEO.

(If do not operation of stopped from recording complete, and press button then rewind to recording start position.)

1. Press **FUNCTION** button to select VIDEO. (This step is not necessary if the above test mode has already been set.)
2. Insert a tape into deck B.
3. After press button, press button, then recording start.
4. Mode: Record

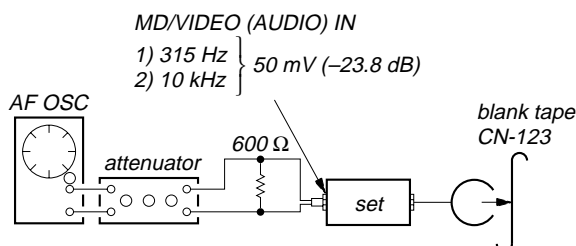

5. Mode: Playback

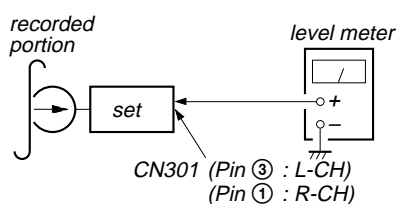

6. Confirm playback the signal recorded in step 3 become adjustable level as follows.
If these levels do not adjustable level, adjustment the RV341 (L-CH) and RV441 (R-CH) on the AUDIO board to repeat steps 4 and 5.

Adjustable level: Playback output of 315 Hz to playback output of 10 kHz: ± 1.0 dB

Adjustment Location: AUDIO board

REC Level Adjustment **DECK B**

Procedure:

INTRODUCTION

When set to the test mode performed in Tape Speed Adjustment, when the tape is rewound after recording, the "REC memory mode" which rewinds only the recorded portion and playback is set.

This "REC memory mode" is convenient for performing this adjustment. During recording, the input signal FUNCTION will automatically switch to VIDEO.

(If do not operation of stopped from recording complete, and press button then rewind to recording start position.)

1. Press **FUNCTION** button to select VIDEO. (This step is not necessary if the above test mode has already been set.)
2. Insert a tape into deck B.
3. After press button, press button, then recording start.

4. Mode: Record

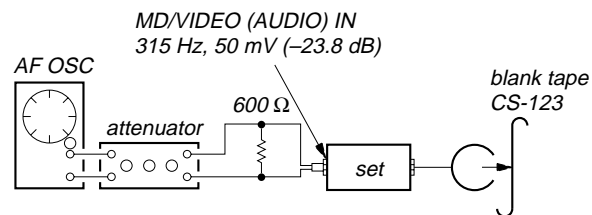

5. Mode: Playback

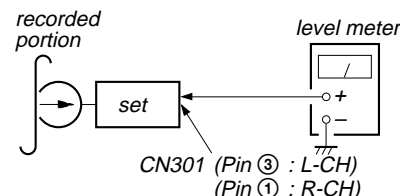

6. Confirm playback the signal recorded in step 3 become adjustable level as follows.

If these levels do not adjustable level, adjustment the RV301 (L-CH) and RV351 (R-CH) on the MAIN board to repeat steps 4 and 5.

Adjustable level:

CN301 PB level: 47.2 to 53.0 mV (-24.3 to -23.3 dB)

Adjustment Location: MAIN board

[MAIN BOARD] (Component Side)

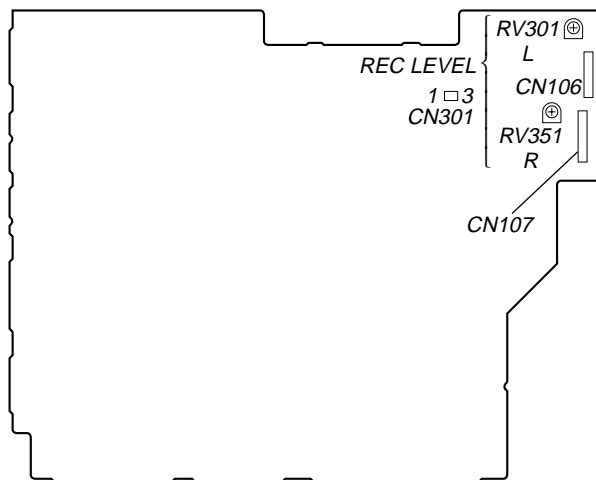

[AUDIO BOARD] (Component Side)

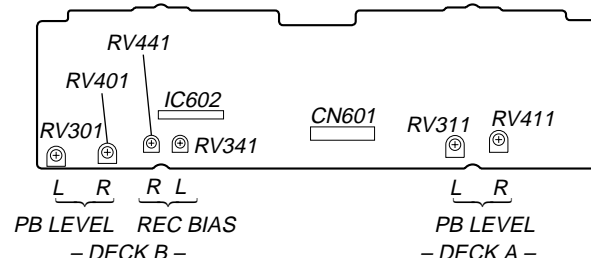

[LEAF SW BOARD] (Component Side)

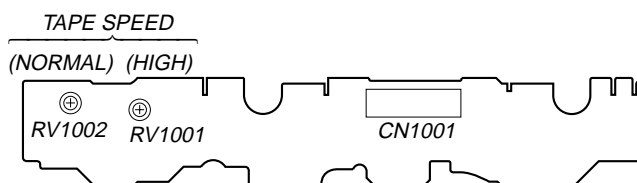

TUNER SECTION 0 dB=1 μV

(AEP, German, UK, East European, CIS models only)

Note: As a front-end (FE1) is difficult to repair if faulty, replace it with new one.

AM Section Adjustment

Note: FM Tuned Level Adjustment should be performed after this AM Tuned Level Adjustment.

Setting:

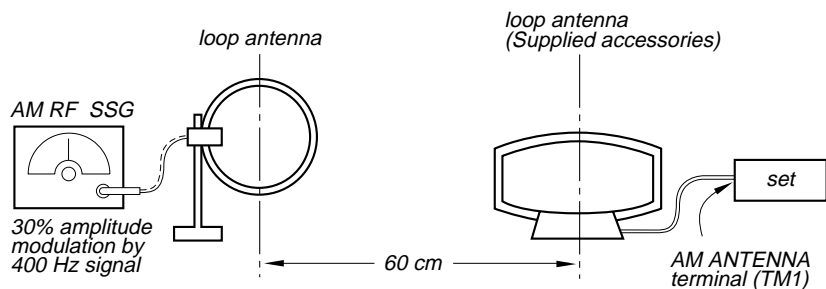

AM Tuned Level Adjustment

Band: MW

Procedure:

1. Set the output of SSG so that the input level of the set becomes 55 dB.
2. Tune the set to 999 kHz or 1,050 kHz.
3. Adjust RV41 to the point (moment) when the TUNED indicator will change from going off to going on.

Adjustment Location : TCB board

FM Section Adjustment

Note: This adjustment should be performed after the AM Tuned Level Adjustment due to the same adjustment element.

Setting:

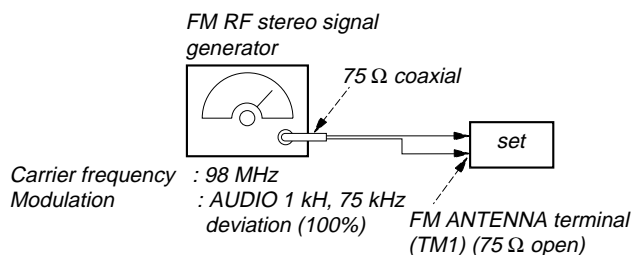

FM Tuned Level Adjustment

Band: FM

Procedure:

1. Supply a 25 dBμ 98 MHz signal from the ANTENNA terminal.
2. Tune the set to 98 MHz.
3. If the TUNED indicator does not light, adjust RV42 to the point (moment) when the TUNED indicator will change from going off to going on.

Adjustment Location: TCB board

Adjustment Location:

[TCB BOARD] (Component Side)

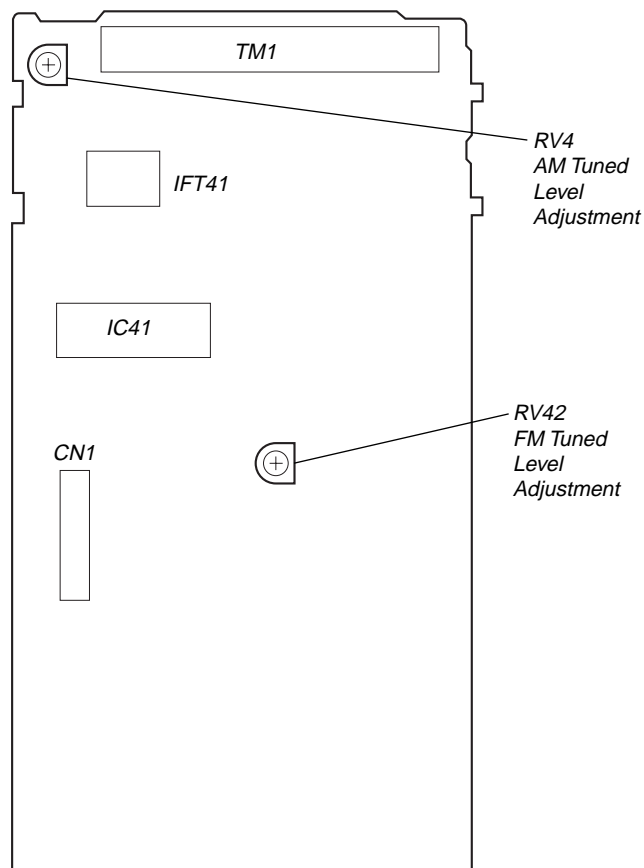

FM Polar Adjustment (East European, CIS models only)

Connection 1:

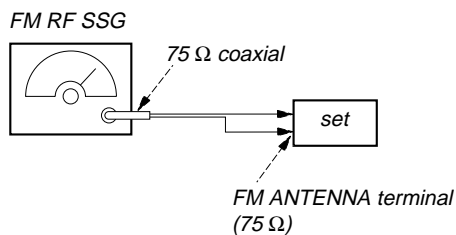

Carrier frequency: 69 MHz
 Output level : 1mV (60dBμ) (at 75 Ω open)
 Modulation : AUDIO 1 kHz, 10kHz deviation

Connection 2:

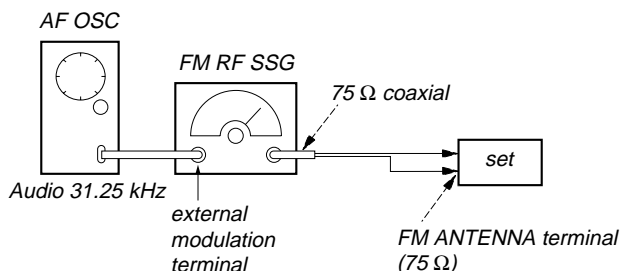

Carrier frequency: 69 MHz
 Output level : 1mV (60 dBμ) (at 75 Ω open)
 Modulation : AUDIO 31.25 kHz, 10 kHz deviation
 (EXTERNAL MODULATION)

Adjustment Location :

East European, CIS:

[TCB BOARD] (Component Side)

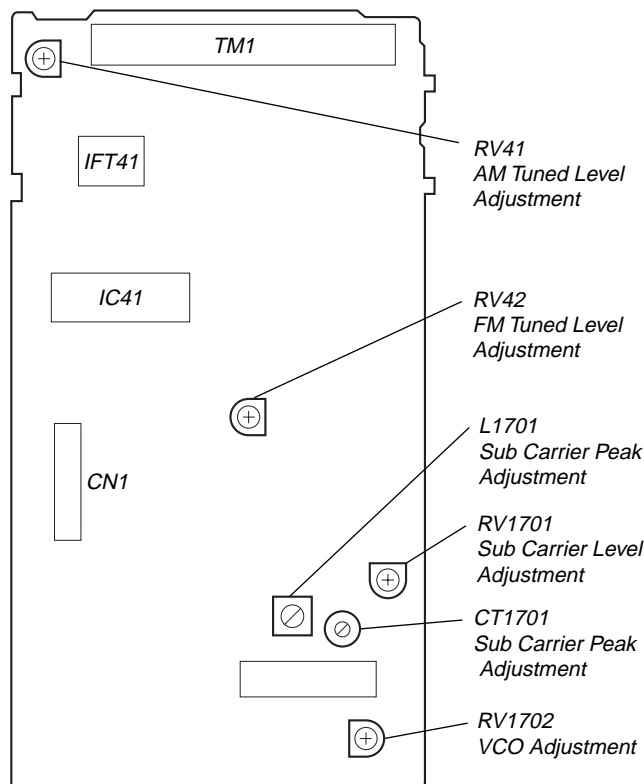

Procedure :

1. Set the modulation of FM RF SSG to AUDIO 1 kHz, 10 kHz deviation according to "Connection 1".
2. Tune the set to 69 MHz.
3. Adjust the RV1702 so that the reading of frequency counter connected to TP1702 becomes within 31.25 kHz ± 0.05 kHz. (VCO Adjustment)
4. Then record the reading of the level meter connected to TP1701
5. Set the modulation of FM RF SSG to AUDIO 31.25 kHz, 10 kHz deviation according to "Connection 2".
6. Tune the set to 69 MHz.
7. Set the CT1701 to be mechanical center.
8. Adjust the L1701 so that the reading of the level meter connected to TP1701 become maximum. Then adjust the CT1701 so that the reading of the level meter connected to TP1701 becomes maximum. (SUB CARRIER PEAK Adjustment)
9. Adjust the RV1701 so that the level at the moment becomes 14dB higher value than the level recorded in step 4. (SUB CARRIER LEVEL Adjustment)

[TCB BOARD] (Conductor Side)

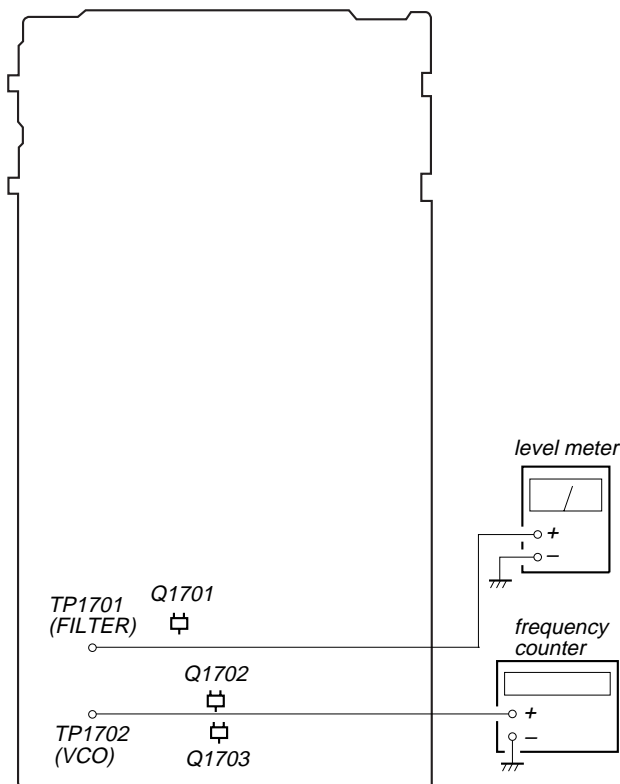

CD SECTION

Note:

1. CD Block is basically designed to operate without adjustment. Therefore, check each item in order given.
2. Use YEDS-18 disc (3-702-101-01) unless otherwise indicated.
3. Use an oscilloscope with more than 10 MΩ impedance.
4. Clean the object lens by an applicator with neutral detergent when the signal level is low than specified value with the following checks.

S Curve Check

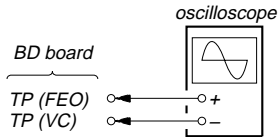

Procedure:

1. Connect oscilloscope to test point TP (FEO).
2. Connect between test point TP (FOK) and GND by lead wire.
3. Turn Power switch on.
4. Put disc (YEDS-18) in and turned Power switch on again and actuate the focus search. (Actuate the focus search when disc table is moving in and out.)
5. Check the oscilloscope waveform (S-curve) is symmetrical between A and B. And confirm peak to peak level within 3±1 Vp-p.

S-curve waveform

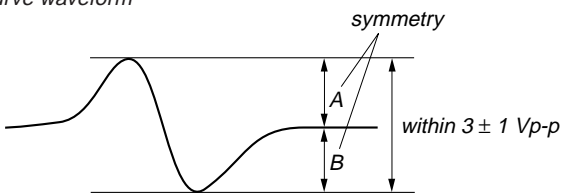

6. After check, remove the lead wire connected in step 2.

Note:

- Try to measure several times to make sure than the ratio of A : B or B : A is more than 10 : 7.
- Take sweep time as long as possible and light up the brightness to obtain best waveform.

RF Level Check

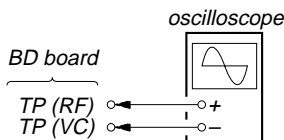

Procedure:

1. Connect oscilloscope to test point TP (RF) on BD board.
2. Turned Power switch on.
3. Put disc (YEDS-18) in and playback.
4. Confirm that oscilloscope waveform is clear and check RF signal level is correct or not.

Note: Clear RF signal waveform means that the shape “◇” can be clearly distinguished at the center of the waveform.

• FR signal

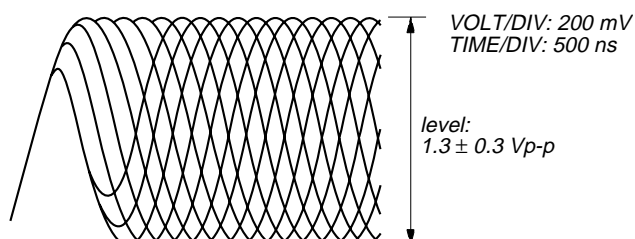

E-F Balance (Traverse) check (Without remote commander)

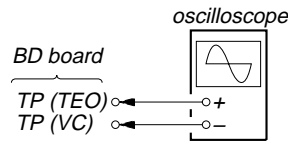

Procedure:

1. Connect oscilloscope to test point TP (TEO) on BD board.
2. Turned Power switch on. Press **FUNCTION** button to select CD.
3. Put disc (YEDS-18) in to play the number five track.
4. Press the **STOP** button, **ENTER/NEXT** button and **PAUSE** button simultaneously several times to fluorescent indicator tube display “SHUFFLE” is blink. (The sledding servo is turned OFF.)
5. Check the level B of the oscilloscope’s waveform and the A (DC voltage) of the center of the Traverse waveform. Confirm the following:

$$\frac{A}{B} \times 100 = \text{less than } \pm 7 (\%)$$

Traverse waveform

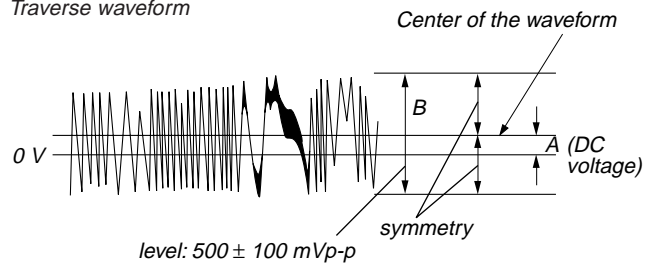

6. Press the **STOP** button, **ENTER/NEXT** button and **PAUSE** button simultaneously several times to fluorescent indicator tube display “SHUFFLE” is OFF. (The sledding servo is turned ON.) Confirm the C (DC voltage) is almost equal to the A (DC voltage) is step 5.

Traverse waveform

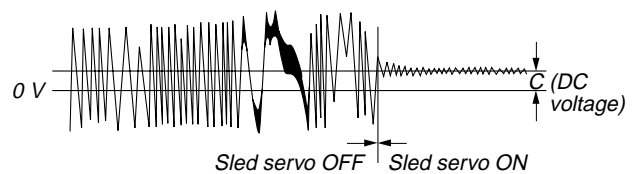

Adjustment Location:

[BD BOARD] (Conductor Side)

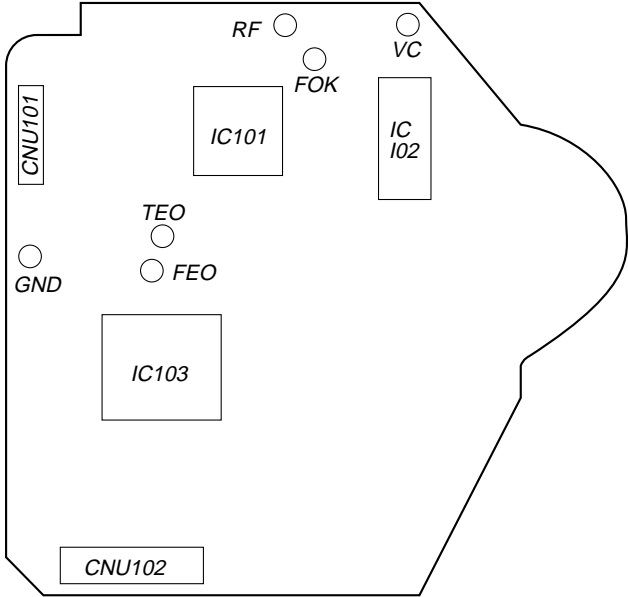

SECTION 7 DIAGRAMS

• Circuit Boards Location

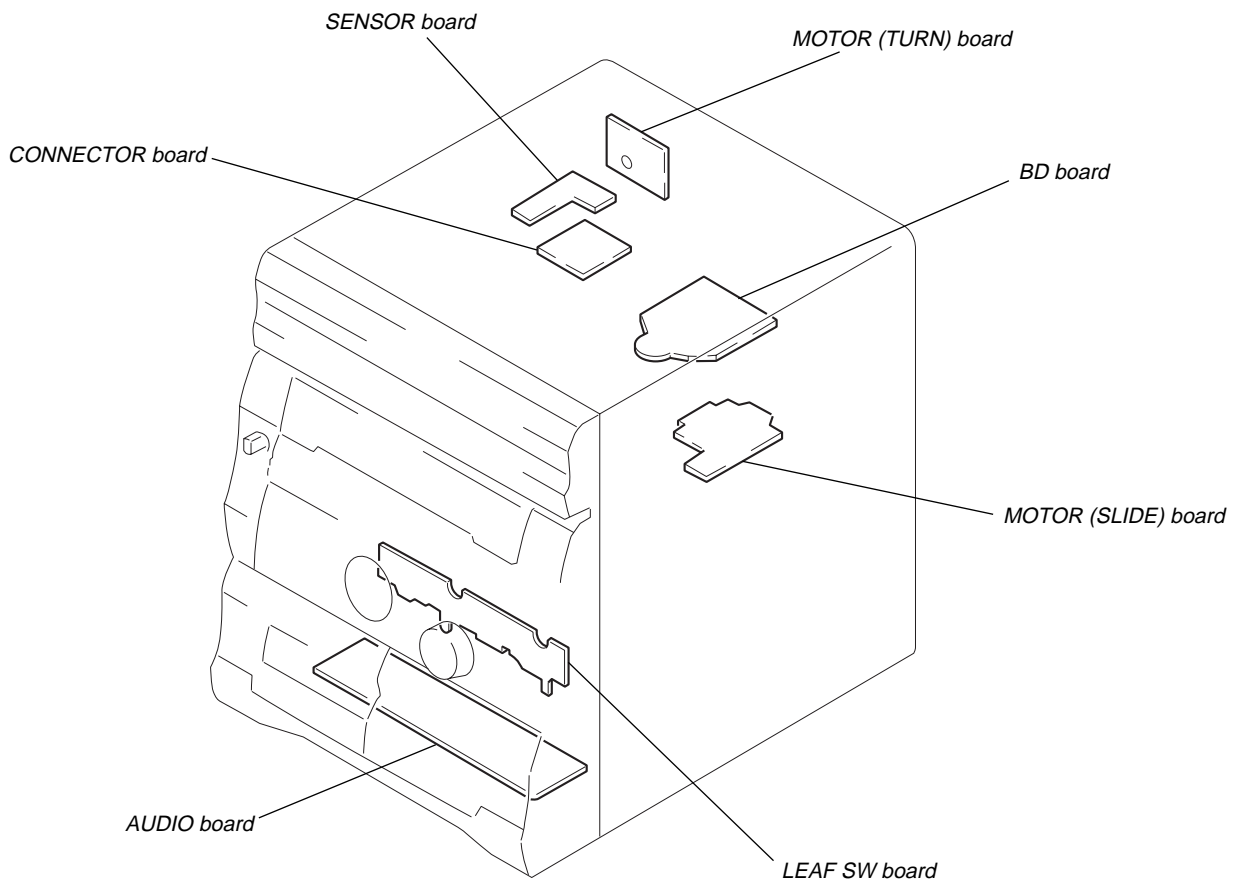
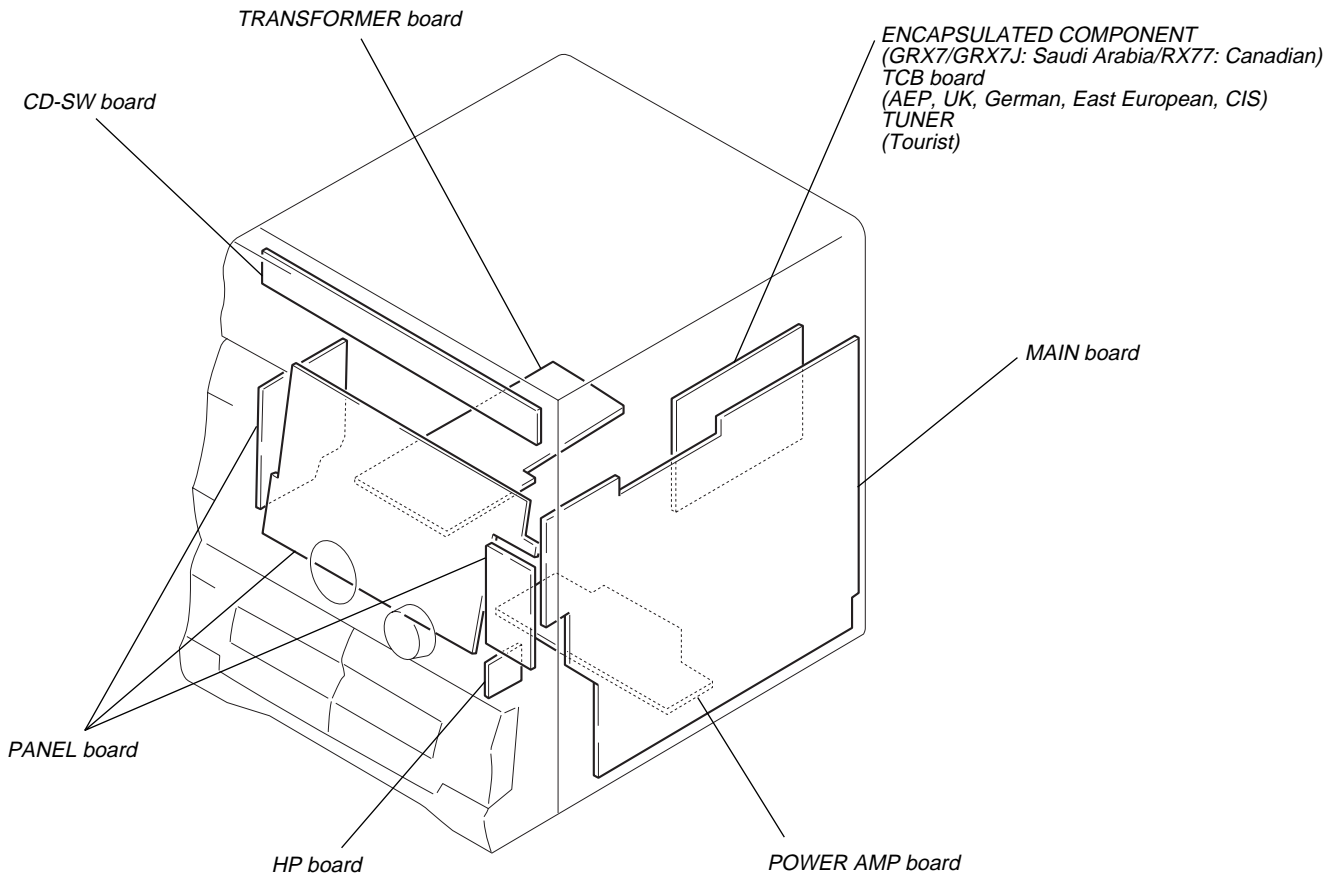

7-1. BLOCK DIAGRAM – TUNER Section (AEP, UK, German models only) –

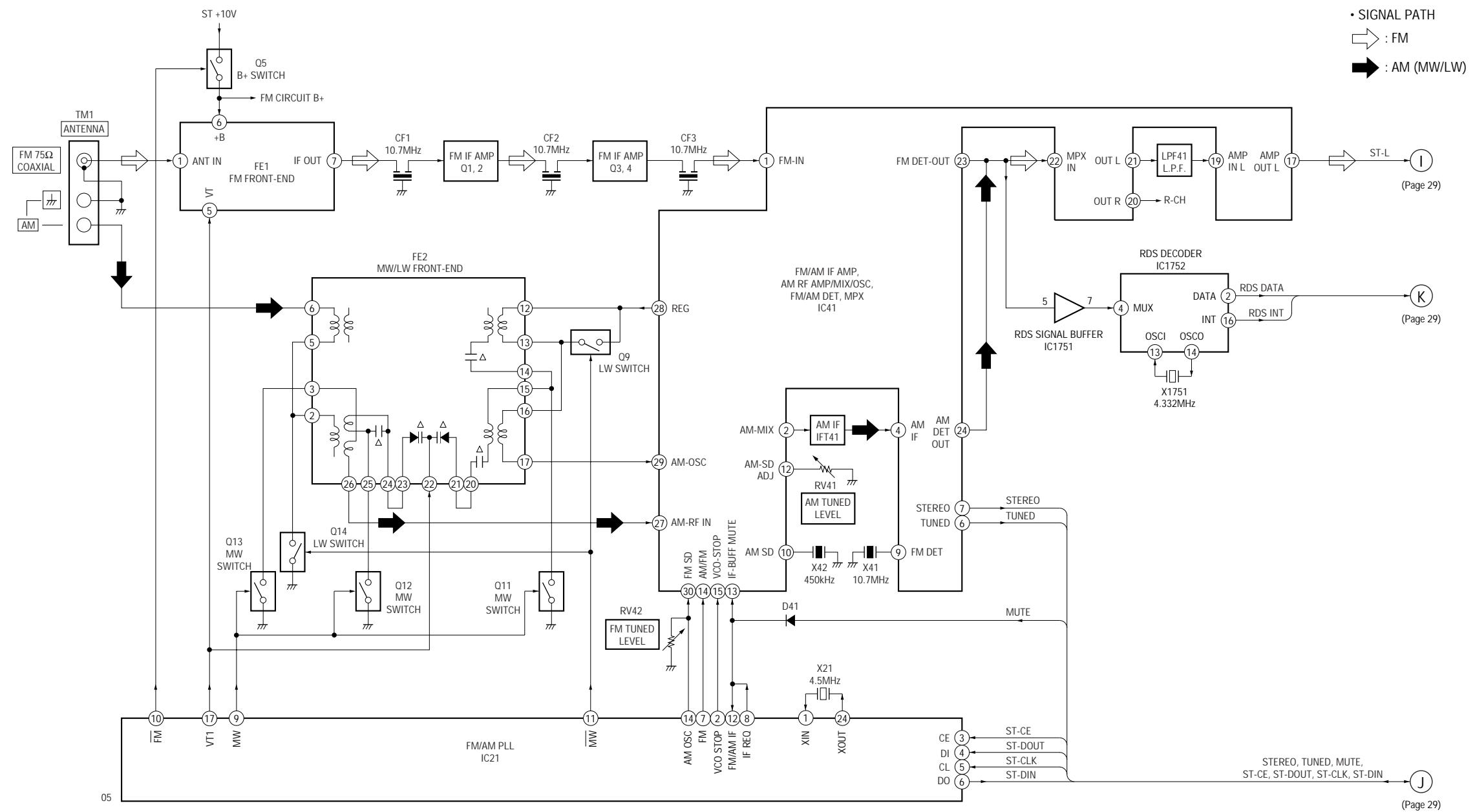

7-2. BLOCK DIAGRAM –TUNER Section (East European, CIS models only) –

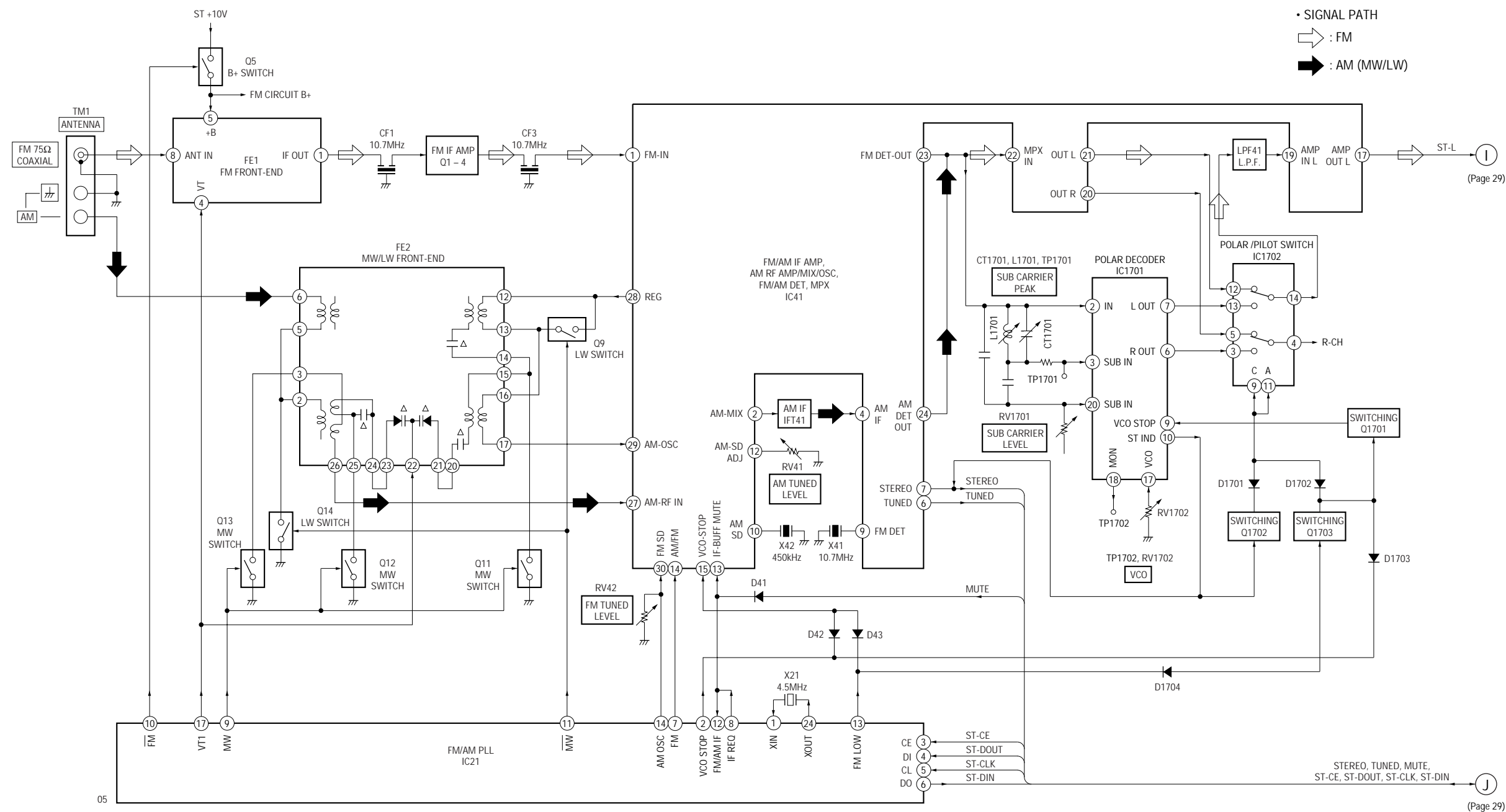

7-3. BLOCK DIAGRAM – CD MECHANISM DECK Section –

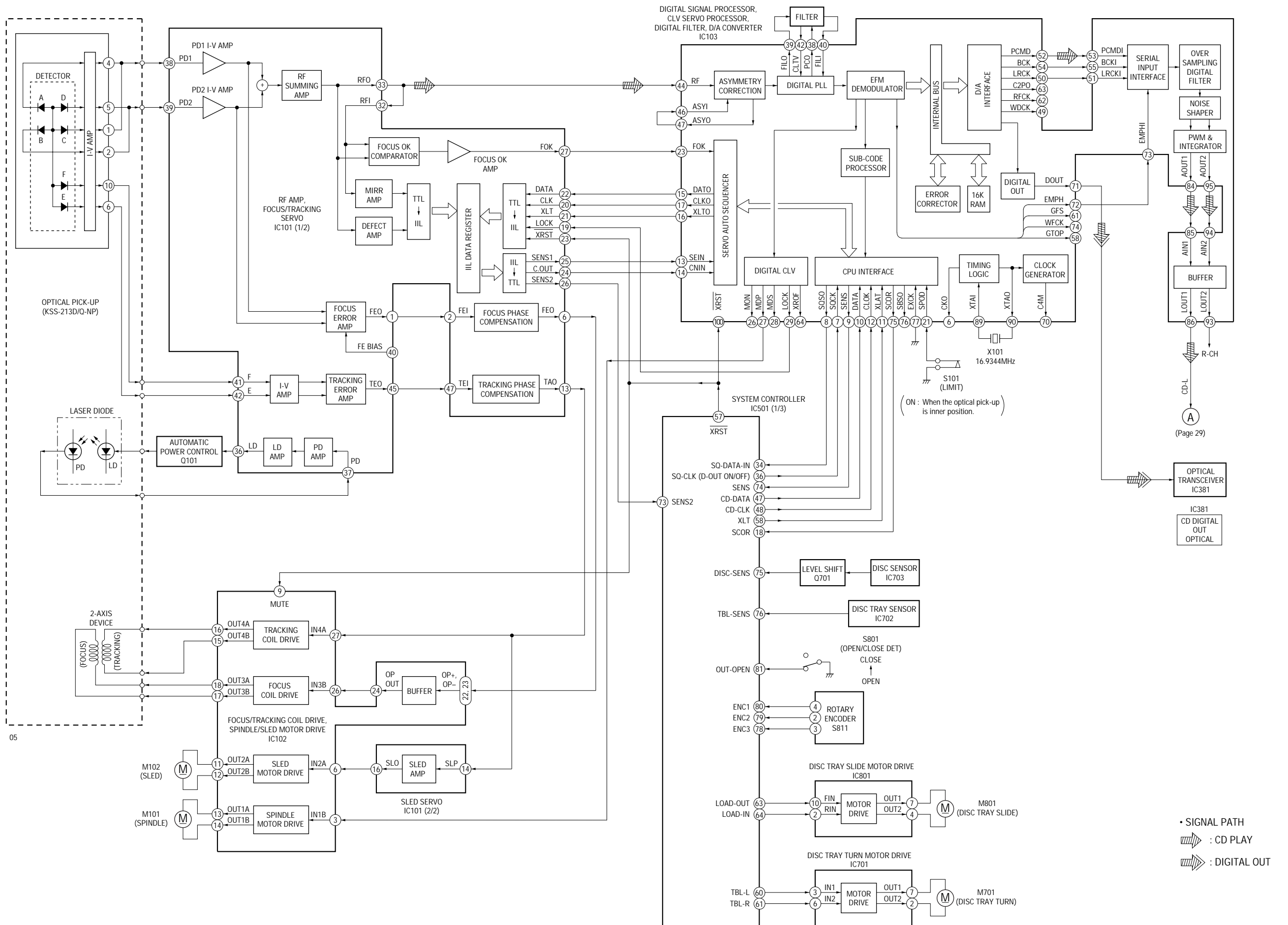

05

(Page 29)

7-4. BLOCK DIAGRAM –TAPE DECK Section –

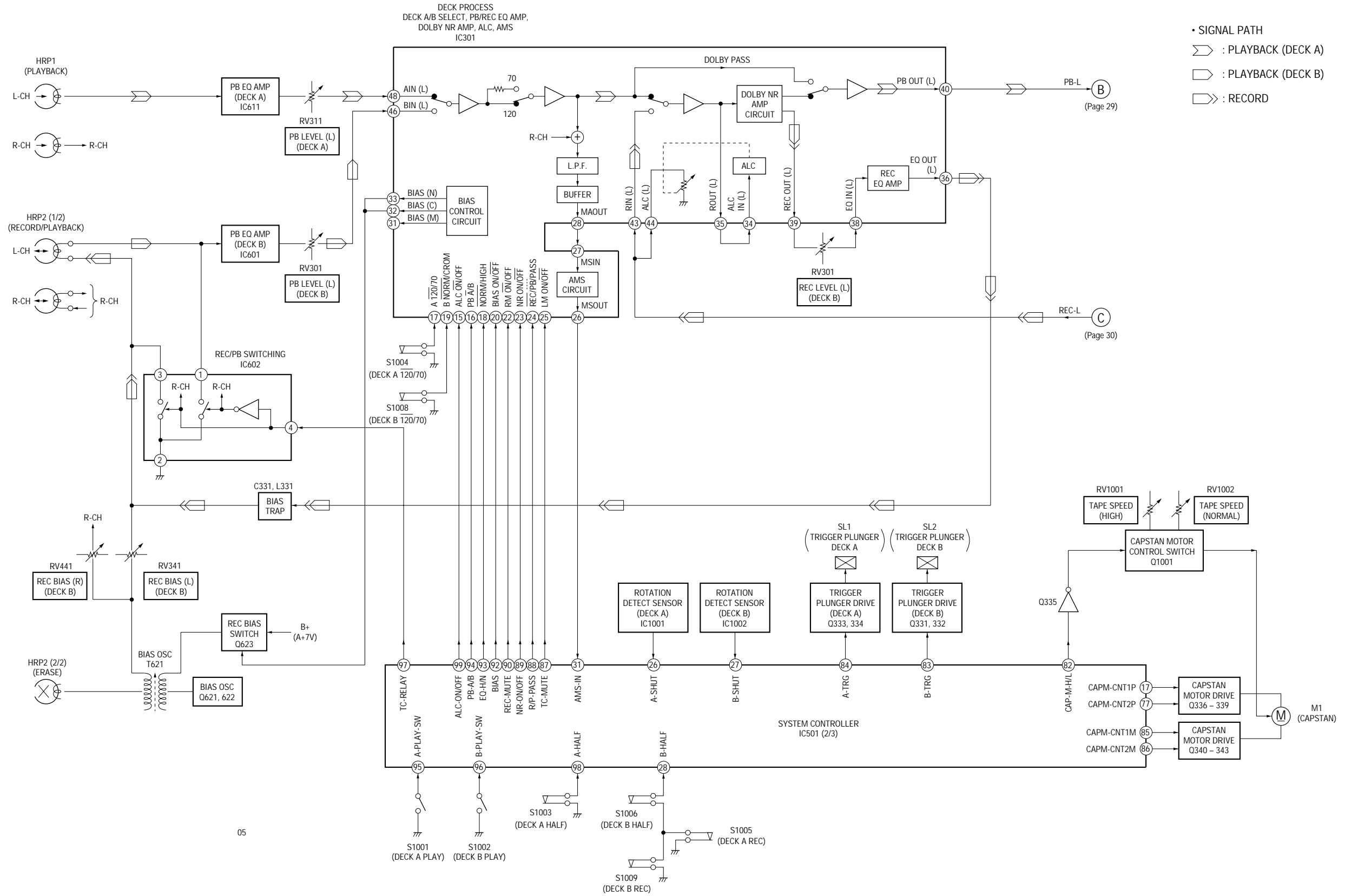

• SIGNAL PATH
 ≡ : PLAYBACK (DECK A)
 ≡ : PLAYBACK (DECK B)
 ≡ : RECORD

05

7-5. BLOCK DIAGRAM – MAIN Section –

- SIGNAL PATH
- : CD PLAY
- : TUNER (FM/AM)
- : TAPE PLAY
- : MIC INPUT
- : RECORD

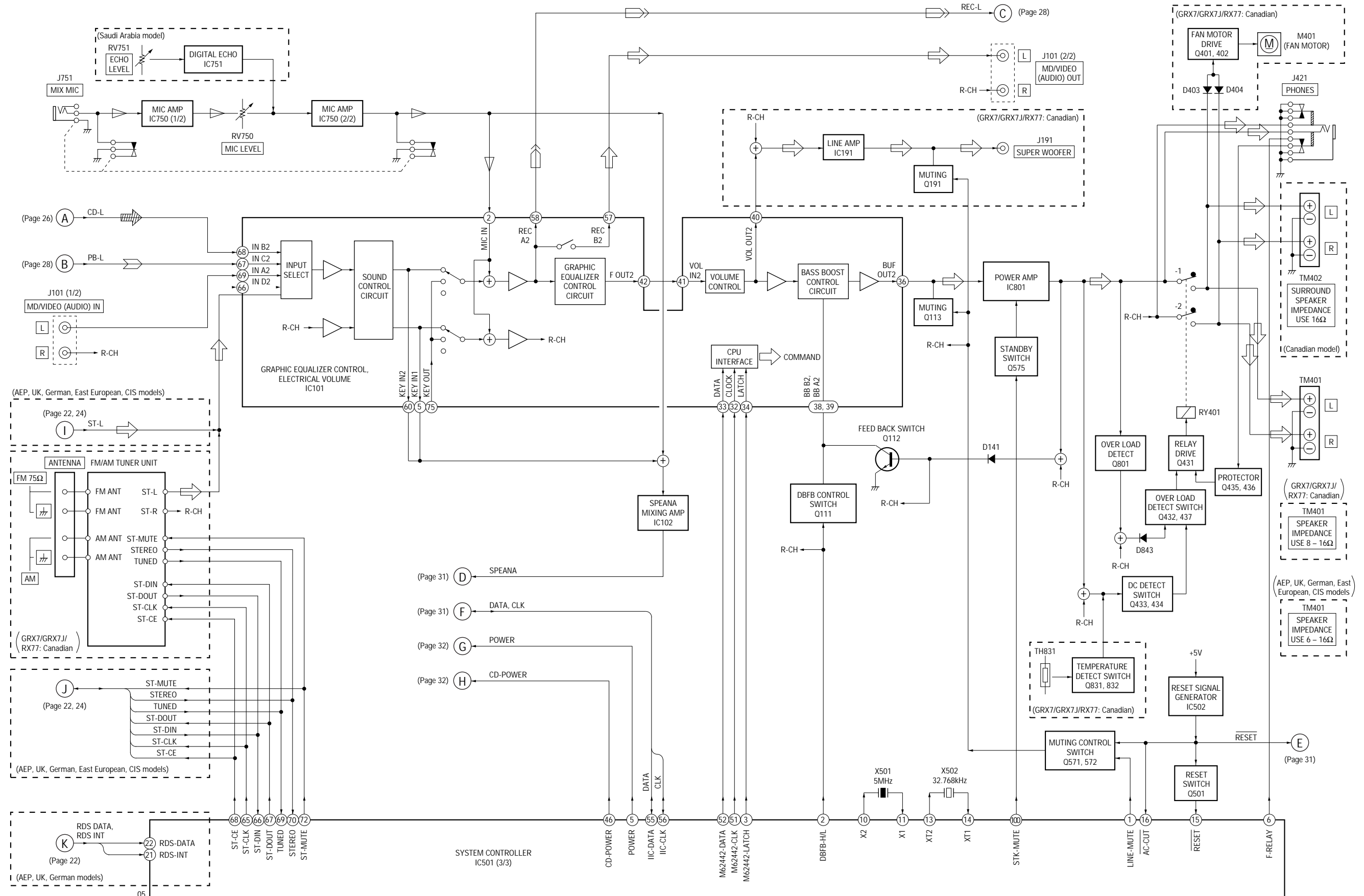

7-6. BLOCK DIAGRAM – DISPLAY/KEY CONTROL/POWER SUPPLY Section –

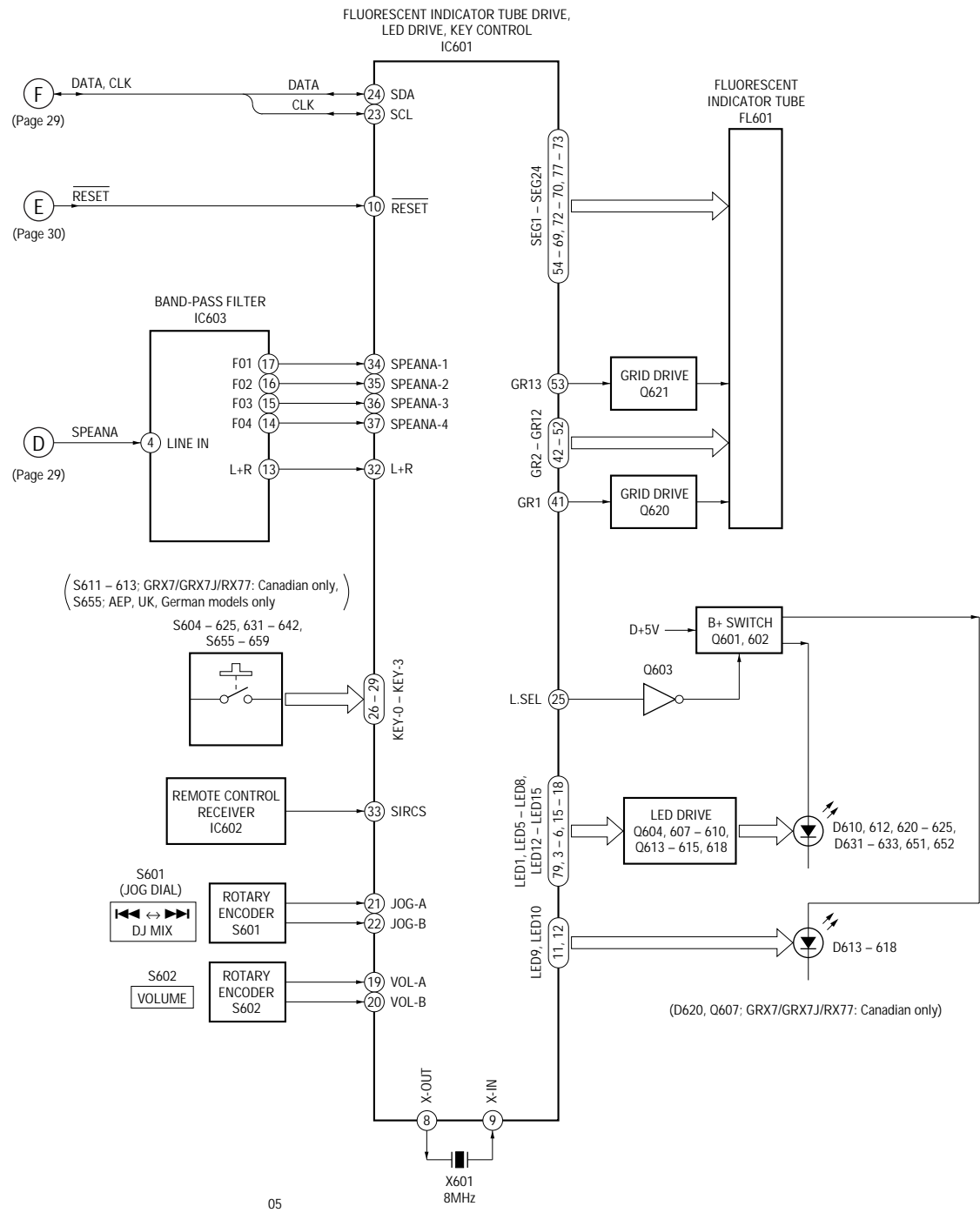

05

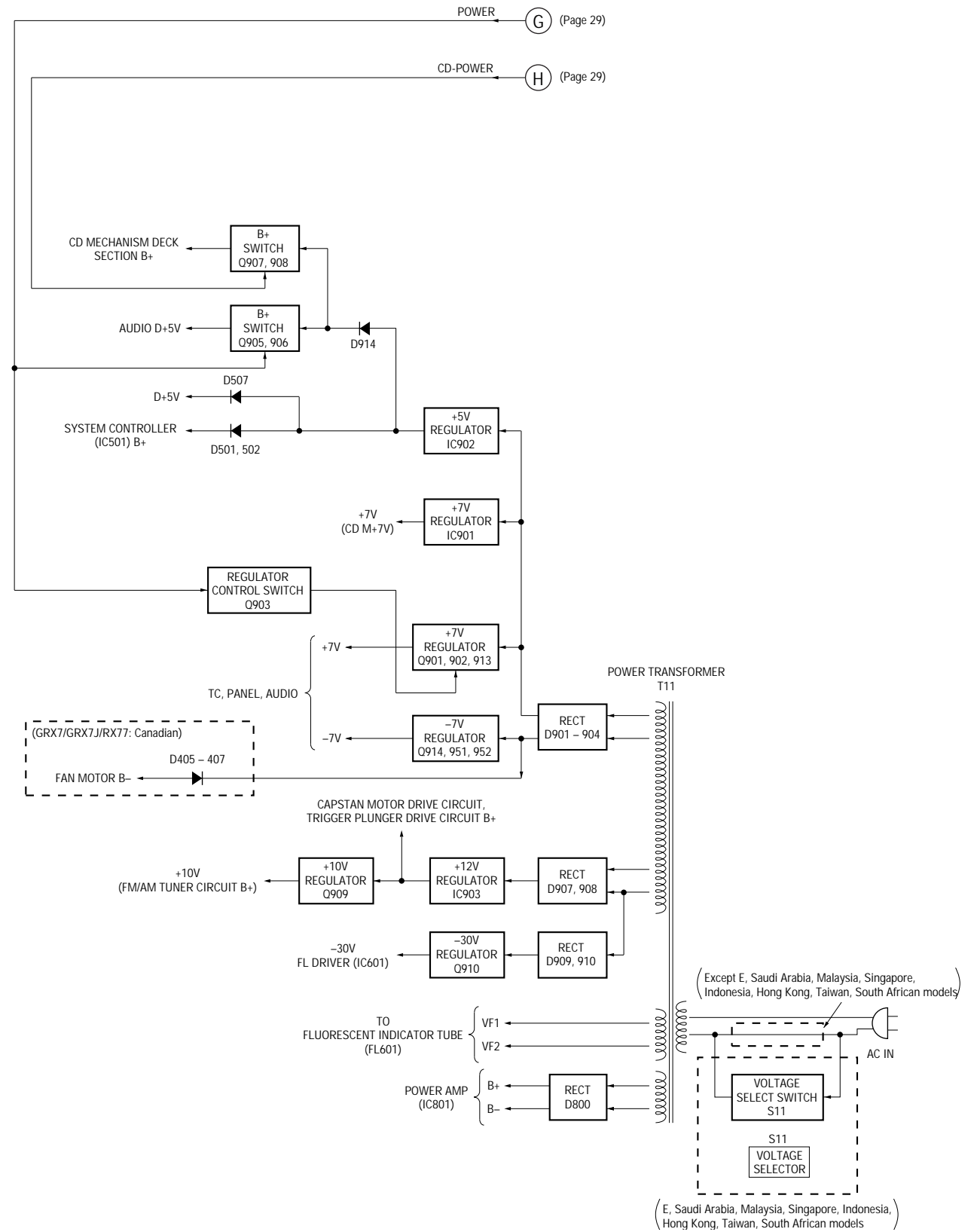

THIS NOTE IS COMMON FOR PRINTED WIRING BOARDS AND SCHEMATIC DIAGRAMS.
(In addition to this, the necessary note is printed in each block.)

Note on Schematic Diagram:

- All capacitors are in μF unless otherwise noted. pF : μF 50 WV or less are not indicated except for electrolytics and tantalums.
- All resistors are in Ω and $1/4\text{ W}$ or less unless otherwise specified.
- Δ : internal component.
- \square : panel designation.

Note:

The components identified by mark Δ or dotted line with mark Δ are critical for safety. Replace only with part number specified.

Note:

Les composants identifiés par une marque Δ sont critiques pour la sécurité. Ne les remplacer que par une pièce portant le numéro spécifié.

Note on Printed Wiring Boards:

- \circ : parts extracted from the component side.
- \blacksquare : parts mounted on the conductor side.
- \circ : Through hole.
- \square : Pattern from the side which enables seeing. (The other layers' patterns are not indicated.)

Caution:

Pattern face side: Parts on the pattern face side seen from the pattern face are indicated.
Parts face side: Parts on the parts face side seen from the parts face are indicated.

- Indication of transistor.

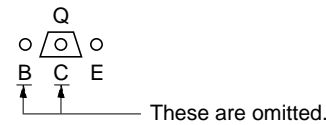
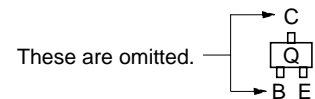

- $\text{B}+$: B+ Line.
- $\text{B}-$: B- Line.
- \square : adjustment for repair.
- Voltages and waveforms are dc with respect to ground under no-signal (detuned) conditions.
- Voltages are taken with a VOM (Input impedance 10 M Ω). Voltage variations may be noted due to normal production tolerances.
- Waveforms are taken with a oscilloscope. Voltage variations may be noted due to normal production tolerances.
- Circled numbers refer to waveforms.
- Signal path.
 - \rightarrow : FM
 - \rightarrow : AM
 - \rightarrow : PB (DECK A)
 - \rightarrow : PB (DECK B)
 - \rightarrow : REC (DECK B)
 - \rightarrow : CD
 - \rightarrow : digital out
 - \rightarrow : Mic in
- Abbreviation
 - AUS : Australian model.
 - CND : Canadian model.
 - E2 : 120 V AC Area in E model.
 - E3 : 240 V AC Area in E model.
 - EA3 : Saudi Arabia model.
 - EA4 : Israel model.
 - EE : East European model.
 - G : German model.
 - HK : Hong Kong model.
 - IA : Indonesian model.
 - JE : Tourist model.
 - MX : Mexican model.
 - MY : Malaysia model.
 - SAF : South African model.
 - SP : Singapore model.
 - TH : Thai model.
 - TW : Taiwan model.

• Waveforms
– TUNER Section –
(AEP, UK, German)

① IC21 ②④ (XOUT)

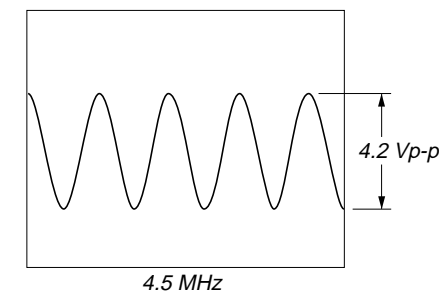

② IC1752 ①④ (OEC0)

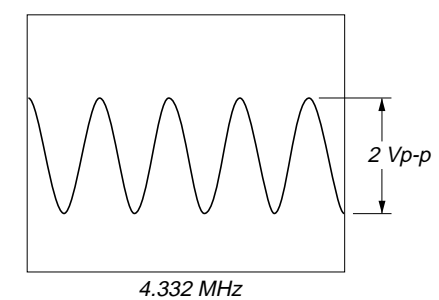

– TUNER Section –
(East European, CIS)

① IC21 ②④ (XOUT)

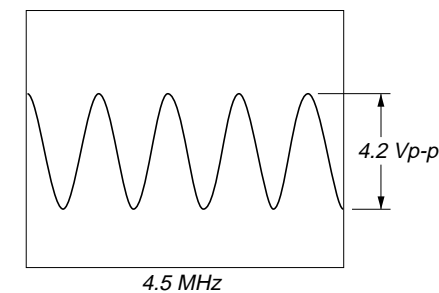

– CD Section –

① IC101 ③③ (RF O) (PLAY MODE)

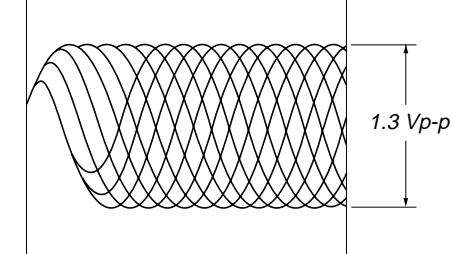

② IC101 ② (FEI) (PLAY MODE)

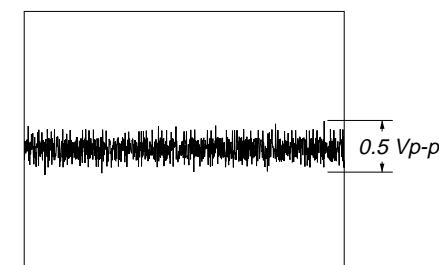

③ IC101 ④⑦ (TEI) (PLAY MODE)

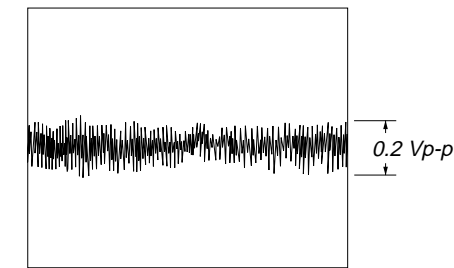

④ IC103 ②⑦ (MDP)

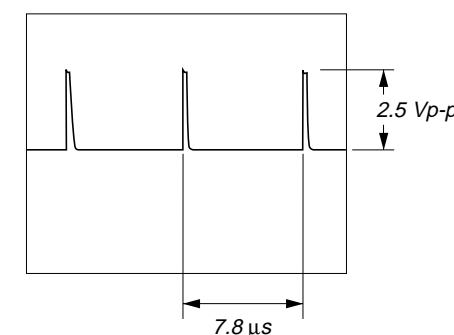

⑤ IC103 ⑥⑩ (XPCK)

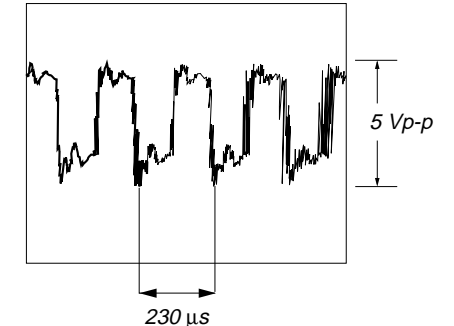

⑥ IC103 ⑥⑩ (RFCK)

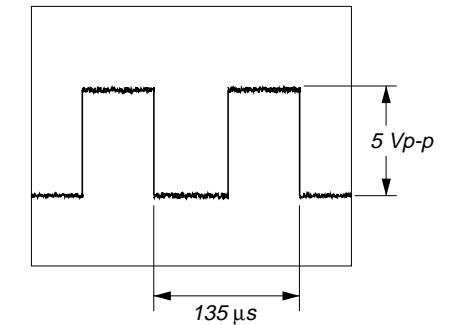

⑦ IC103 ⑦⑩ (WFCK)

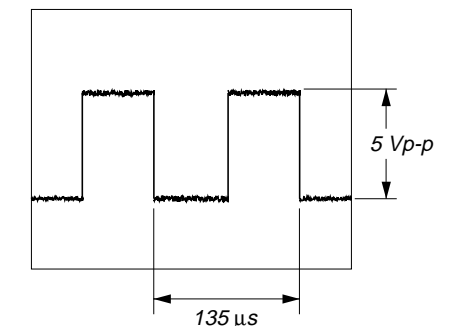

⑧ IC103 ⑥⑩ (XTAI)

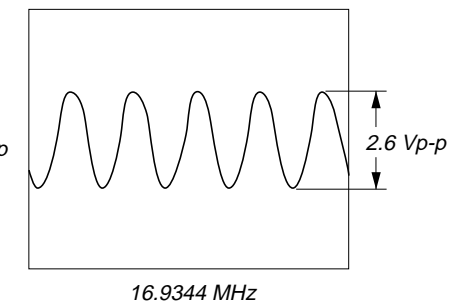

– MAIN Section –

① IC501 ①① (X1)

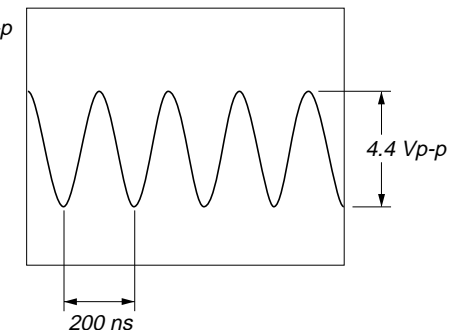

② IC501 ①④ (XT1)

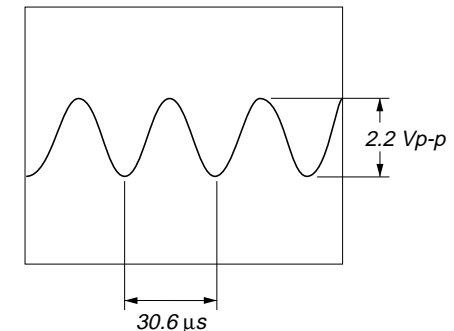

– PANEL Section –

③ IC601 ⑨ (X-IN)

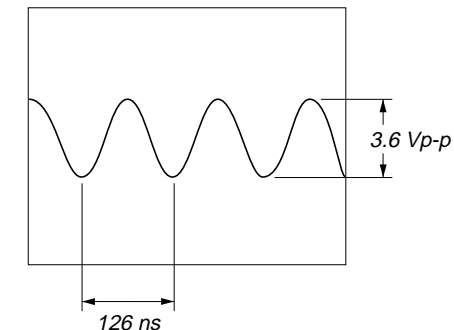

7-7. SCHEMATIC DIAGRAM –TUNER Section (AEP, UK, German models only) –

- See page 33 for Note on Schematic Diagram.
- See page 34 for Waveforms. • See page 77 and 78 for IC Block Diagrams.

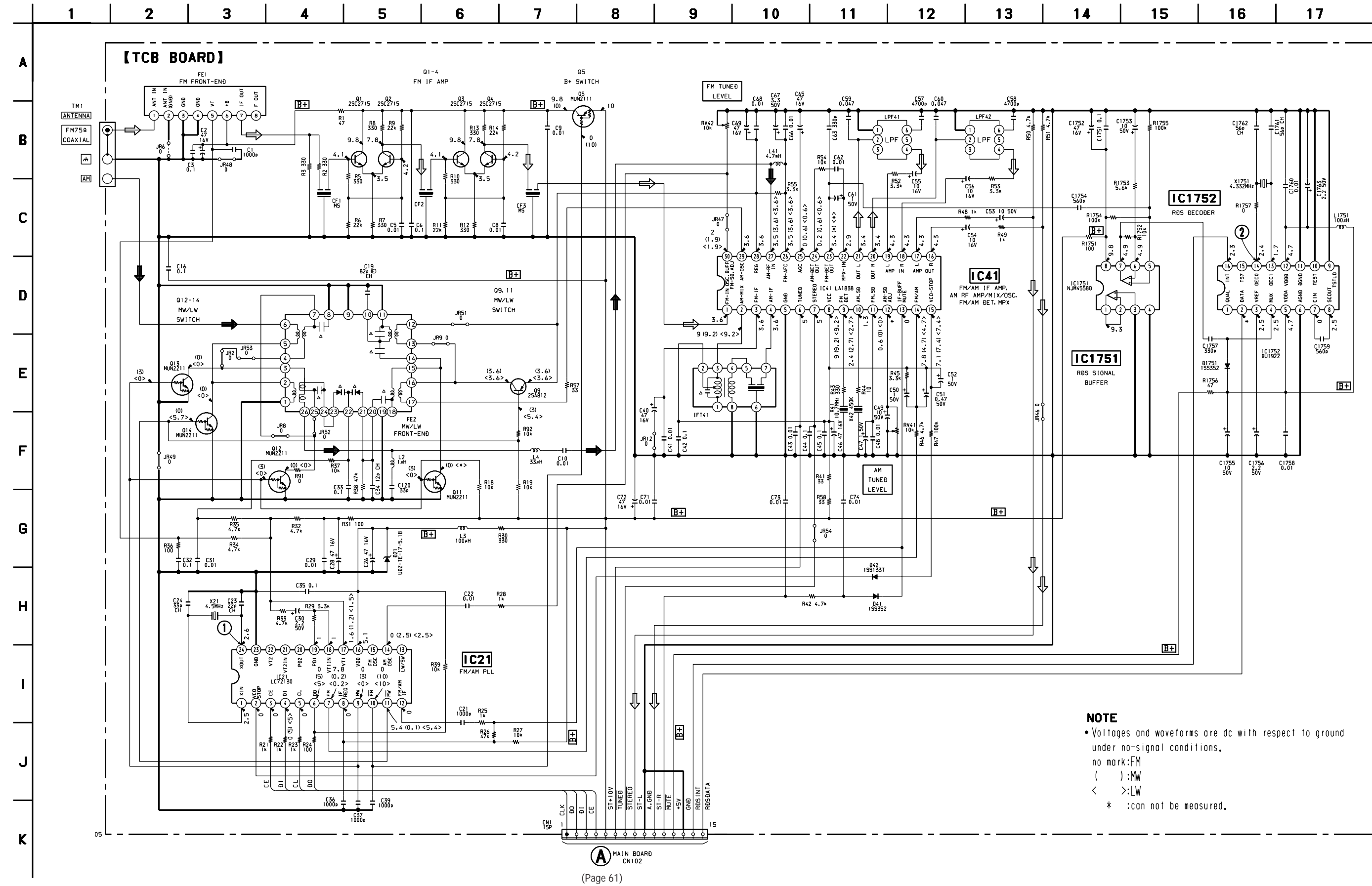

NOTE

- Voltages and waveforms are dc with respect to ground under no-signal conditions.
- no mark:FM
- ():MW
- < >:LW
- * :can not be measured.

7-8. PRINTED WIRING BOARD – TUNER Section (AEP, UK, German models only) –

• See page 20 for Circuit Boards Location. • See page 33 for Note on Printed Wiring Board.

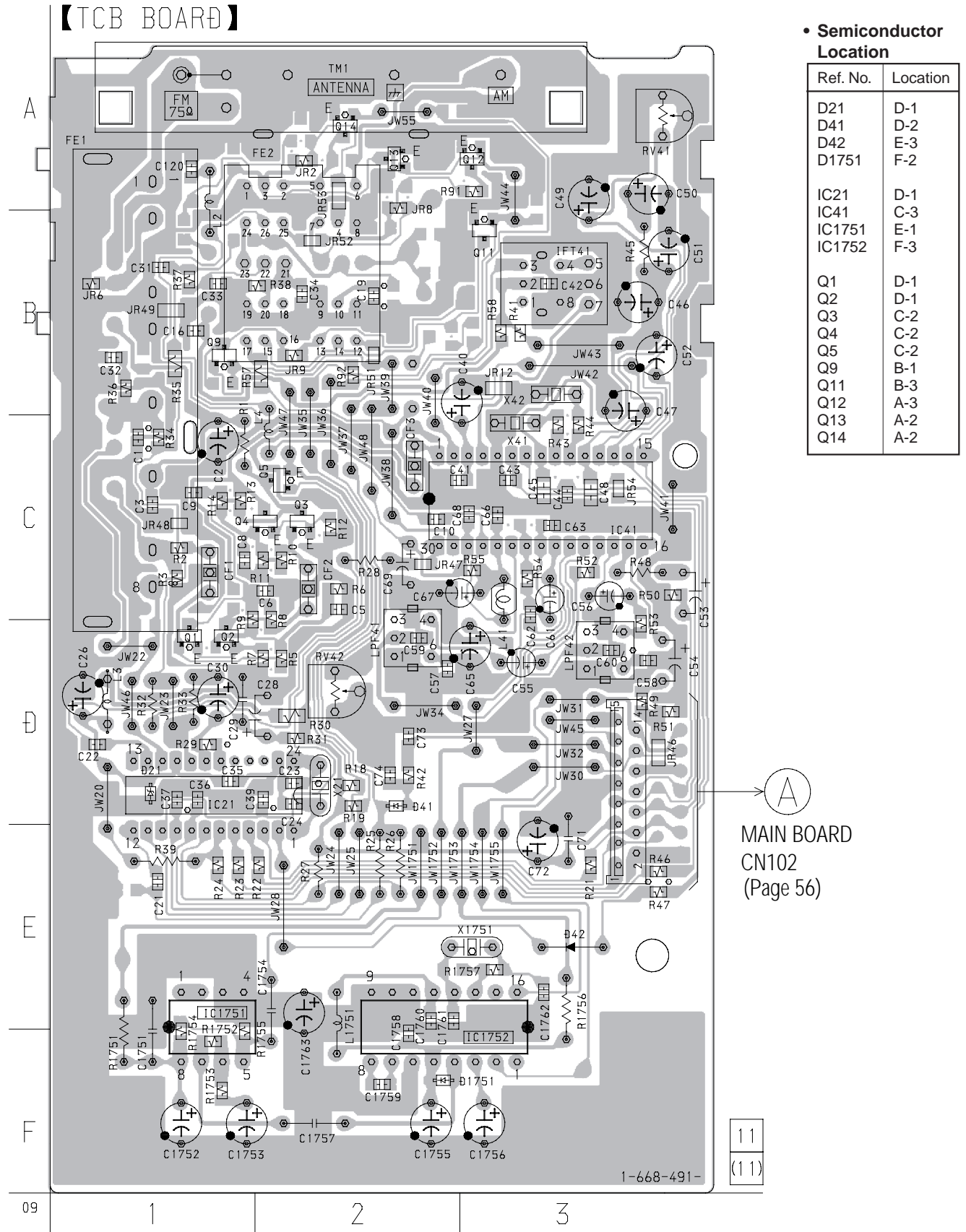

7-9. PRINTED WIRING BOARD – TUNER Section (East European, CIS models only) –

• See page 20 for Circuit Boards Location. • See page 33 for Note on Printed Wiring Board.

【TCB BOARD】

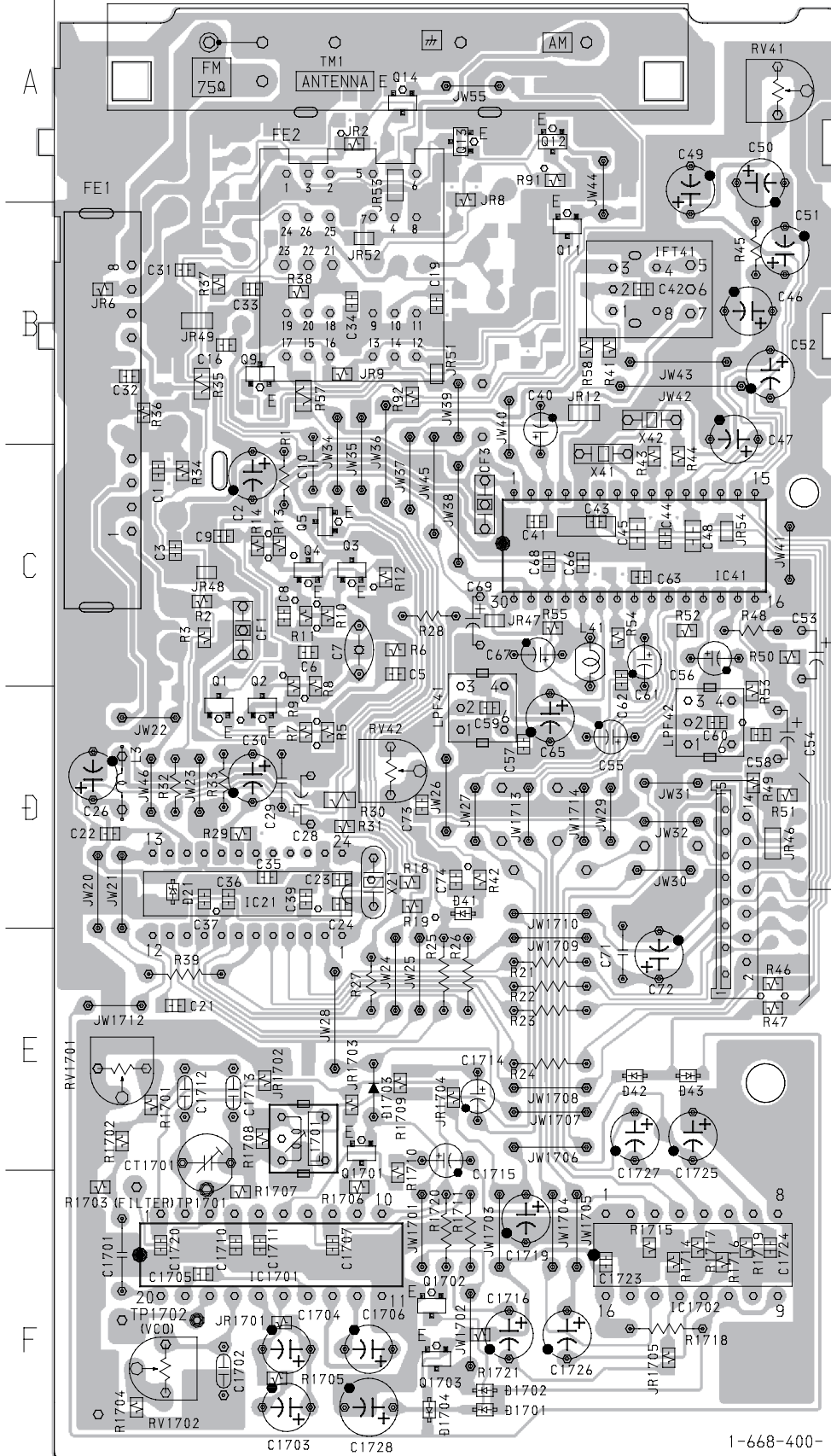

• Semiconductor Location

Ref. No.	Location
D1	D-1
D41	D-2
D42	E-3
D43	E-3
D1701	F-2
D1702	F-2
D1703	E-2
D1704	F-2
IC21	D-1
IC41	C-3
IC1701	F-1
IC1702	F-3
Q1	D-1
Q2	D-2
Q3	C-2
Q4	C-2
Q5	C-2
Q9	B-1
Q11	B-3
Q12	A-3
Q13	A-2
Q14	A-2
Q1701	E-2
Q1702	F-2
Q1703	F-2

Ⓐ
MAIN BOARD
CN102
(Page 56)

11
(11)

1-668-400-

7-10. SCHEMATIC DIAGRAM - TUNER Section (East European, CIS models only) -

• See page 33 for Note on Schematic Diagram. • See page 34 for Waveforms. • See page 77 and 78 for IC Block Diagrams.

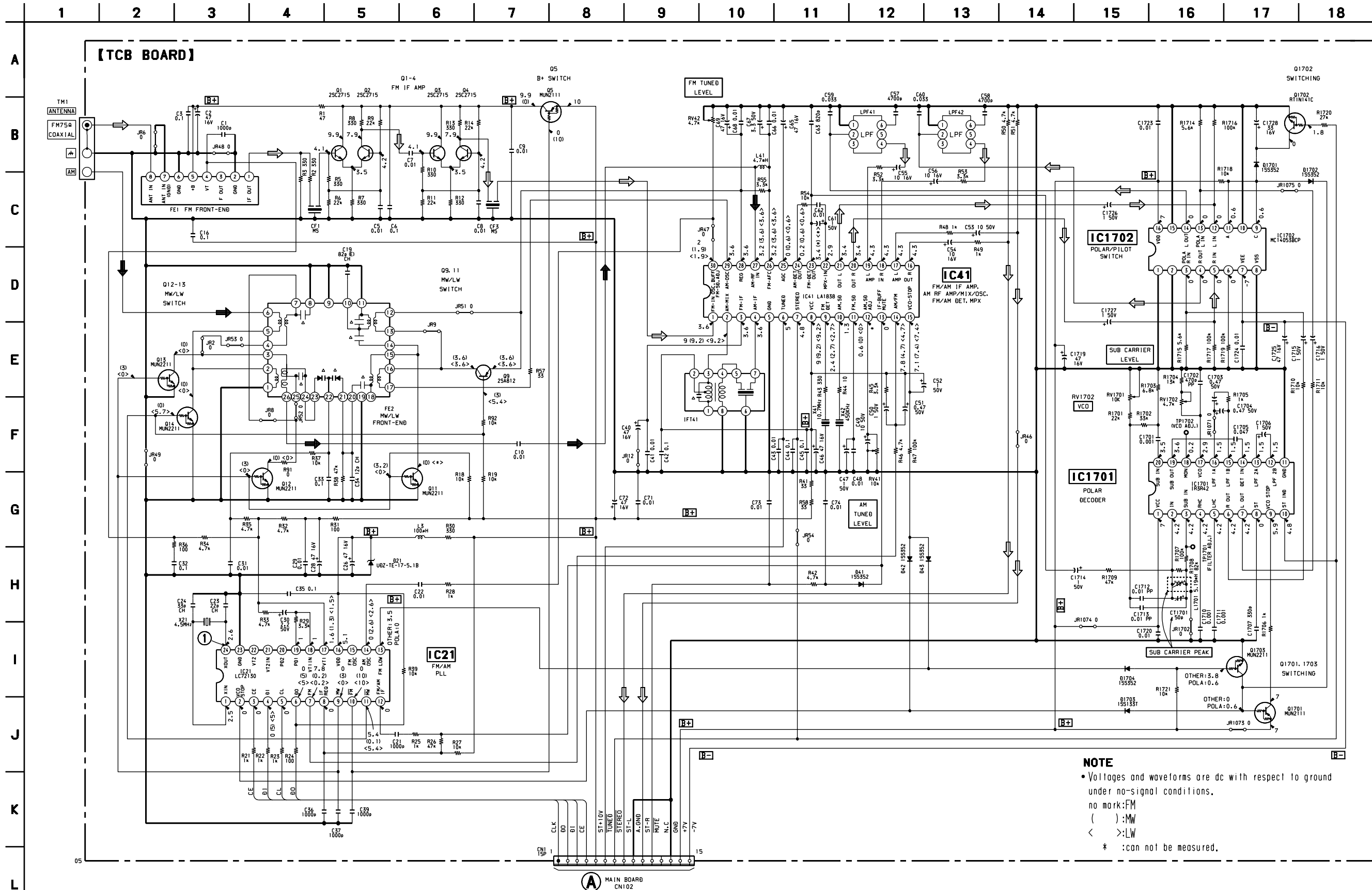

NOTE
 • Voltages and waveforms are dc with respect to ground under no-signal conditions.
 no mark: FM
 (): MW
 < >: LW
 * : can not be measured.

MAIN BOARD
 CNI02

7-11. PRINTED WIRING BOARD – CD Section –

• See page 20 for Circuit Boards Location. • See page 33 for Note on Printed Wiring Board.

• Semiconductor Location

Ref. No.	Location
IC101	C-5
IC102	B-5
IC103	C-6
Q101	C-3

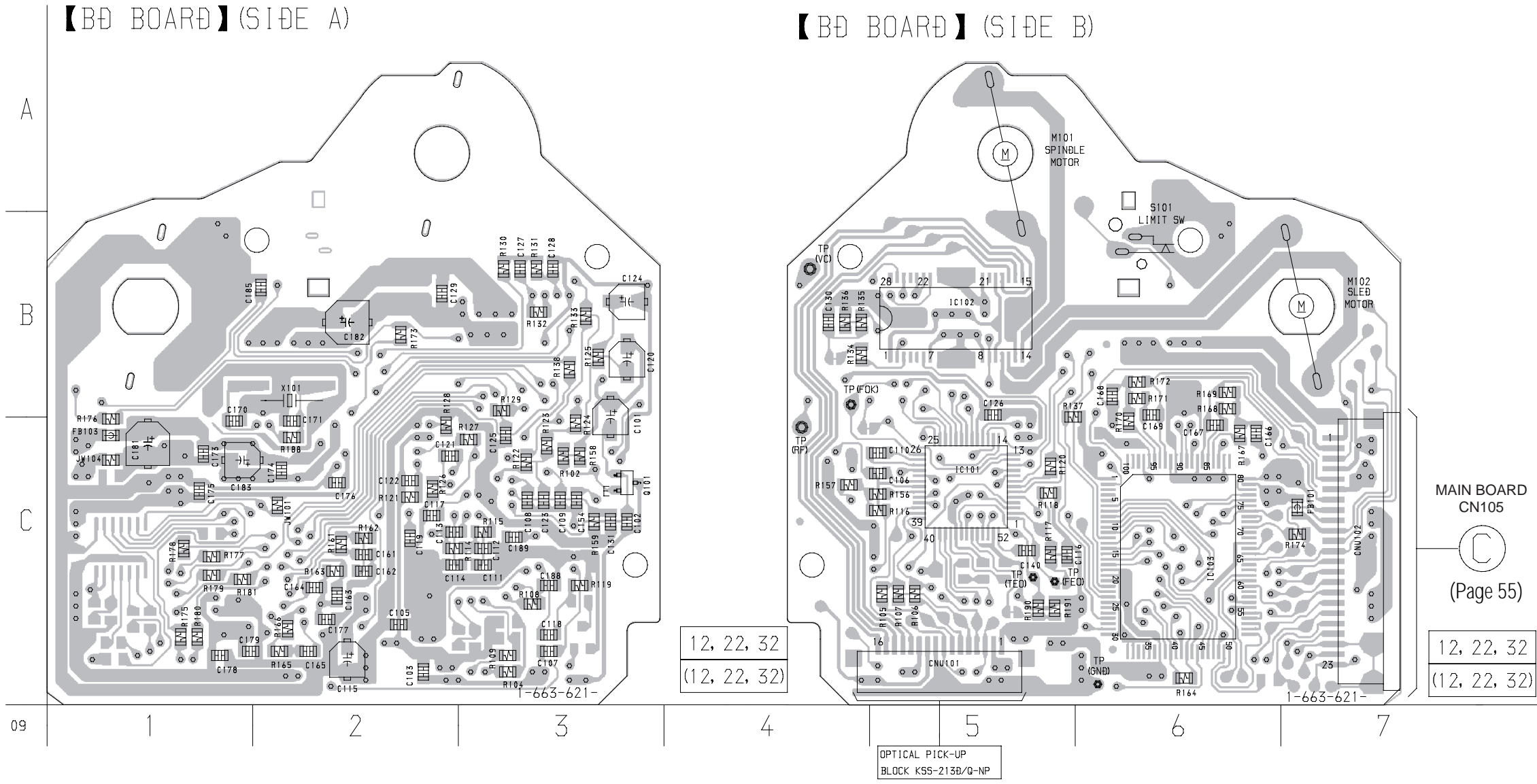

7-12. SCHEMATIC DIAGRAM – CD Section – • See page 33 for Note on Schematic Diagram. • See page 34 for Waveforms. • See page 79 and 80 for IC Block Diagrams.

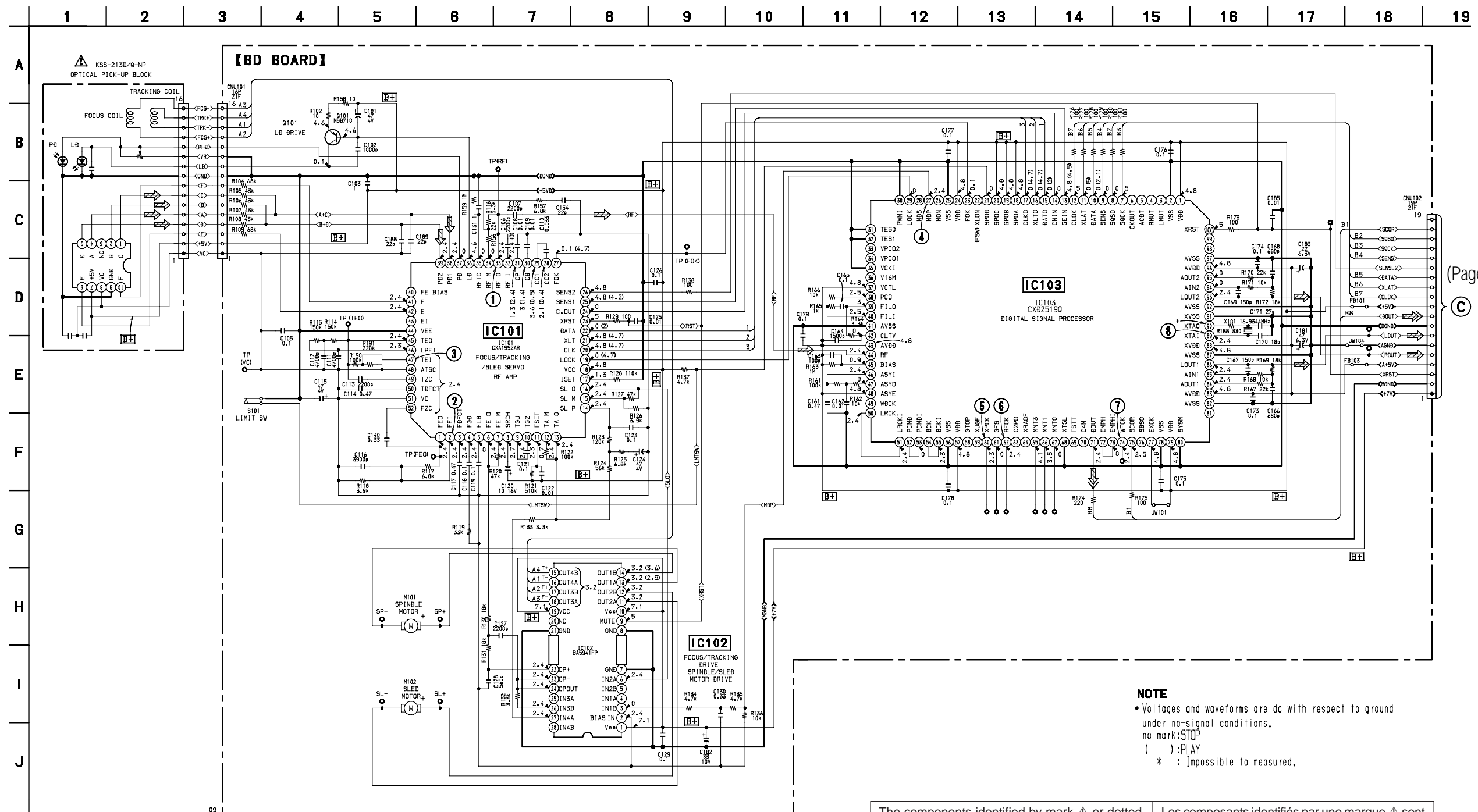

(Page 57)
 (C) MAIN BOARD
 CN105

NOTE
 • Voltages and waveforms are dc with respect to ground under no-signal conditions.
 no mark: STOP
 (): PLAY
 * : Impossible to measured.

The components identified by mark Δ or dotted line with mark Δ are critical for safety. Replace only with part number specified.

Les composants identifiés par une marque Δ sont critiques pour la sécurité. Ne les remplacer que par une pièce portant le numéro spécifié.

7-13. PRINTED WIRING BOARDS – CD MOTOR Section –

• See page 20 for Circuit Boards Location. • See page 33 for Note on Printed Wiring Boards.

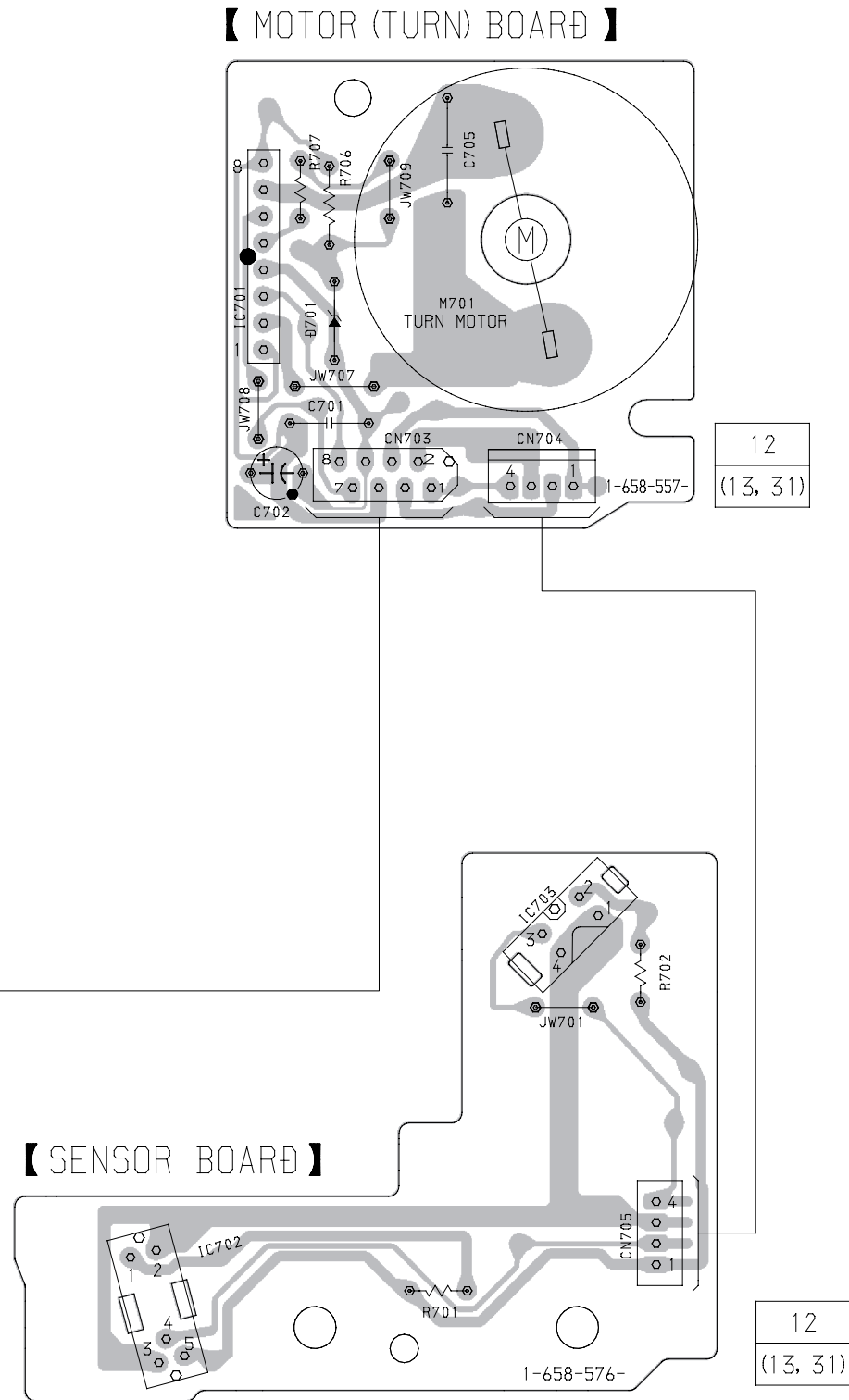
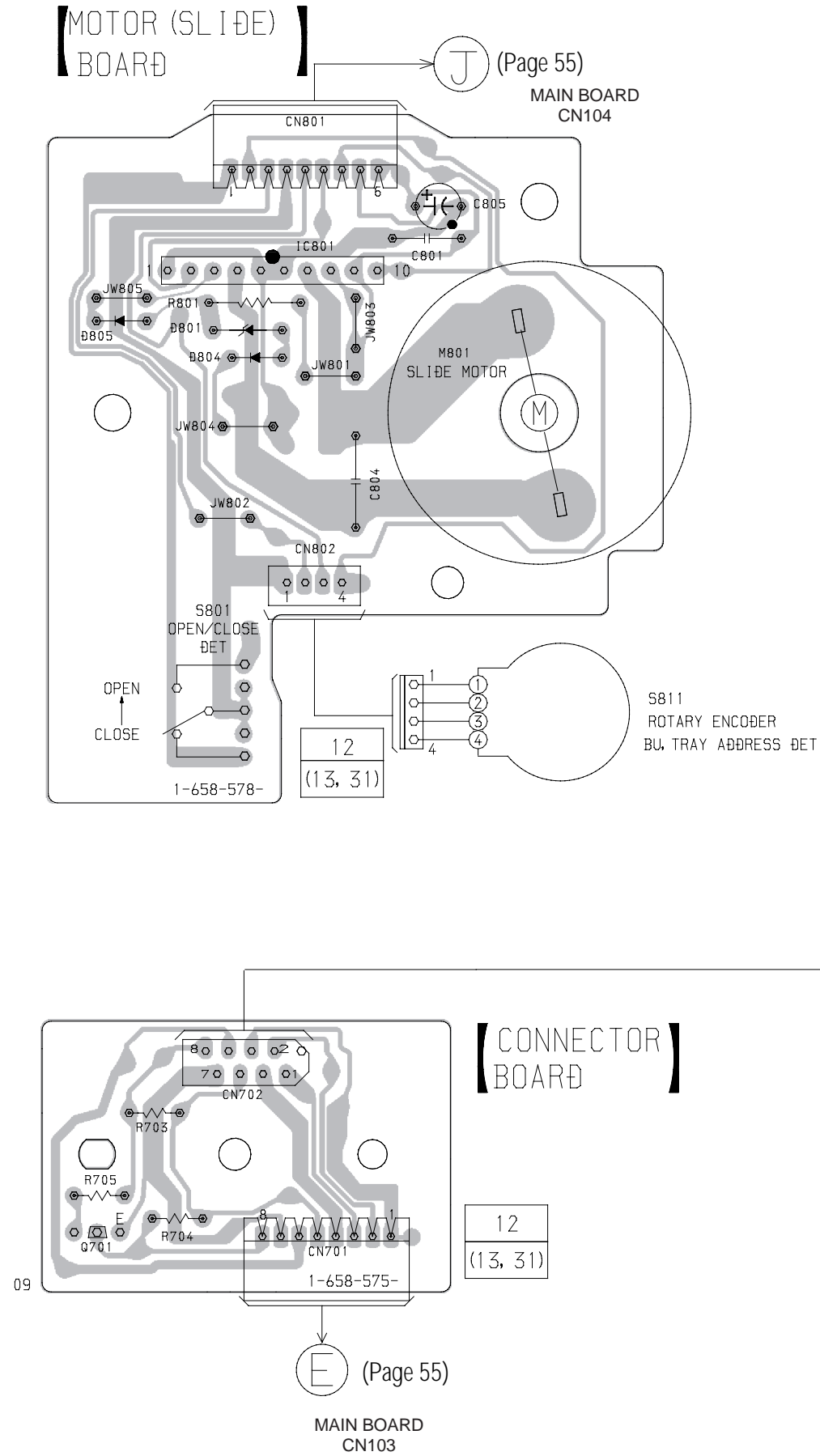

7-14. SCHEMATIC DIAGRAM – CD MOTOR Section –

- See page 33 for Note on Schematic Diagram.
- See page 81 for IC Block Diagrams.

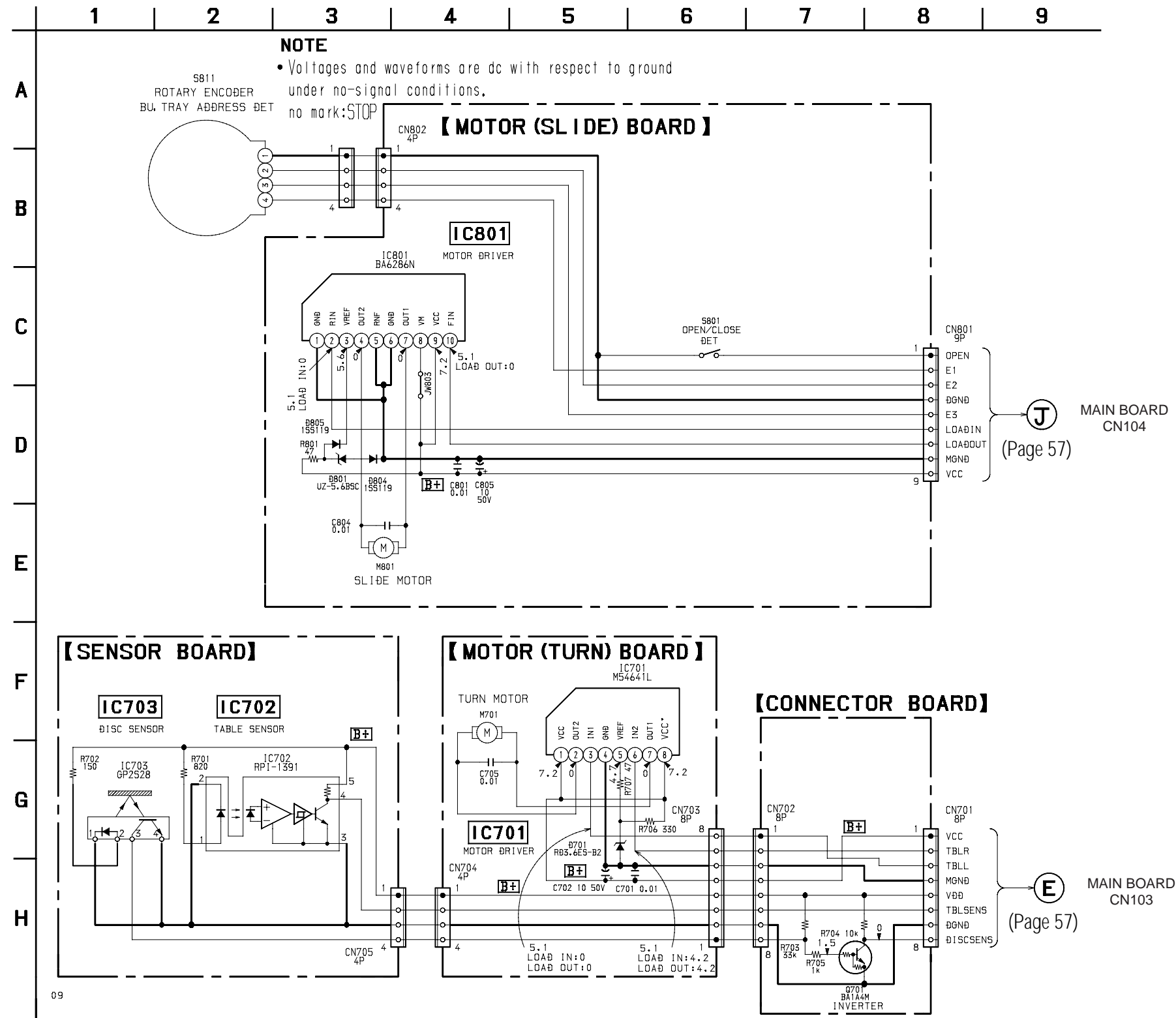

7-15. PRINTED WIRING BOARD – TAPE DECK Section –

• See page 20 for Circuit Boards Location. • See page 33 for Note on Printed Wiring Boards.

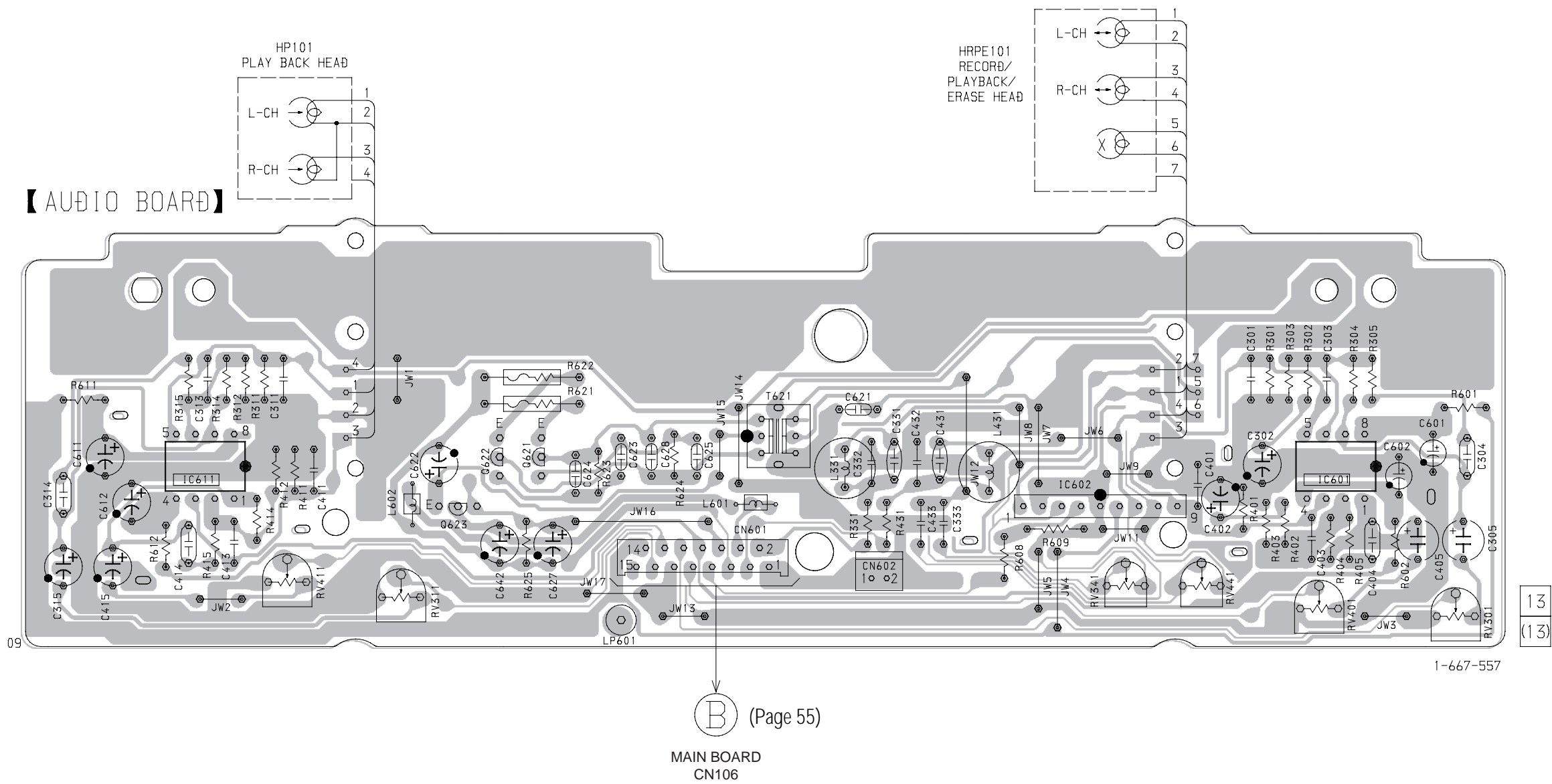

7-16. SCHEMATIC DIAGRAM – TAPE DECK Section –

- See page 33 for Note on Schematic Diagram.
- See page 81 for IC Block Diagram.

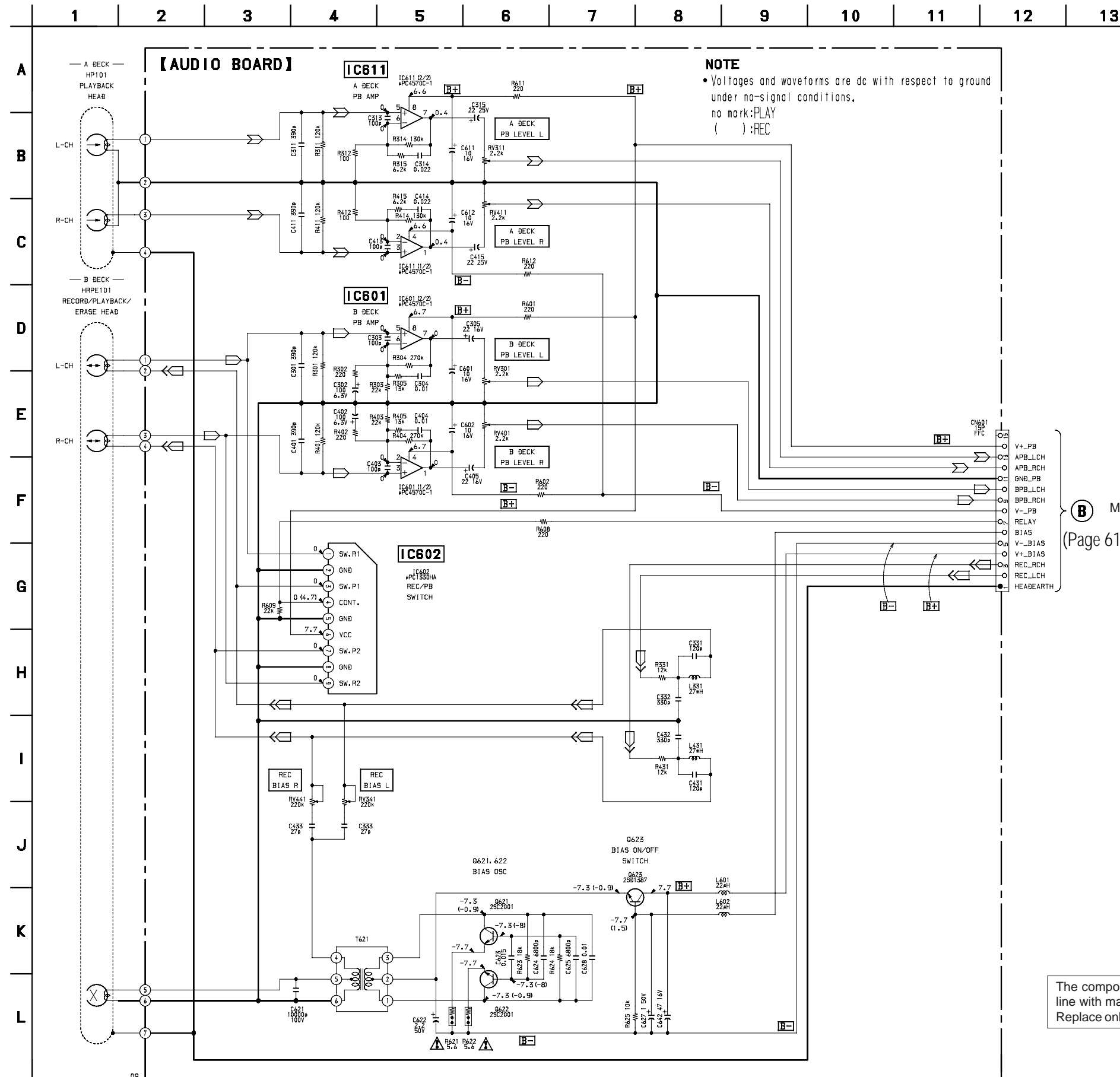

The components identified by mark \triangle or dotted line with mark \triangle are critical for safety. Replace only with part number specified.

Les composants identifiés par une marque \triangle sont critiques pour la sécurité. Ne les remplacer que par une pièce portant le numéro spécifié.

HCD-GRX7/GRX7J/R700/RX77/RX77S

7-17. PRINTED WIRING BOARD – LEAF SW Section – • See page 20 for Circuit Boards Location. • See page 33 for Note on Printed Wiring Boards.

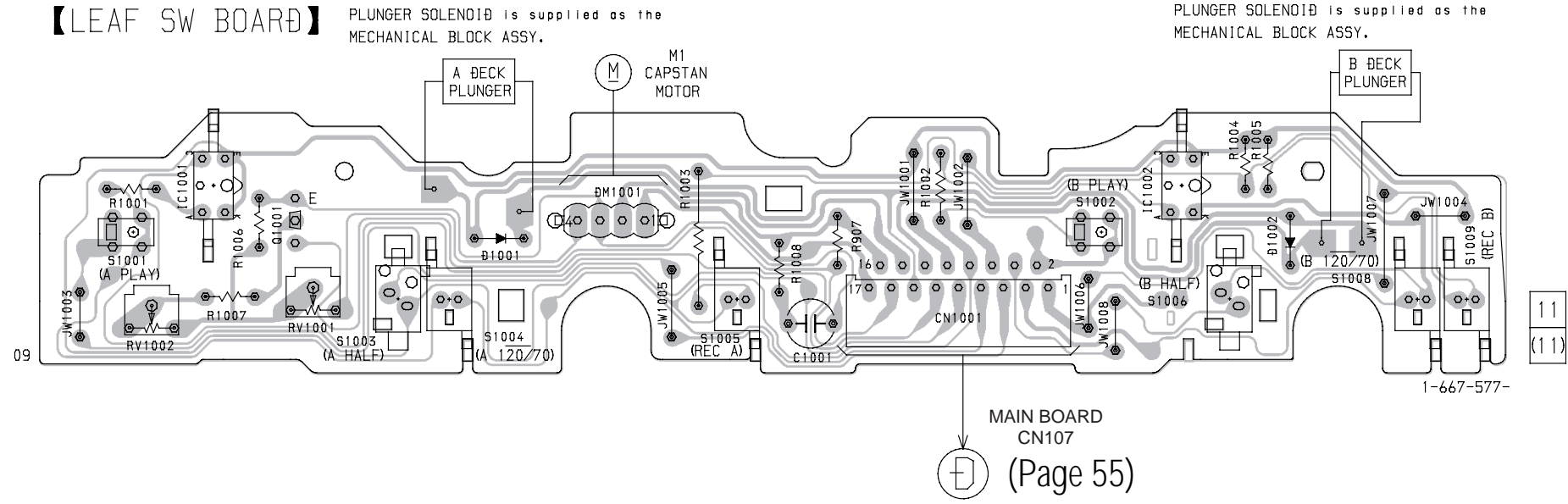

• Semiconductor Location

Ref. No.	Location	Ref. No.	Location
D141	G-9	Q113	H-8
D401	G-10	Q161	E-8
D403	F-11	Q162	D-8
D404	F-11	Q163	H-8
D405	F-10	Q191	D-11
D406	F-11	Q331	C-2
D407	F-11	Q332	D-2
D501	E-5	Q333	C-2
D502	E-5	Q334	D-2
D503	E-5	Q335	C-1
D504	E-5	Q336	E-2
D505	E-6	Q337	E-2
D506	E-6	Q338	F-2
D507	F-3	Q339	F-2
D508	F-2	Q340	E-2
D901	I-6	Q341	E-2
D902	I-5	Q342	E-2
D903	I-6	Q343	E-2
D904	I-6	Q401	E-11
D905	G-6	Q402	E-11
D906	G-7	Q431	G-9
D907	H-4	Q432	H-8
D908	H-4	Q433	H-9
D909	I-5	Q434	H-8
D910	I-4	Q435	H-8
D911	I-4	Q436	G-8
D912	I-4	Q437	G-8
D913	G-3	Q501	E-7
D914	G-5	Q571	E-6
D915	I-3	Q572	E-6
		Q575	F-8
IC101	D-9	Q901	F-6
IC102	F-10	Q902	G-6
IC191	D-11	Q903	H-6
IC301	B-2	Q905	F-6
IC381	A-11	Q906	G-6
IC501	D-4	Q907	G-4
IC502	E-6	Q908	G-5
IC901	G-5	Q909	H-4
IC902	G-3	Q910	I-4
IC903	H-3	Q913	G-6
		Q914	F-7
Q111	F-9	Q951	G-7
Q112	F-9	Q952	G-7

7-18. SCHEMATIC DIAGRAM – LEAF SW Section – • See page 33 for Note on Schematic Diagram.

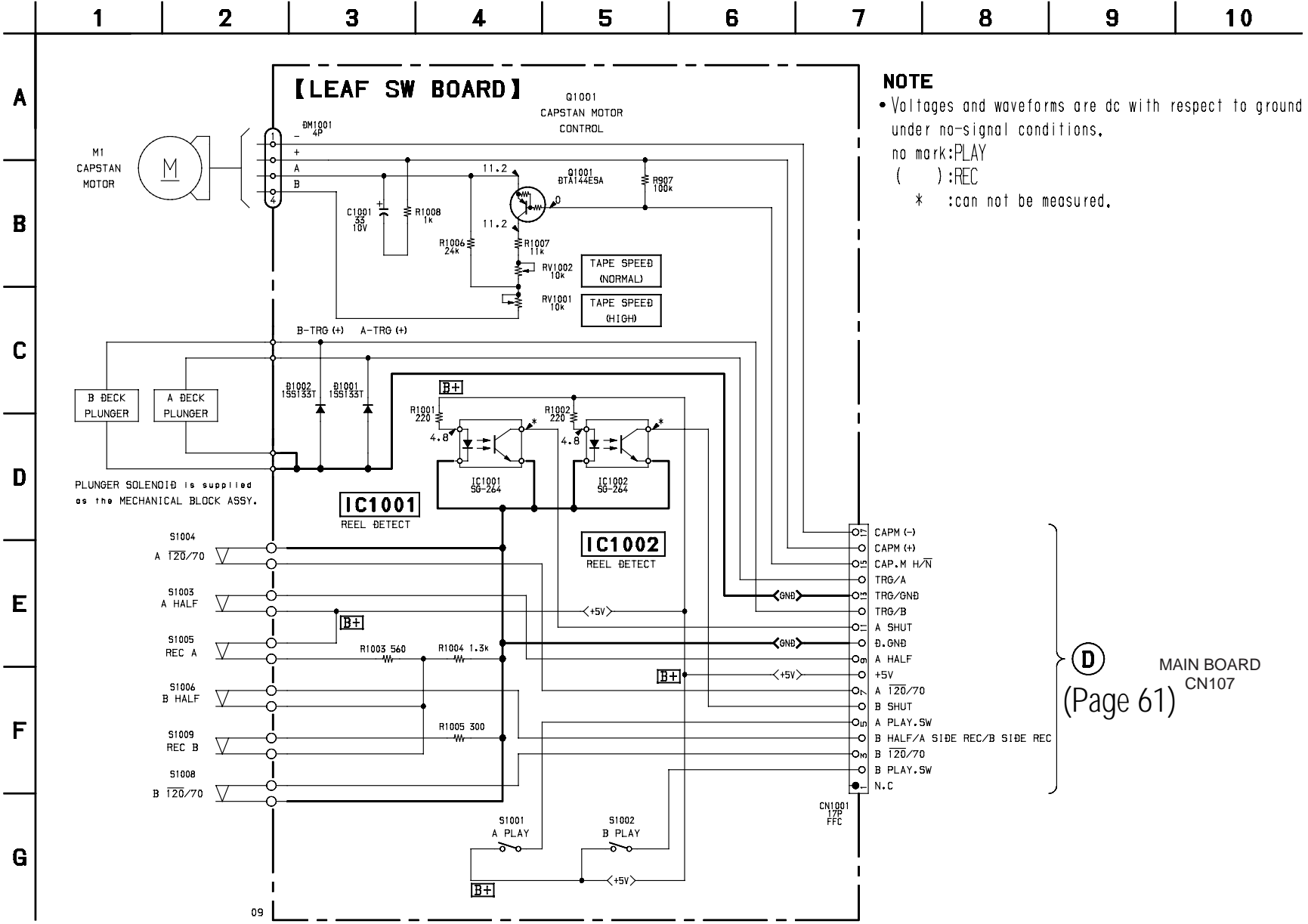

MAIN BOARD CN107 (Page 61)

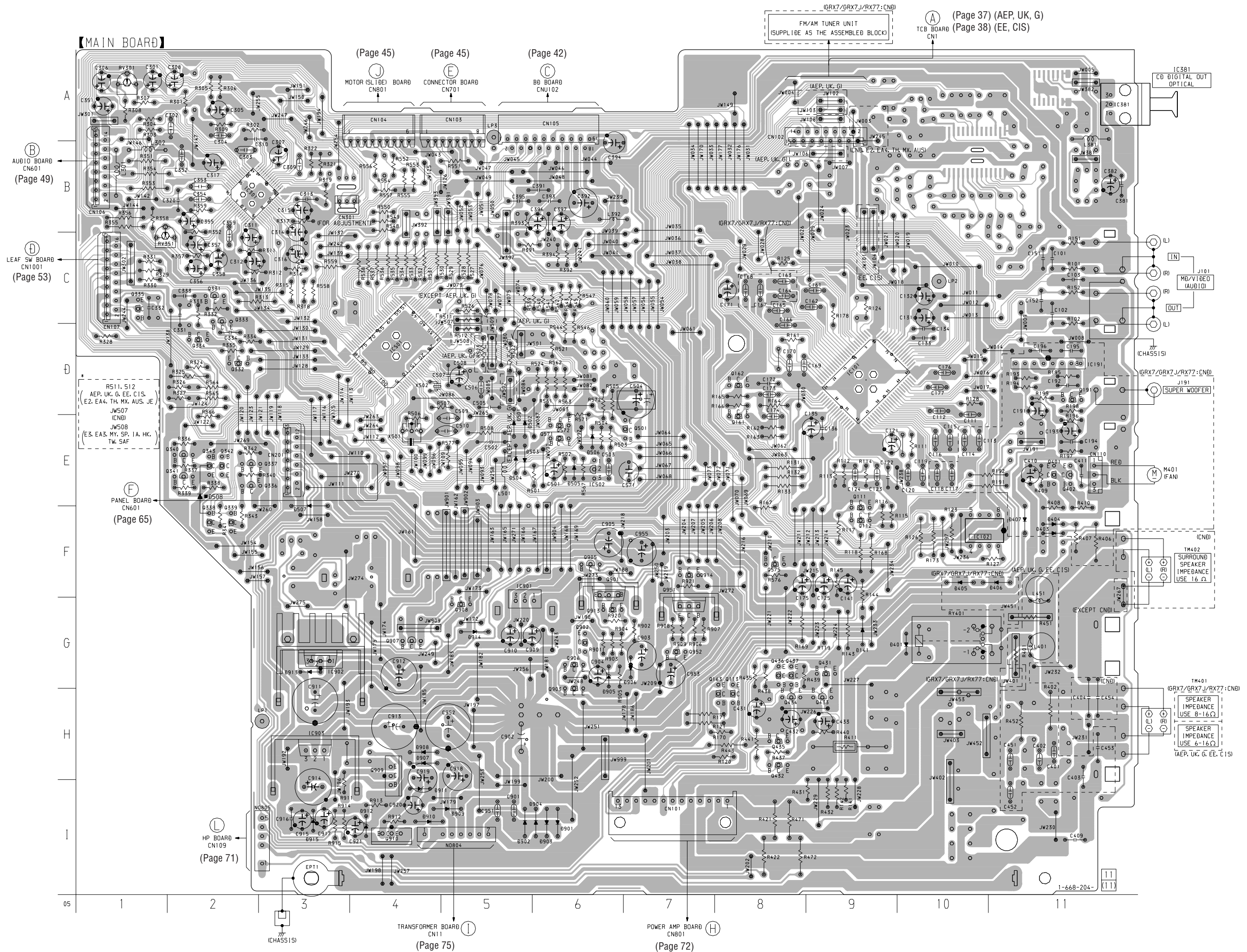

HCD-GRX7/GRX7J/R700/RX77/RX77S

7-20. SCHEMATIC DIAGRAM – MAIN Section (1/4) –
 • See page 33 for Note on Schematic Diagram. • See page 55 and 56 for Printed Wiring Board.

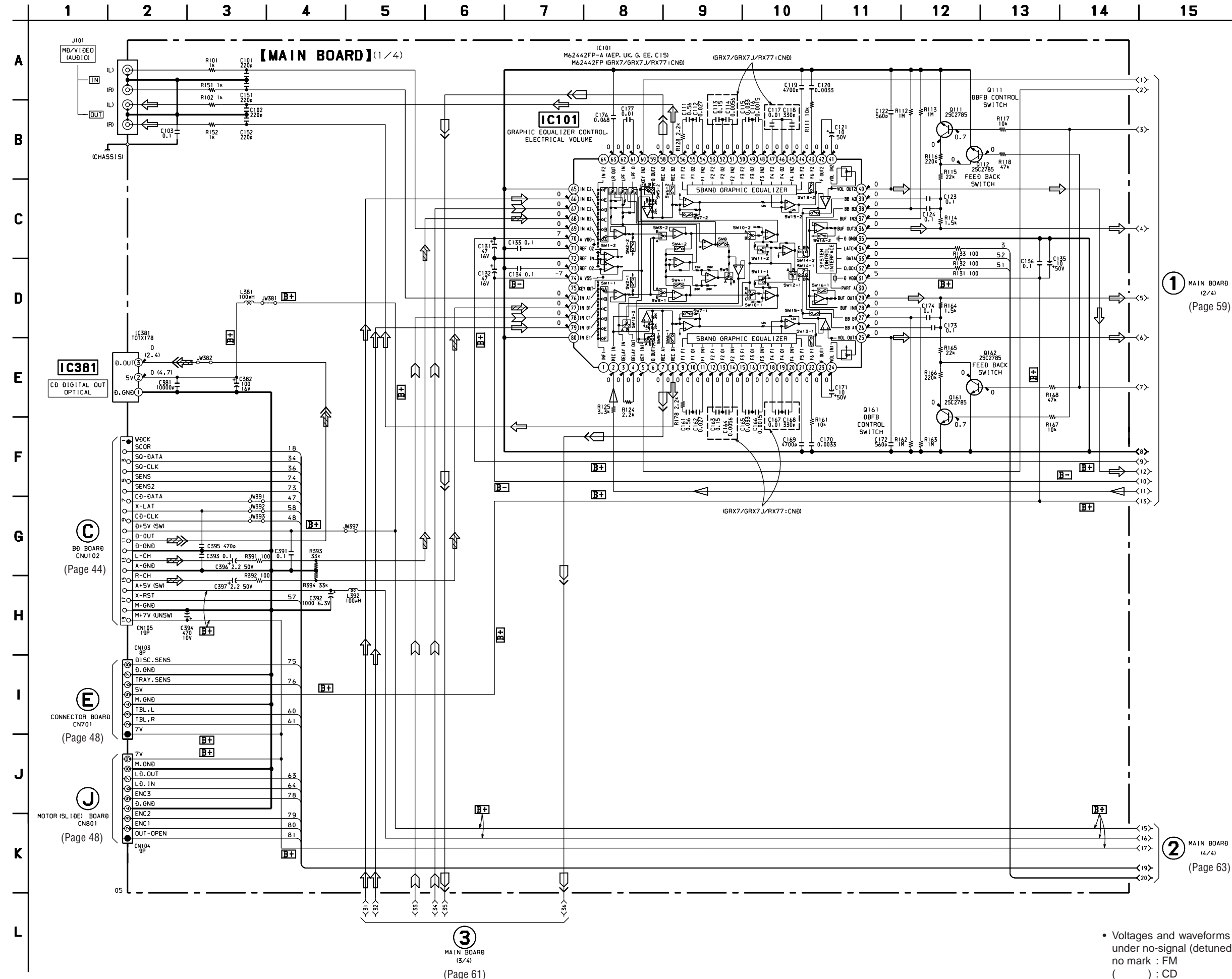

• Voltages and waveforms are dc with respect to ground under no-signal (detuned) conditions.
 no mark : FM
 () : CD

7-21. SCHEMATIC DIAGRAM – MAIN Section (2/4) –

• See page 33 for Note on Schematic Diagram. • See page 55 and 56 for Printed Wiring Board.

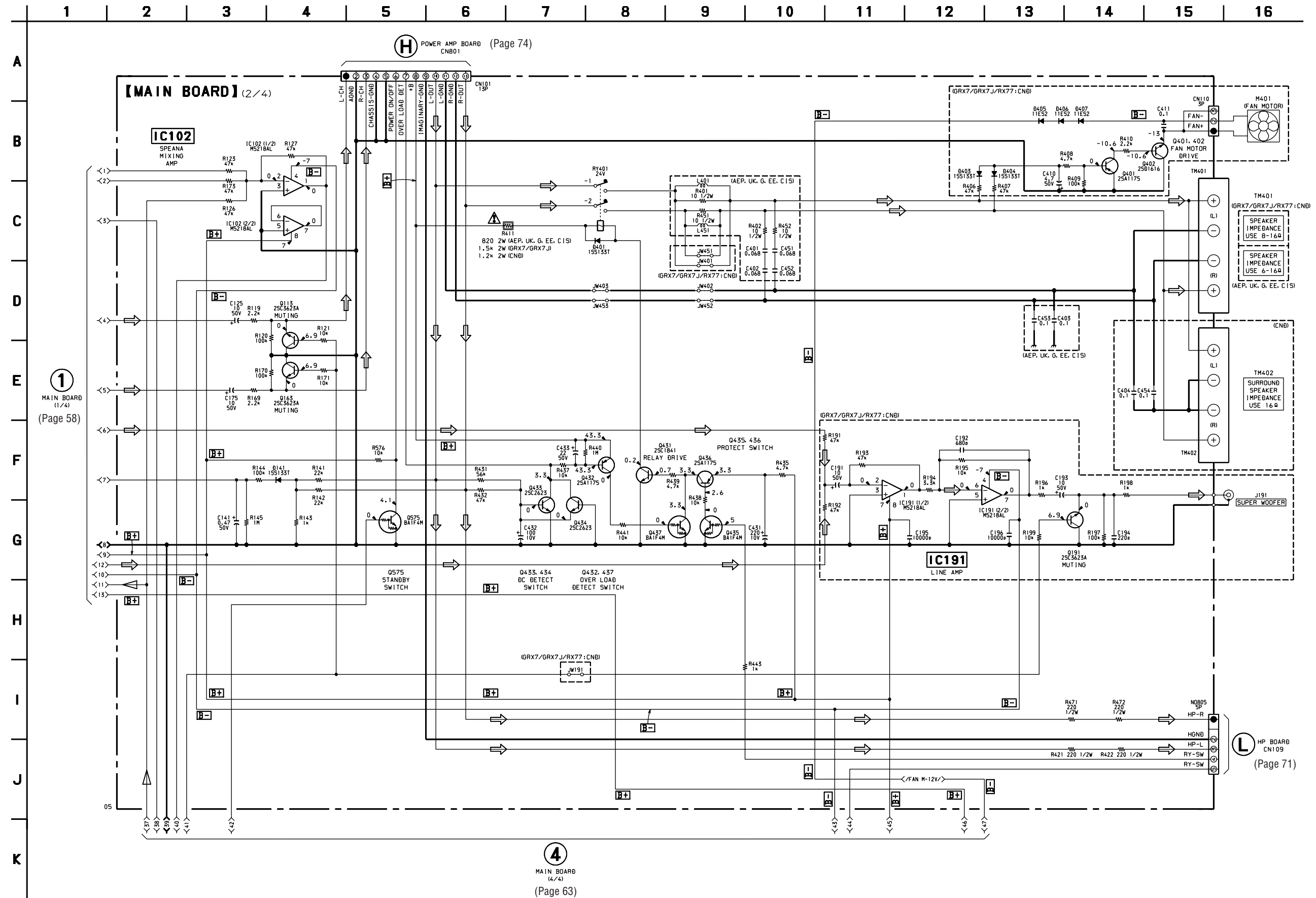

• Voltages and waveforms are dc with respect to ground under no-signal (detuned) conditions.
no mark : FM

The components identified by mark Δ or dotted line with mark Δ are critical for safety. Replace only with part number specified.

Les composants identifiés par une marque Δ sont critiques pour la sécurité. Ne les remplacer que par une pièce portant le numéro spécifié.

HCD-GRX7/GRX7J/R700/RX77/RX77S

7-22. SCHEMATIC DIAGRAM - MAIN Section (3/4) -

• See page 33 for Note on Schematic Diagram. • See page 55 and 56 for Printed Wiring Board.

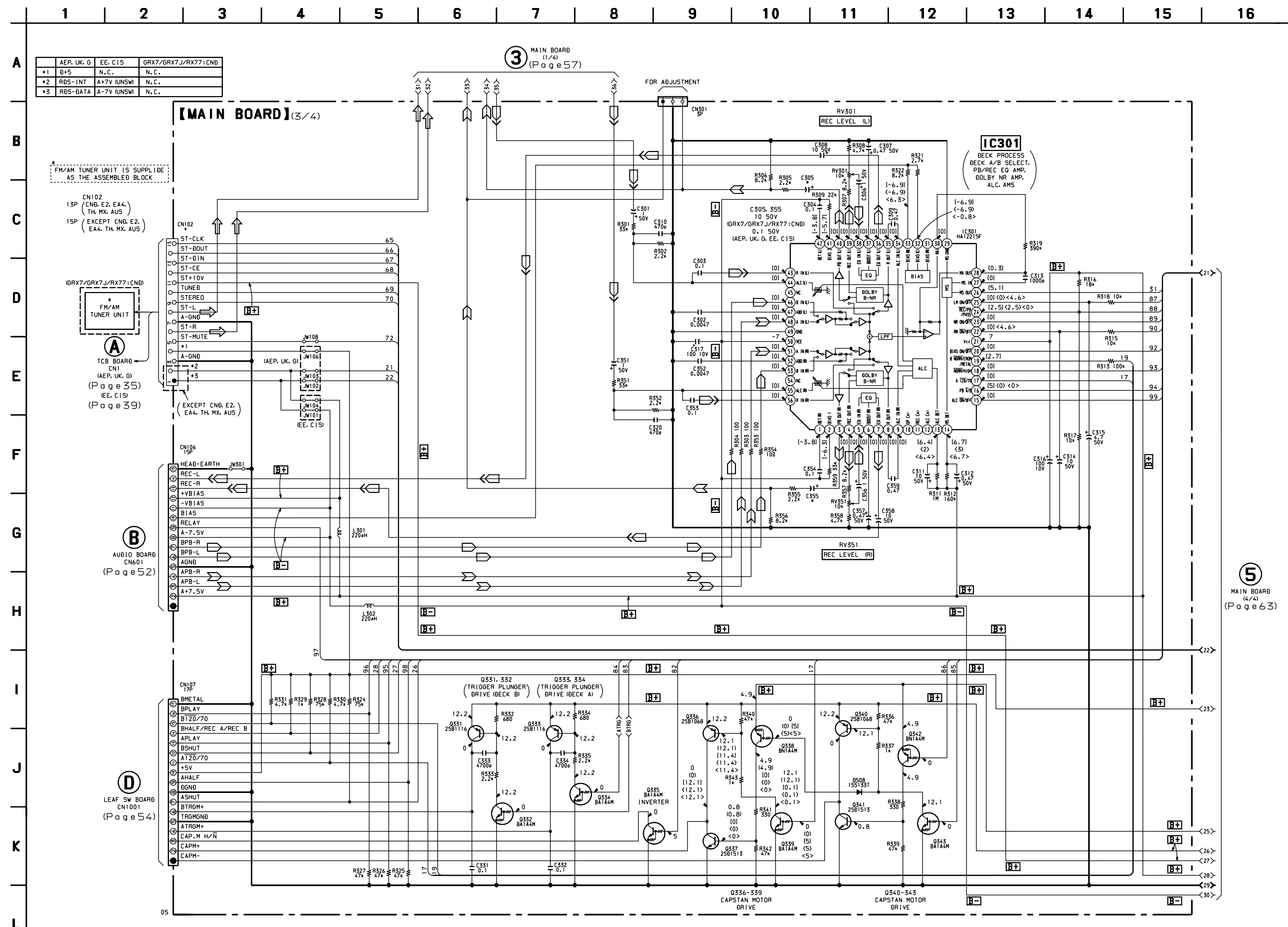

• Voltages and waveforms are dc with respect to ground under no-signal (detuned) conditions.
 no mark : FM { } : PB (DECK A)
 () : CD [] : PB (DECK B)
 < > : REC

7-23. SCHEMATIC DIAGRAM – MAIN Section (4/4) –

• See page 34 for Waveforms. • See page 33 for Note on Schematic Diagram. • See page 55 and 56 for Printed Wiring Board.

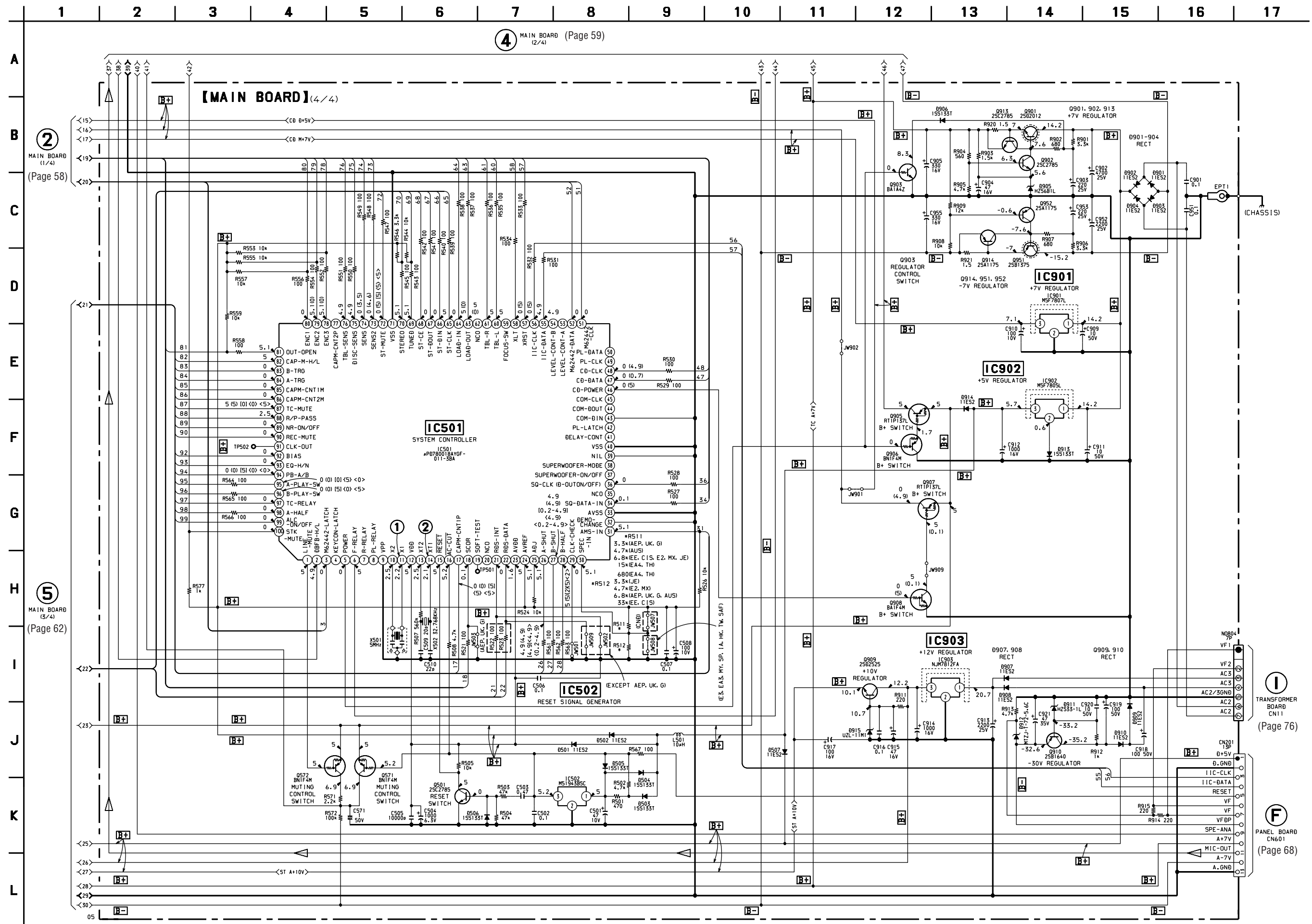

• Voltages and waveforms are dc with respect to ground under no-signal (detuned) conditions.
 no mark : FM { } : PB (DECK A)
 () : CD [] : PB (DECK B)
 < > : REC

7-24. PRINTED WIRING BOARD – PANEL Section –

• See page 20 for Circuit Boards Location. • See page 33 for Note on Printed Wiring Boards.

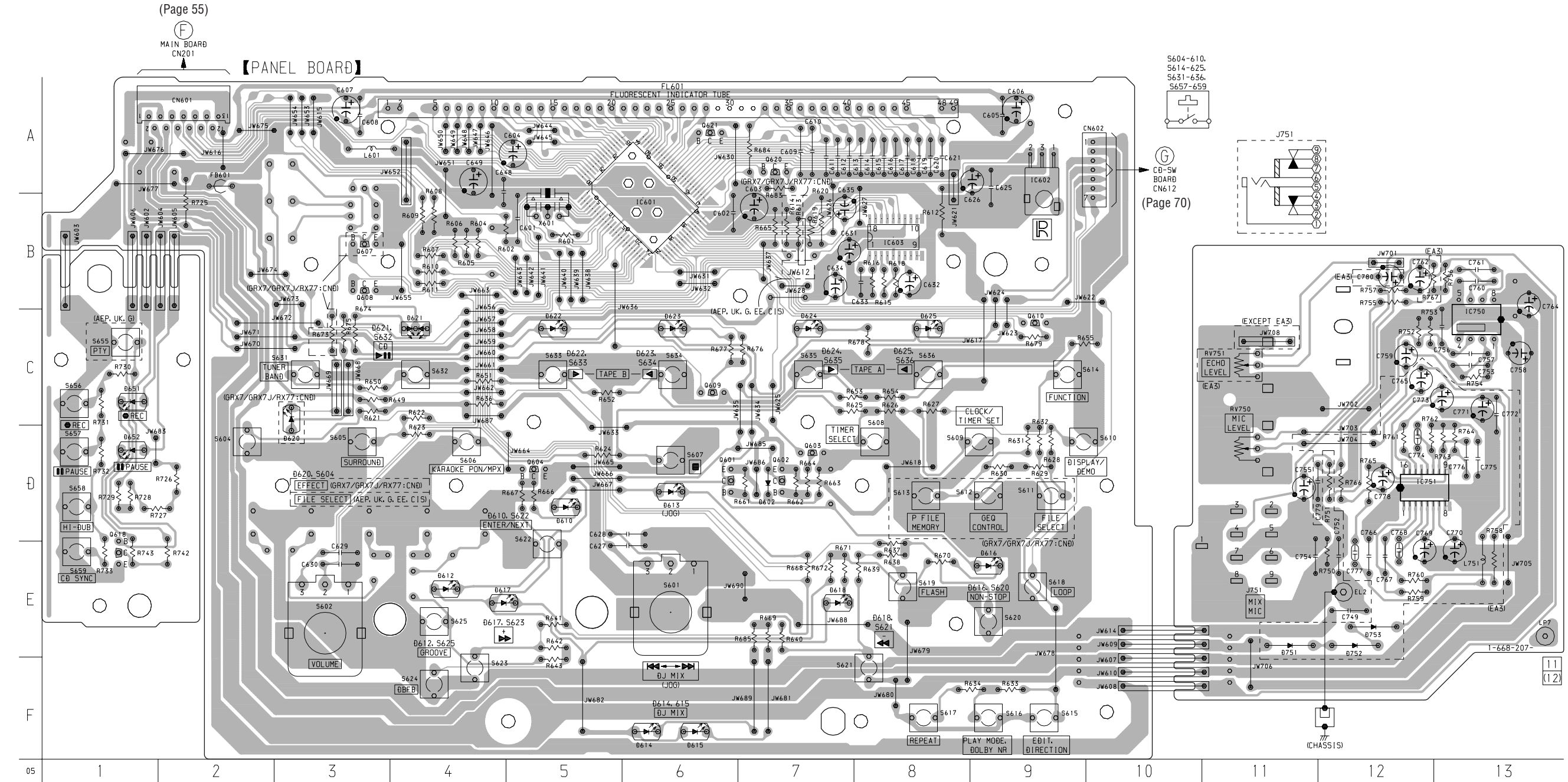

• Semiconductor Location

Ref. No.	Location	Ref. No.	Location	Ref. No.	Location
D602	D-7	D651	C-1	Q604	D-5
D610	D-5	D652	D-1	Q607	B-3
D612	E-4	D751	E-11	Q608	B-3
D613	D-6	D752	E-12	Q609	C-6
D614	F-6	D753	E-12	Q610	C-9
D615	F-6			Q618	E-1
D616	E-9	IC601	B-6	Q620	A-7
D617	E-4	IC602	A-9	Q621	A-6
D618	E-7	IC603	B-8		
D620	C-3	IC750	C-13		
D621	C-4	IC751	D-12		
D622	C-5				
D623	C-6	Q601	D-6		
D624	C-7	Q602	D-7		
D625	C-8	Q603	D-7		

7-25. SCHEMATIC DIAGRAM - PANEL Section -

- See page 34 for Waveform. • See page 81 for IC Block Diagrams.
- See page 33 for Note on Schematic Diagram.

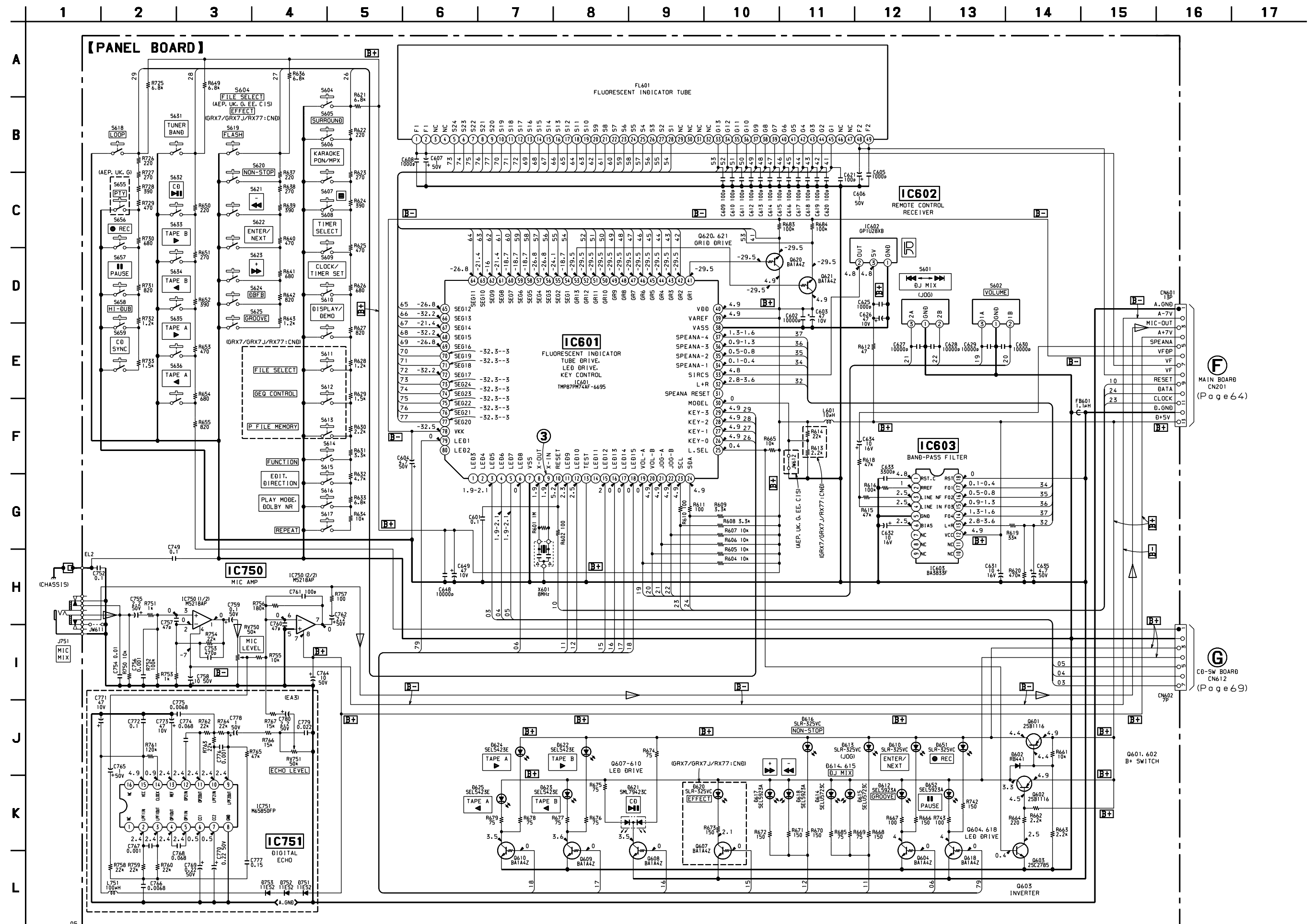

(F) MAIN BOARD CN201 (Page 64)

(G) CD-SW BOARD CN612 (Page 69)

• Voltages and waveforms are dc with respect to ground under no-signal (detuned) conditions. no mark : FM

7-26. PRINTED WIRING BOARD – CD-SW Section –

• See page 20 for Circuit Boards Location. • See page 33 for Note on Printed Wiring Boards.

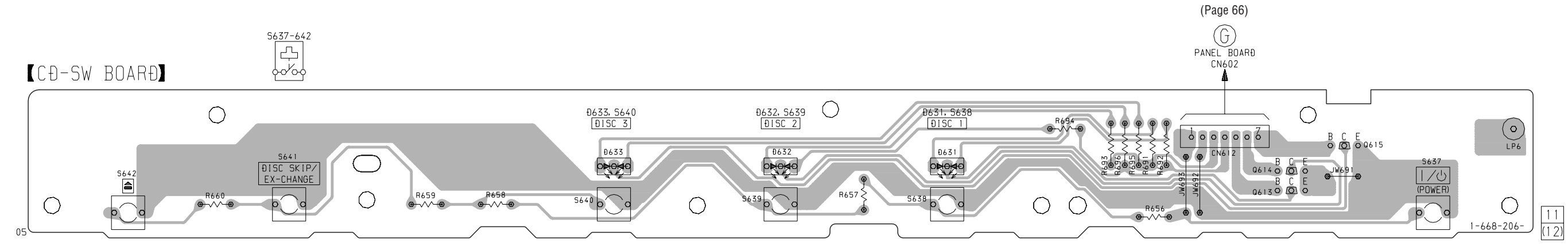

7-27. SCHEMATIC DIAGRAM – CD-SW Section –

• See page 33 for Note on Schematic Diagram.

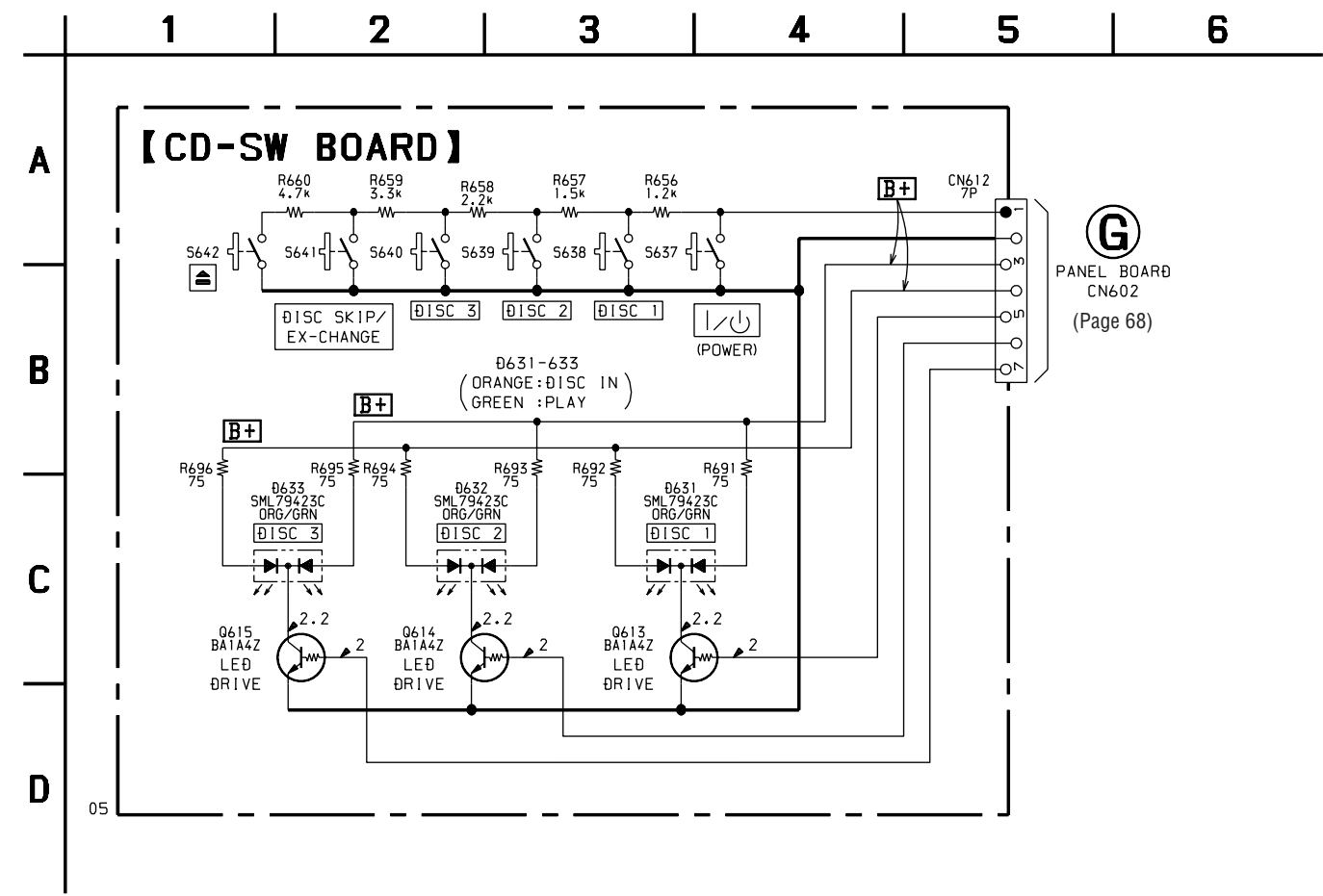

• Voltages and waveforms are dc with respect to ground under no-signal (detuned) conditions.
no mark : FM

7-28. PRINTED WIRING BOARD – HP Section –

• See page 20 for Circuit Boards Location. • See page 33 for Note on Printed Wiring Boards.

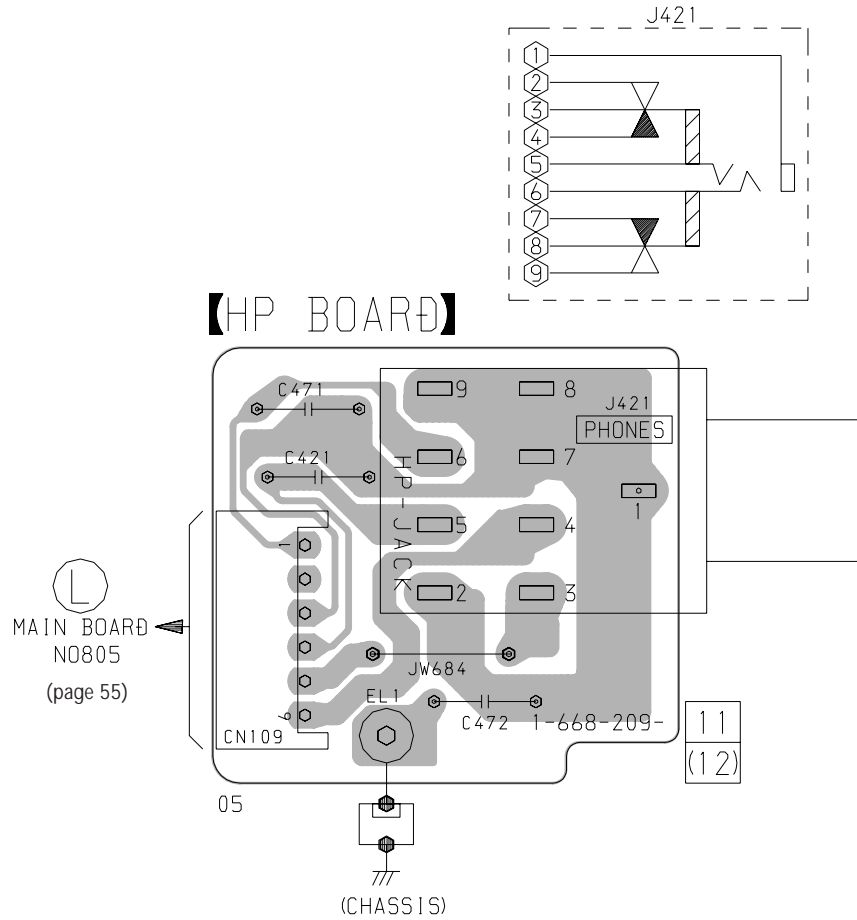

7-29. SCHEMATIC DIAGRAM – HP Section –

• See page 33 for Note on Schematic Diagram.

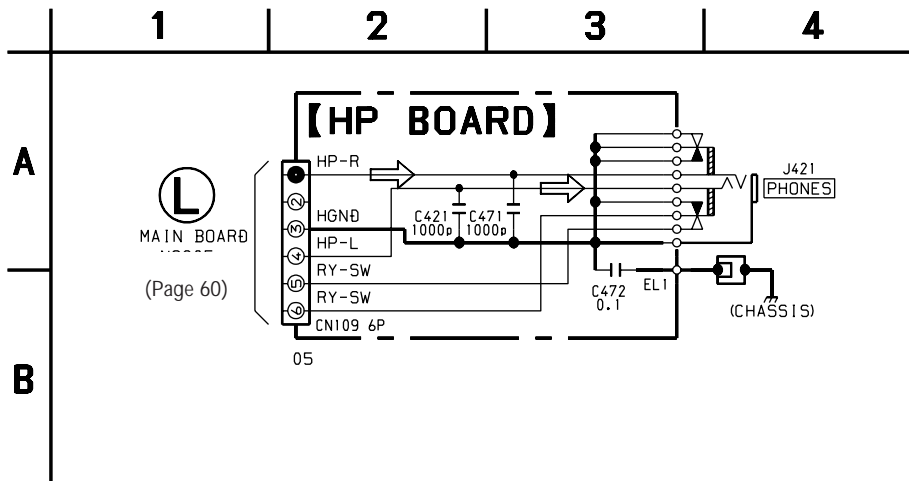

HCD-GRX7/GRX7J/R700/RX77/RX77S

7-30. PRINTED WIRING BOARD – POWER AMP Section –

• See page 20 for Circuit Boards Location. • See page 33 for Note on Printed Wiring Boards.

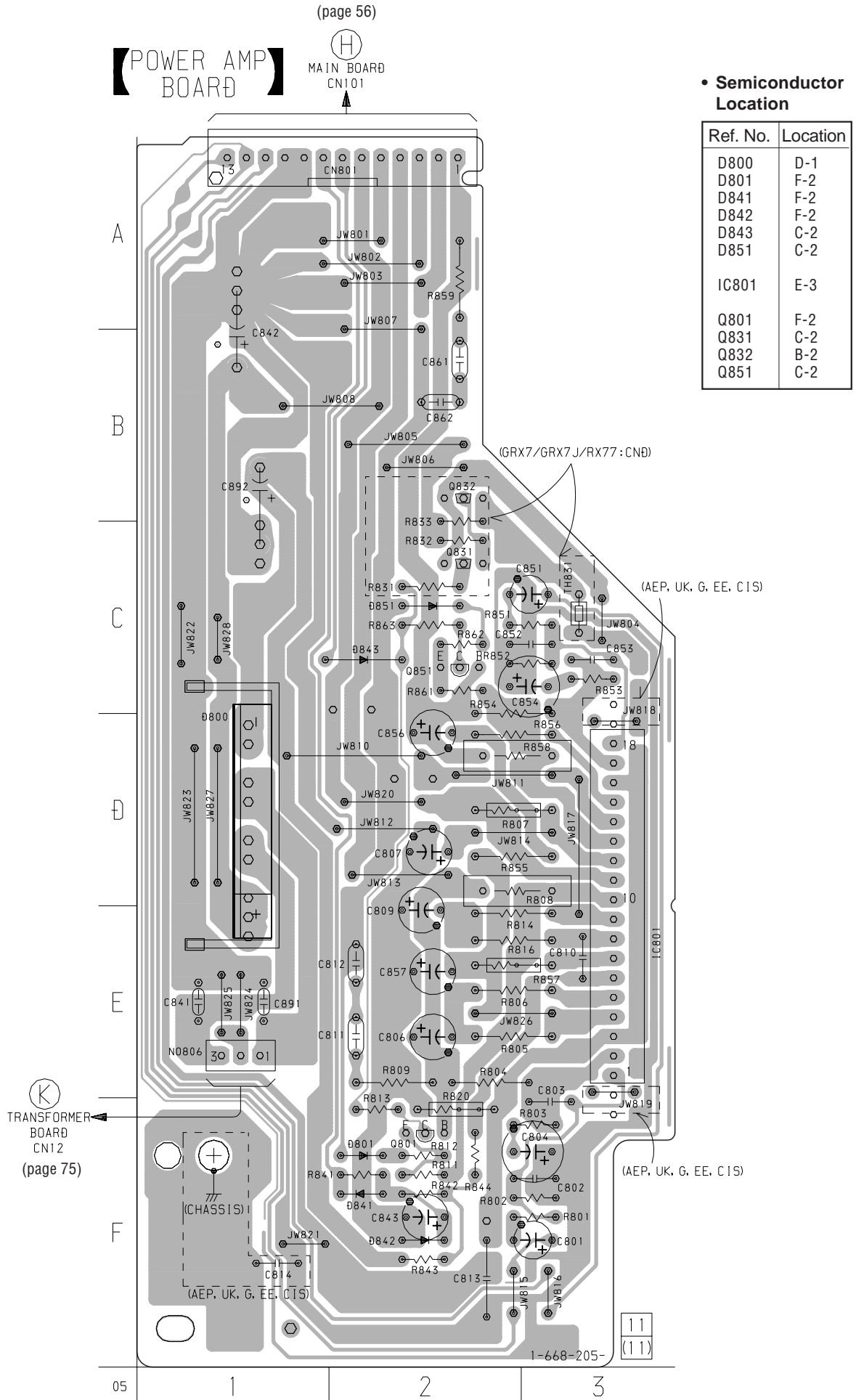

7-31. SCHEMATIC DIAGRAM – POWER AMP Section –
 • See page 33 for Note on Schematic Diagram.

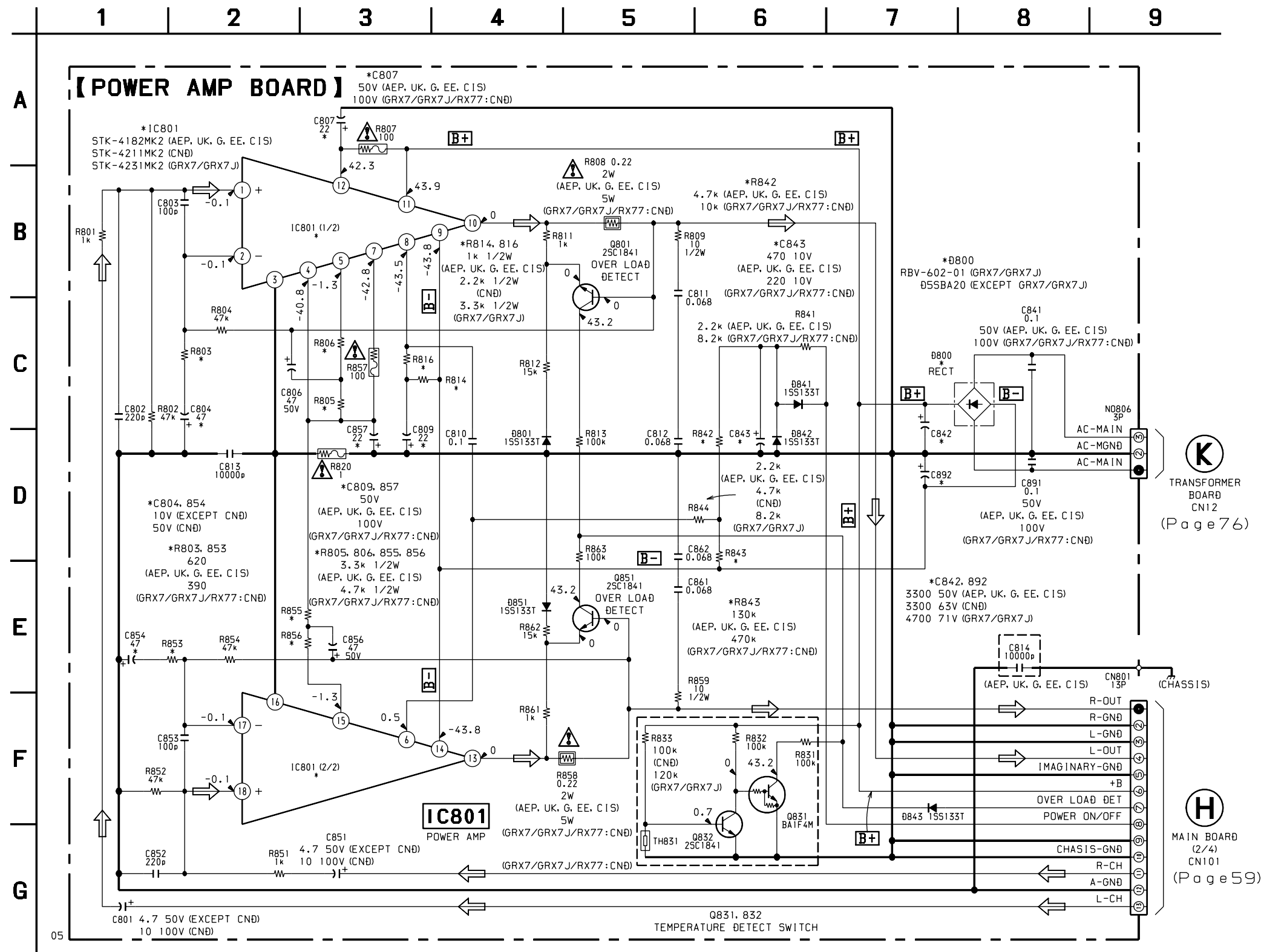

• Voltages and waveforms are dc with respect to ground under no-signal (detuned) conditions.
 no mark : FM

The components identified by mark Δ or dotted line with mark Δ are critical for safety. Replace only with part number specified.

Les composants identifiés par une marque Δ sont critiques pour la sécurité. Ne les remplacer que par une pièce portant le numéro spécifié.

HCD-GRX7/GRX7J/R700/RX77/RX77S

7-32. PRINTED WIRING BOARD – TRANSFORMER Section –

• See page 20 for Circuit Boards Location. • See page 33 for Note on Printed Wiring Board.

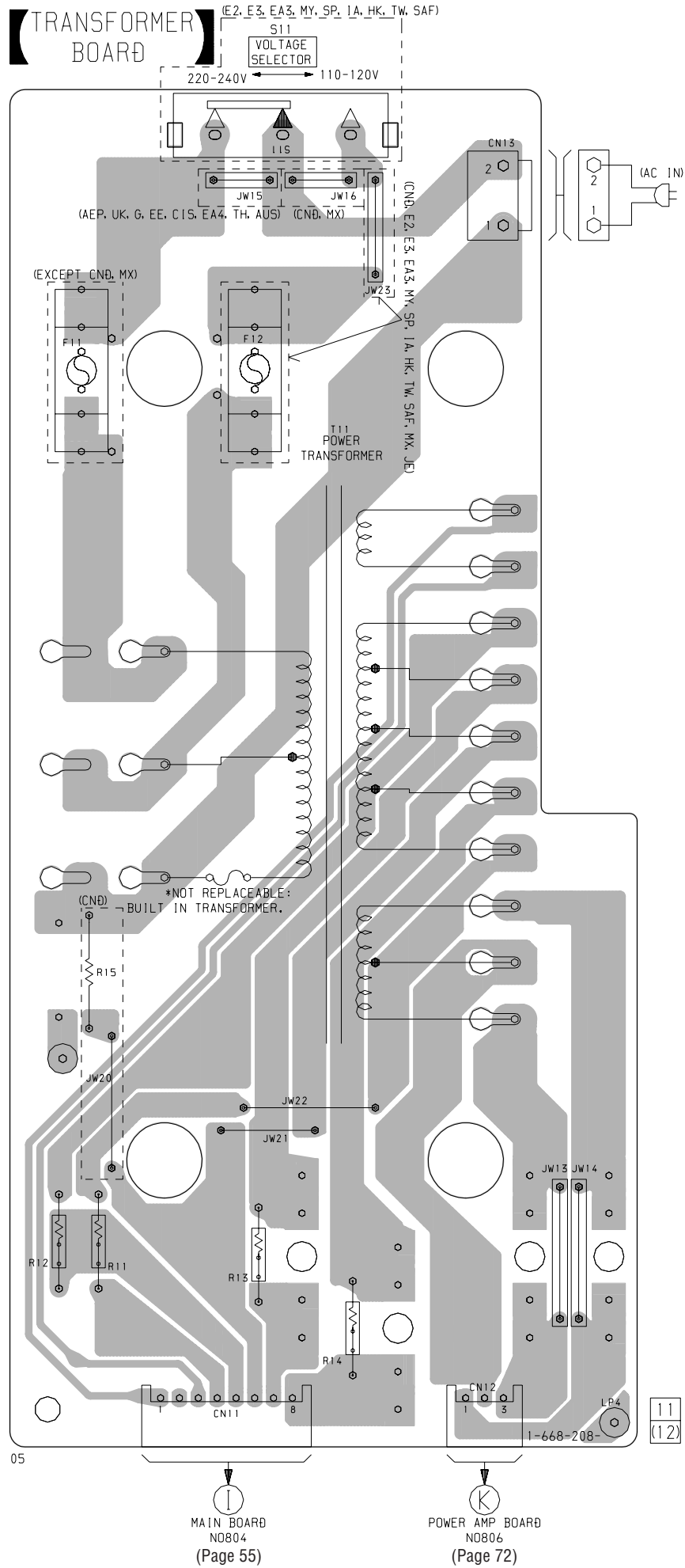

7-33. SCHEMATIC DIAGRAM – TRANSFORMER Section –

• See page 33 for Note on Schematic Diagram.

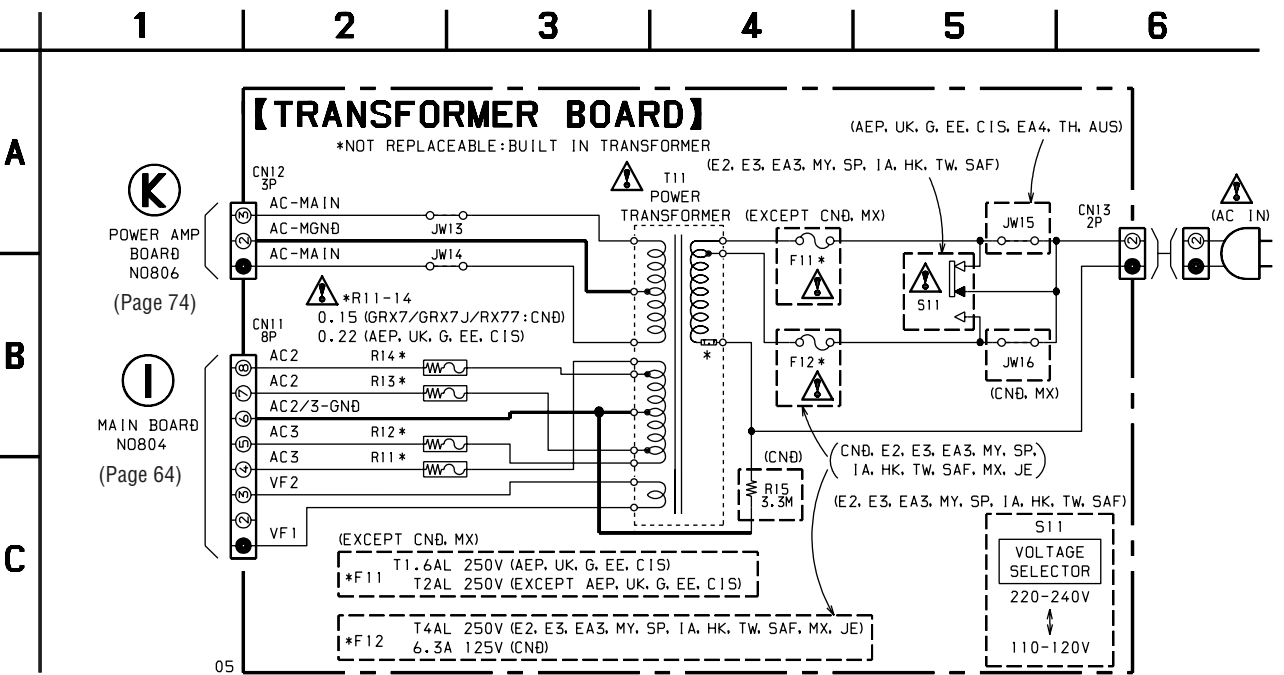

The components identified by mark or dotted line with mark are critical for safety. Replace only with part number specified.

Les composants identifiés par une marque sont critiques pour la sécurité. Ne les remplacer que par une pièce portant le numéro spécifié.

MAIN BOARD NO804 (Page 55)

POWER AMP BOARD NO806 (Page 72)

IC1701 IR3R42 (East European, CIS models)

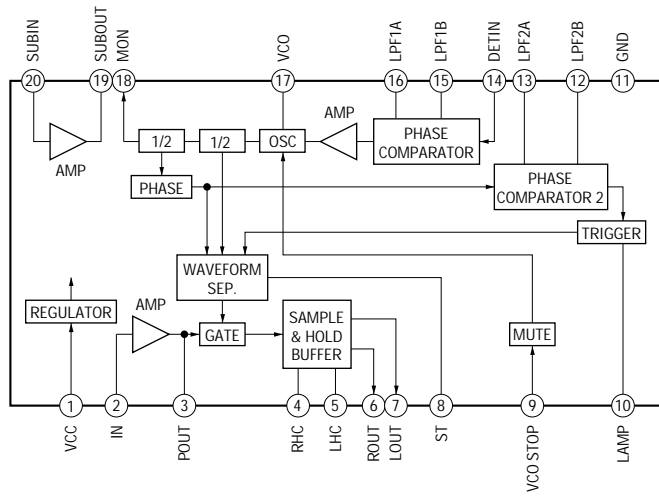

IC1702 μ PD4053BC (East European, CIS models)

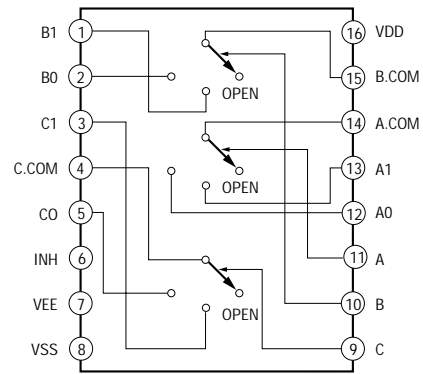

IC1752 BU1922 (AEP, UK, German models)

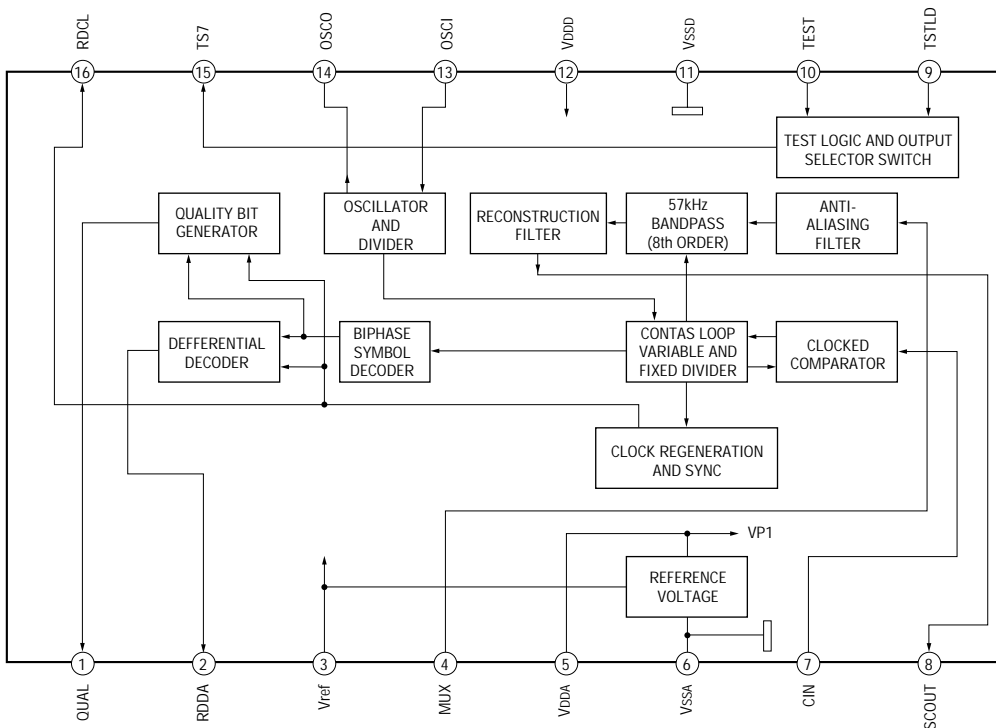

- BD Board -

IC101 CXA1992AR

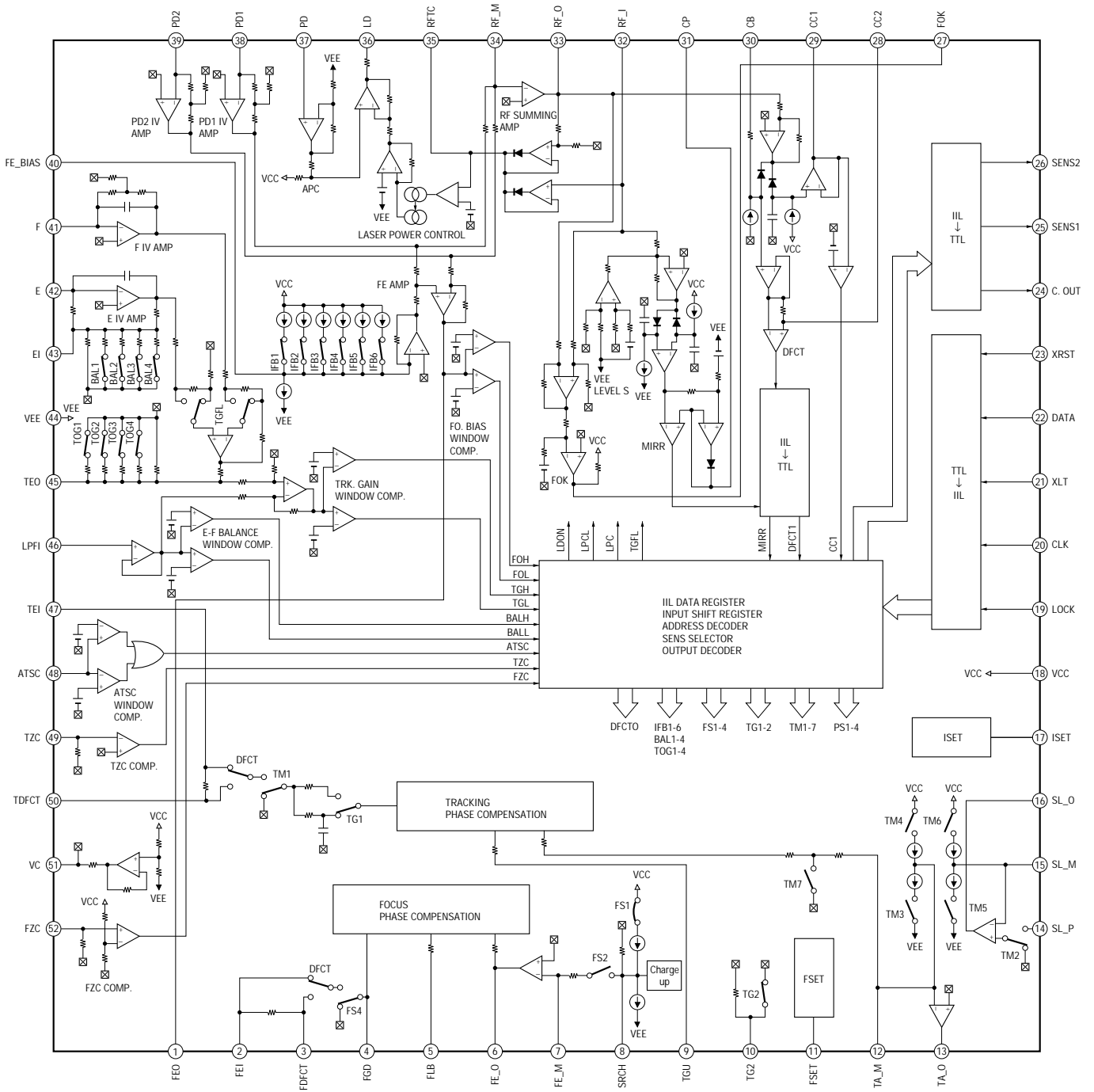

IC102 BA5941FP-E2

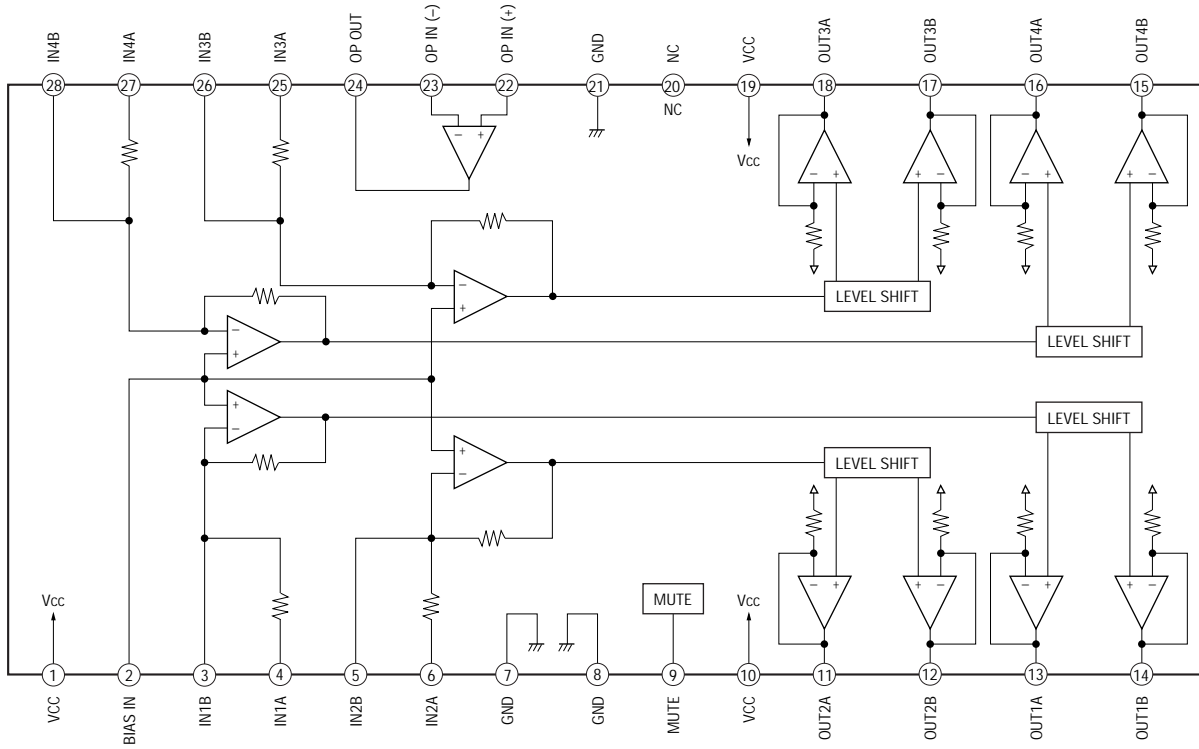

IC103 CXD2519Q

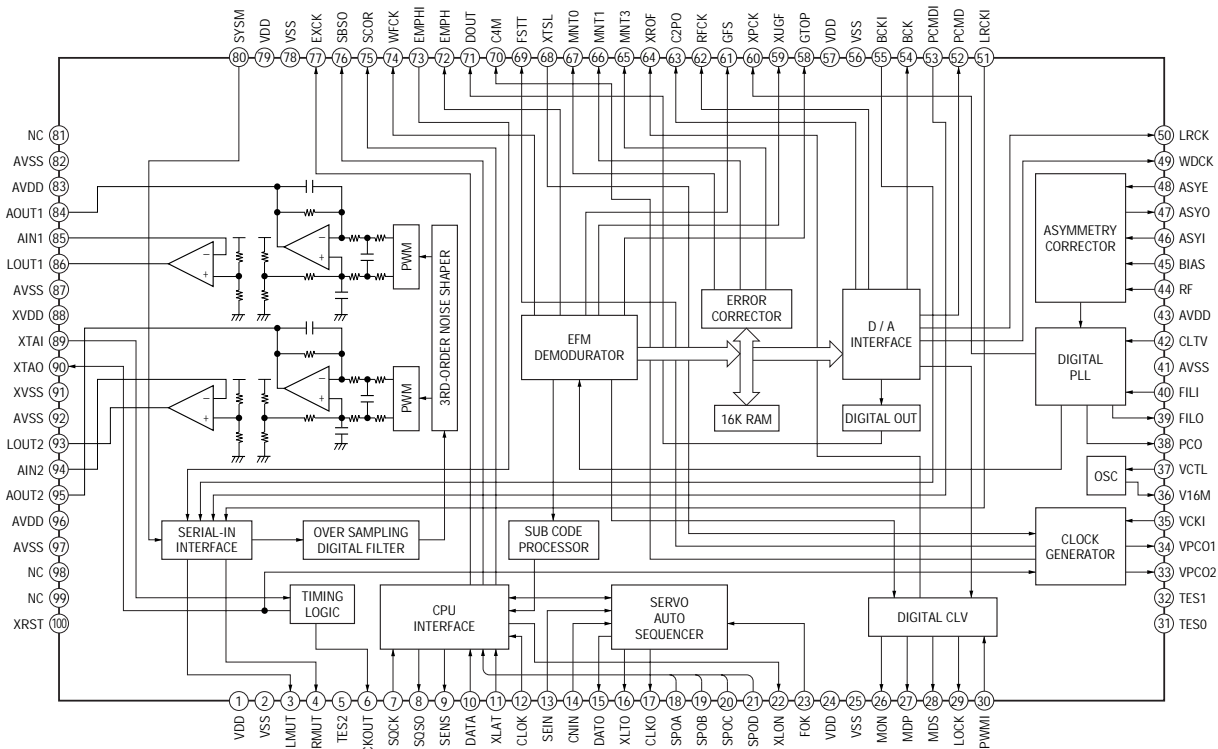

– MOTOR (TURN) Board –

IC701 M54641L

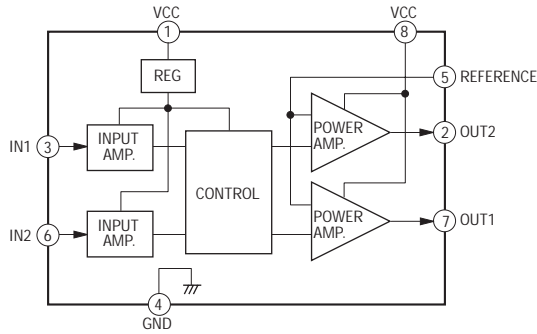

– PANEL Board –

IC603 BA3833F-E2

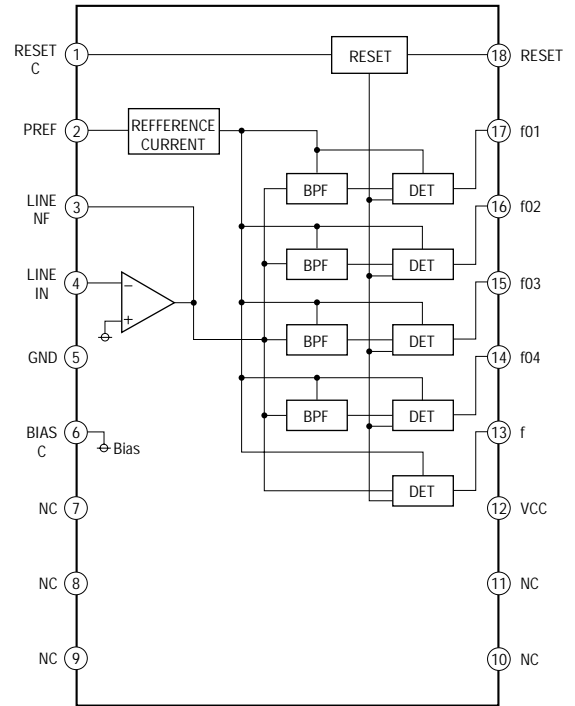

– MOTOR (SLIDE) Board –

IC801 BA6286N

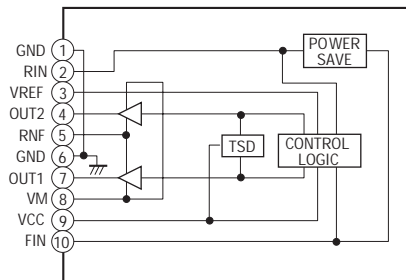

IC751 M65850FP (Saudi Arabia model)

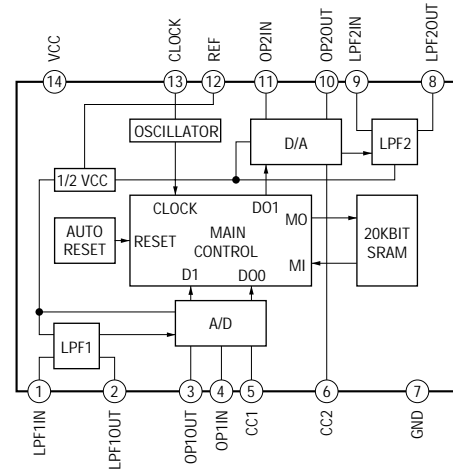

– AUDIO Board –

IC602 μ PC1330HA

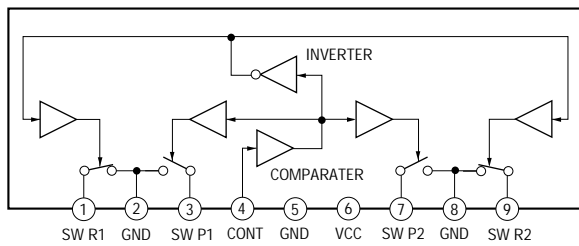

7-34. IC PIN FUNCTION DESCRIPTION

• MAIN BOARD IC501 μ PD780018AYGF-011-3BA (SYSTEM CONTROLLER)

Pin No.	Pin Name	I/O	Function
1	LINE-MUTE	O	Line muting on/off control signal output terminal "L": muting on
2	DBFB-H/L	O	DBFB normal/high selection signal output to the M62442FP (IC101) "L": DBFB high, "H": DBFB low
3	M62442-LATCH	O	Serial data latch pulse output to the M62442FP (IC101)
4	KEYCON-LATCH	O	Serial data latch pulse output terminal Not used (open)
5	POWER	O	Power on/off control signal output for the audio system (+5V) and deck, panel, audio system (+7V) "L": power on, "H": standby
6	F-RELAY	O	Relay drive signal output for the speaker protect "H": on
7	R-RELAY	O	Relay drive signal output for the speaker protect "H": on Not used (open)
8	PL-RELAY	O	Relay drive signal output for the speaker protect "H": on Not used (open)
9	VPP	—	Ground terminal
10	X2	O	Main system clock output terminal (5 MHz)
11	X1	I	Main system clock input terminal (5 MHz)
12	VDD	—	Power supply terminal (+5V)
13	XT2	O	Sub system clock output terminal (32.768 kHz)
14	XT1	I	Sub system clock input terminal (32.768 kHz)
15	$\overline{\text{RESET}}$	I	System reset signal input from the reset signal generator (IC502) "L": reset For several hundreds msec. after the power supply rises, "L" is input, then it changes to "H"
16	$\overline{\text{AC-CUT}}$	I	AC off detection signal input from the reset signal generator (IC502)
17	CAPM-CNT1P	O	Capstan motor (M1) drive signal output terminal
18	SCOR	I	Subcode sync (S0+S1) detection signal input from the CXD2519Q (IC103)
19	SOFT-TEST	O	Output terminal for the software test (open)
20	NCO	O	Not used (open)
21	RDS-INT	I	Serial data reading clock signal input from the RDS decoder (IC1752) Used for the AEP, UK, German models (Except AEP, UK, German models: not used (fixed at "L"))
22	RDS-DATA	I	Serial data input from the RDS decoder (IC1752) Used for the AEP, UK, German models (Except AEP, UK, German models: not used (fixed at "L"))
23	AVDD	—	Power supply terminal (+5V) (for A/D conversion)
24	AVREF	I	Reference voltage (+5V) input terminal (for A/D conversion)
25	ADJ	I	Setting terminal for the CD test mode Normally: fixed at "H"
26	A-SHUT	I	Shut off detection signal input from the deck-A side reel pulse detector (IC1001)
27	B-SHUT	I	Shut off detection signal input from the deck-B side reel pulse detector (IC1002)
28	B-HALF	I	Detection input from the deck-B half detect switch (S1006)
29	CLK-CHECK	I	Not used (fixed at "L")
30	SPEC-IN	I	Setting terminal for the version
31	AMS-IN	I	Automatic music sensor detection signal input from the HA12215F (IC301)
32	DEMO-CHANGE	I	Setting terminal for the demonstration H/L Fixed at "L"
33	AVSS	—	Ground terminal (for A/D conversion)
34	SQ-DATA-IN	I	Sub-code Q data input from the CXD2519Q (IC103)
35	NCO	O	Not used (open)
36	SQ-CLK (D-OUT ON/OFF)	O	Sub-code Q data reading clock signal output to the CXD2519Q (IC103)
37	SUPERWOOFER- ON/OFF	O	Super woofer speaker on/off control signal output terminal Not used (open)
38	SUPERWOOFER MODE	O	Super woofer speaker mode control signal output terminal Not used (open)
39	NIL	I	Not used (fixed at "L")
40	VSS	—	Ground terminal

Pin No.	Pin Name	I/O	Function
41	DELAY-CONT	O	Serial data latch pulse output terminal Not used (open)
42	PL-LATCH	O	Serial data latch pulse output terminal Not used (open)
43	COM-DIN	I	Serial data input terminal Not used (fixed at "L")
44	COM-DOUT	O	Serial data output terminal Not used (open)
45	COM-CLK	O	Serial data transfer clock signal output terminal Not used (open)
46	CD-POWER	O	Power on/off control signal output for the CD mechanism deck section "H": power on, "L": standby
47	CD-DATA	O	Serial data output to the CXD2519Q (IC103)
48	CD-CLK	O	Serial data transfer clock signal output to the CXD2519Q (IC103)
49	PL-CLK	O	Serial data transfer clock signal output terminal Not used (open)
50	PL-DATA	O	Serial data output terminal Not used (open)
51	M62442-CLK	O	Serial data transfer clock signal output to the M62442FP (IC101)
52	M62442-DATA	O	Serial data output to the M62442FP (IC101)
53	LEVEL-CONT-A	O	Level control signal output terminal Not used (open)
54	LEVEL-CONT-B	O	Level control signal output terminal Not used (open)
55	IIC-DATA	I/O	Communication data bus with the fluorescent indicator tube driver (IC601)
56	IIC-CLK	I/O	Communication data reading clock signal input or transfer clock signal output with the fluorescent indicator tube driver (IC601)
57	$\overline{\text{XRST}}$	O	Reset signal output to the CXA1992AR (IC101), BA5941FP (IC102) and CXD2519Q (IC103) on the CD mechanism deck section "L": reset
58	XLT	O	Serial data latch pulse output to the CXD2519Q (IC103)
59	FOCUS-SW	O	Focus control signal output terminal Not used (open)
60	TBL-L	O	Motor drive signal output to the disc tray turn motor driver (IC701) *1
61	TBL-R	O	Motor drive signal output to the disc tray turn motor driver (IC701) *1
62	NCO	O	Not used (open)
63	LOAD-OUT	O	Motor drive signal output to the disc tray slide motor driver (IC801) *2
64	LOAD-IN	O	Motor drive signal output to the disc tray slide motor driver (IC801) *2
65	ST-CLK	O	PLL serial data transfer clock signal output to the FM/AM tuner unit or PLL (IC21)
66	ST-DIN	I	PLL serial data input from the FM/AM tuner unit or PLL (IC21)
67	ST-DOUT	O	PLL serial data output to the FM/AM tuner unit or PLL (IC21)
68	ST-CE	O	PLL chip enable signal output to the FM/AM tuner unit or PLL (IC21)
69	TUNED	I	Tuning detection signal input from the FM/AM tuner unit or LA1838 (IC41) "L": tuned
70	STEREO	I	FM stereo detection signal input from the FM/AM tuner unit or LA1838 (IC41) "L": stereo
71	VSS	—	Ground terminal

*1 Disc tray turn motor (M701) control

Terminal \ Mode	STOP	COUNTER-CLOCKWISE	CLOCKWISE	BRAKE
TBL-L (pin 60)	"H"	"L"	"H"	"L"
TBL-R (pin 61)	"H"	"H"	"L"	"L"

*2 Disc tray slide motor (M801) control

Terminal \ Mode	STOP	TABLE IN	TABLE OUT	BRAKE
LOAD-OUT (pin 63)	"H"	"H"	"L"	"L"
LOAD-IN (pin 64)	"H"	"L"	"H"	"L"

Pin No.	Pin Name	I/O	Function
72	ST-MUTE	O	Tuner muting control signal output to the FM/AM tuner unit or LA1838 (IC41) "L": muting on
73	SENS2	I	Internal status (SENSE) signal input from the CXA1992AR (IC101)
74	SENS	I	Internal status (SENSE) signal input from the CXD2519Q (IC103)
75	DISC-SENS	I	Disc status detection signal input from the disc sensor (IC703)
76	TBL-SENS	I	Disc tray status detection signal input from the disc tray sensor (IC702)
77	CAPM-CNT2P	O	Capstan motor (M1) drive signal output terminal
78	ENC3	I	Detection signal input from the disc tray address detect rotary encoder (S811)
79	ENC2	I	
80	ENC1	I	
81	OUT-OPEN	I	Detection signal input from the disc tray open/close detect switch (S801) "L": open, "H": close
82	CAP-M-H/L	O	High/normal speed selection signal output of the capstan motor (M1) "L": high speed, "H": normal speed
83	B-TRG	O	Deck-B side trigger plunger (SL2) drive signal output terminal
84	A-TRG	O	Deck-A side trigger plunger (SL1) drive signal output terminal
85	CAPM-CNT1M	O	Capstan motor (M1) drive signal output terminal
86	CAPM-CNT2M	O	Capstan motor (M1) drive signal output terminal
87	TC-MUTE	O	Line muting on/off selection signal output to the HA12215F (IC301) "L": muting off, "H": muting on
88	R/P-PASS	O	Recording/playback/pass selection signal output to the HA12215F (IC301) "L": recording mode
89	NR-ON/OFF	O	Dolby NR on/off selection signal output to the HA12215F (IC301) "L": dolby off, "H": dolby on
90	REC-MUTE	O	Recording muting on/off selection signal output to the HA12215F (IC301) "L": muting on, "H": muting off
91	CLK-OUT	O	Clock output for the check Not used (open)
92	BIAS	O	Recording bias on/off selection signal output to the HA12215F (IC301) "L": bias off, "H": bias on
93	EQ-H/N	O	Normal/high speed selection signal output to the HA12215F (IC301) "L": normal speed, "H": high speed
94	PB-A/B	O	Deck-A/B selection signal output to the HA12215F (IC301) "L": deck-A, "H": deck-B
95	A-PLAY-SW	I	Detection input from the deck- A play detect switch (S1001) "H": deck-A play
96	B-PLAY-SW	I	Detection input from the deck- B play detect switch (S1002) "H": deck-B play
97	TC-RELAY	O	Recording/playback select signal output to the REC/PB switch (IC602) "L": playback, "H": recording
98	A-HALF	I	Detection input from the deck-A cassette detect switch (S1003) "L": cassette in, "H": no cassette
99	ALC-ON/OFF	O	Automatic limiter control signal output to the HA12215F (IC301) "L": limiter on
100	STK-MUTE	O	Power amplifier on/off selection signal output terminal "L": on, "H": standby

• PANEL BOARD IC601 TMP87PM74F-6695

(FLUORESCENT INDICATOR TUBE DRIVE, LED DRIVE, KEY CONTROL)

Pin No.	Pin Name	I/O	Function
1	LED3	O	LED drive signal output terminal Not used (open)
2	LED4	O	LED drive signal output terminal Not used (open)
3	LED5	O	LED drive signal output terminal (DISC 3)
4	LED6	O	LED drive signal output terminal (DISC 2)
5	LED7	O	LED drive signal output terminal (DISC 1)
6	LED8	O	LED drive signal output terminal (ENTER/NEXT, GROOVE)
7	VSS	—	Ground terminal
8	X-OUT	O	System clock output terminal (8 MHz)
9	X-IN	I	System clock input terminal (8 MHz)
10	$\overline{\text{RESET}}$	I	System reset signal input from the reset signal generator (IC502) “L”: reset For several hundreds msec. after the power supply rises, “L” is input, then it changes to “H”
11	LED9	O	LED drive signal output terminal (JOG, DJ MIX)
12	LED10	O	LED drive signal output terminal (NON-STOP, + ►►, - ◄◄)
13	TEST	I	Connected to ground
14	LED11	O	LED drive signal output terminal Not used (open)
15	LED12	O	LED drive signal output terminal (EFFECT) Used for the GRX7/GRX7J/RX77: Canadian (Except GRX7/GRX7J/RX77: Canadian; Not used (open))
16	LED13	O	LED drive signal output terminal (CD ►►)
17	LED14	O	LED drive signal output terminal (TAPE B ►►/◄◄)
18	LED15	O	LED drive signal output terminal (TAPE A ►►/◄◄)
19	VOL-A	I	Rotary encoder pulse input from the S602 (VOLUME)
20	VOL-B	I	Rotary encoder pulse input from the S602 (VOLUME)
21	JOG-A	I	Jog dial pulse input from the S601 (◄◄ ↔ ►► DJ MIX)
22	JOG-B	I	Jog dial pulse input from the S601 (◄◄ ↔ ►► DJ MIX)
23	SCL	I/O	Communication data reading clock signal input or transfer clock signal output with the system controller (IC501)
24	SDA	I/O	Communication data bus with the system controller (IC501)
25	L.SEL	O	LED selection signal output terminal
26	KEY-0	I	Key input terminal (A/D input) (S604 to 617) (S611 to 613 FILE SELECT, GEQ CONTROL, P FILE MEMORY; GRX7/GRX7J/RX77: Canadian model only) FILE SELECT (AEP, UK, German, East European, CIS models), EFFECT (GRX7/GRX7J/RX77: Canadian), SURROUND, KARAOKE PON/MPX, ■, TIMER SELECT, CLOCK/TIMER SET, DISPLAY/DEMO, FILE SELECT, GEQ CONTROL, P FILE MEMORY, FUNCTION, EDIT/DIRECTION, PLAY MODE/DOLBY NR, REPEAT keys input
27	KEY-1	I	Key input terminal (A/D input) (S619 to 625) FLASH, NON-STOP, - ◄◄, ENTER/NEXT, + ►►, DBFB, GROOVE keys input
28	KEY-2	I	Key input terminal (A/D input) (S631 to 642) TUNER/BAND, CD ►► , TAPE B ►►/◄◄, TAPE A ►►/◄◄, I/⏻ (POWER), DISC 1/2/3, DISC SKIP/EX-CHANGE, ▲ keys input
29	KEY-3	I	Key input terminal (A/D input) (S618, 655 to 659) (S655 PTY: AEP, UK, German models only) LOOP, PTY, ● REC, PAUSE, HI-DUB, CD SYNC, keys input
30	MODEL	I	Destination setting terminal
31	SPEANA RESET	O	Reset signal output terminal “H”: reset Not used (open)
32	L+R	I	Spectrum analyzer drive signal input from the spectrum analyzer band-pass filter (IC603) (for VACS, non-stop signal)
33	SIRCS	I	Remote control signal input from the remote control receiver (IC602)

Pin No.	Pin Name	I/O	Function
34	SPEANA-1	I	Spectrum analyzer drive signal input from the spectrum analyzer band-pass filter (IC603) (for low frequency)
35	SPEANA-2	I	Spectrum analyzer drive signal input from the spectrum analyzer band-pass filter (IC603) (for low and middle frequency)
36	SPEANA-3	I	Spectrum analyzer drive signal input from the spectrum analyzer band-pass filter (IC603) (for middle and high frequency)
37	SPEANA-4	I	Spectrum analyzer drive signal input from the spectrum analyzer band-pass filter (IC603) (for high frequency)
38	VASS	—	Ground terminal
39	VAREF	I	Reference voltage (+5V) input terminal (for A/D conversion)
40	VDD	—	Power supply terminal (+5V)
41 to 53	GR1 to GR13	O	Grid drive signal output to the fluorescent indicator tube (FL601)
54 to 69	SEG1 to SEG16	O	Segment drive signal output to the fluorescent indicator tube (FL601)
70 to 72	SEG19 to SEG17	O	Segment drive signal output to the fluorescent indicator tube (FL601)
73 to 77	SEG24 to SEG20	O	Segment drive signal output to the fluorescent indicator tube (FL601)
78	VKK	—	Power supply terminal (−30V) (for fluorescent indicator tube drive)
79	LED1	O	LED drive signal output terminal (● REC, ■ PAUSE)
80	LED2	O	LED drive signal output terminal Not used (open)

SECTION 8 EXPLODED VIEWS

NOTE:

- XX and -X mean standardized parts, so they may have some difference from the original one.

- Color Indication of Appearance Parts

Example:

KNOB, BALANCE (WHITE) . . . (RED)

↑
↑
 Parts Color Cabinet's Color

- Abbreviation

AUS : Australian	IA : Indonesian
CND : Canadian	JE : Tourist
E2 : 120 V AC Area in E model	MX : Mexican
E3 : 240 V AC Area in E model	MY : Malaysia
EA3 : Saudi Arabia	SAF : South African
EA4 : Israel	SP : Singapore
EE : East European	TH : Thai
G : German	TW : Taiwan
HK : Hong Kong	

- Items marked "*" are not stocked since they are seldom required for routine service. Some delay should be anticipated when ordering these items.

- The mechanical parts with no reference number in the exploded views are not supplied.

- Hardware (# mark) list and accessories and packing materials are given in the last of the electrical parts list.

The components identified by mark Δ or dotted line with mark Δ are critical for safety. Replace only with part number specified.

Les composants identifiés par une marque Δ sont critiques pour la sécurité. Ne les remplacer que par une pièce portant le numéro spécifié.

(1) CASE SECTION

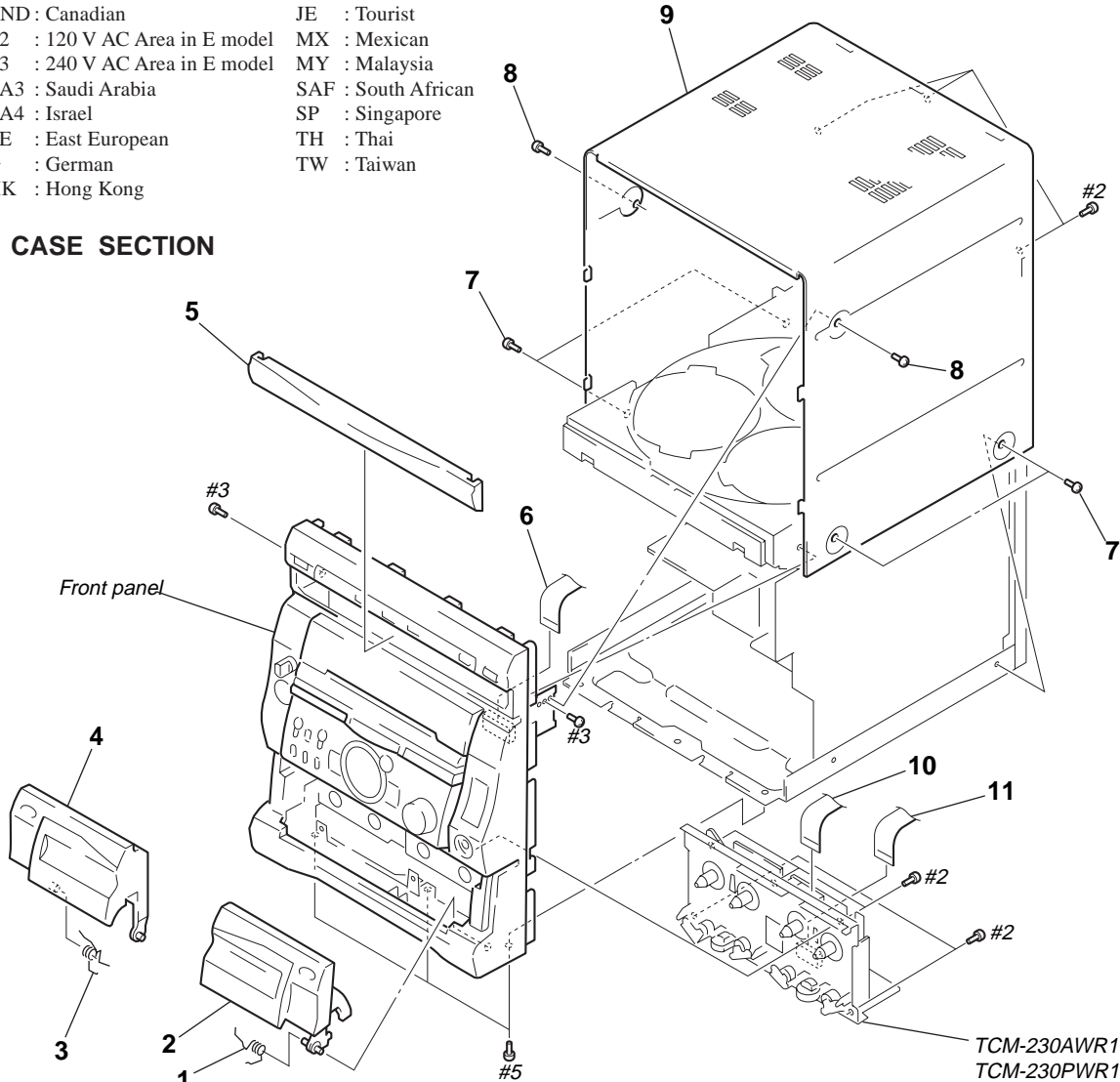

Ref. No.	Part No.	Description	Remark	Ref. No.	Part No.	Description	Remark
1	4-996-733-01	SPRING (B DECK)		5	4-998-222-11	PANEL, LOADING (SILVER) (RX77S)	
2	X-4949-350-1	LID (R) ASSY, CASSETTE (SILVER) (GRX7/GRX7J/RX77: CND)		5	4-998-222-21	PANEL, LOADING (BLACK) (R700)	
2	X-4949-411-1	LID (R) ASSY, CASSETTE (BLACK) (R700)		6	1-769-984-11	WIRE (FLAT TYPE) (13 CORE) (23CM)	
2	X-4949-414-1	LID (R) ASSY, CASSETTE (SILVER) (RX77: AEP, G/RX77S)		7	3-363-099-01	SCREW (CASE 3 TP2) (3X8) (BLACK) (R700)	
3	4-996-732-01	SPRING (A DECK)		7	3-363-099-11	SCREW (CASE 3 TP2) (3X8) (SILVER) (GRX7/GRX7J/RX77/RX77S)	
4	X-4949-349-1	LID (L) ASSY, CASSETTE (SILVER) (GRX7/GRX7J/RX77: CND)		8	3-363-099-41	SCREW (CASE 3 TP2) (3X12) (BLACK) (R700)	
4	X-4949-398-1	LID (L) ASSY, CASSETTE (SILVER) (RX77: AEP, G/RX77S)		8	3-363-099-71	SCREW (CASE 3 TP2) (3X12) (SILVER) (GRX7/GRX7J/RX77/RX77S)	
4	X-4949-410-1	LID (L) ASSY, CASSETTE (BLACK) (R700)		* 9	4-996-728-01	CASE (SILVER) (EXCEPT IA, R700)	
5	4-996-703-21	PANEL, LOADING (SILVER) (CND)		* 9	4-996-728-21	CASE (SILVER) (IA)	
5	4-996-703-31	PANEL, LOADING (SILVER) (GRX7)		* 9	4-996-728-81	CASE (BLACK) (R700)	
5	4-996-703-81	PANEL, LOADING (SILVER) (GRX7J)		10	1-773-048-11	WIRE (FLAT TYPE) (17 CORE)	
5	4-998-222-01	PANEL, LOADING (SILVER) (RX77: AEP, G, EE)		11	1-773-025-11	WIRE (FLAT TYPE) (15 CORE) (33CM)	

(2) FRONT PANEL SECTION

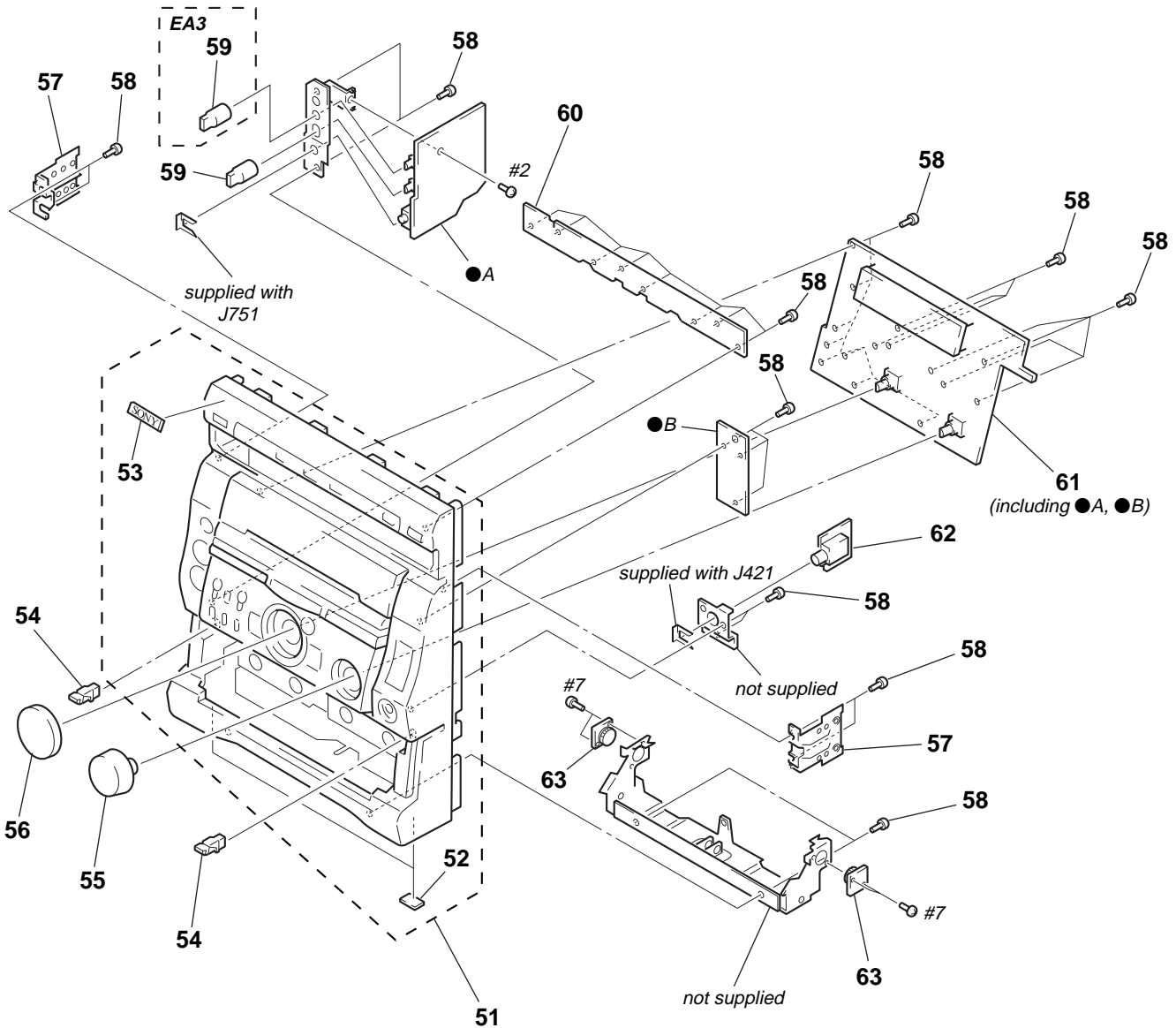

Ref. No.	Part No.	Description	Remark	Ref. No.	Part No.	Description	Remark
51	X-4949-343-1	PANEL ASSY, FRONT (SILVER) (RX77: AEP, G/RX77S: UK)		* 57	4-996-716-01	HOLDER (CDM)	
51	X-4949-385-1	PANEL ASSY, FRONT (SILVER) (EXCEPT AEP, UK, G, EE, CIS, EA3)		58	4-951-620-01	SCREW (2.6X8), +BVTP	
51	X-4949-386-1	PANEL ASSY, FRONT (SILVER) (EA3)		59	4-986-893-01	KNOB (MICROPHONE) (BLACK) (R700)	
51	X-4949-391-1	PANEL ASSY, FRONT (BLACK) (R700)		59	4-986-893-51	KNOB (MICROPHONE) (SILVER) (EXCEPT R700)	
51	X-4949-604-1	PANEL ASSY, FRONT (SILVER) (EE, CIS)		* 60	1-668-206-11	CD-SW BOARD	
52	4-930-336-61	FOOT (FELT)		* 61	A-4403-990-A	PANEL BOARD, COMPLETE (EE, CIS)	
53	4-962-708-11	EMBLEM (4-A), SONY		* 61	A-4407-013-A	PANEL BOARD, COMPLETE (EXCEPT AEP, UK, G, EE, CIS, EA3)	
54	4-995-081-01	LATCH, DC		* 61	A-4407-015-A	PANEL BOARD, COMPLETE (EA3)	
55	4-996-722-01	KNOB (VOL)		* 61	A-4407-998-A	PANEL BOARD, COMPLETE (AEP, UK, G)	
56	4-996-721-01	KNOB (JOG-U4)		* 62	1-668-209-11	HP BOARD	
				63	3-973-975-11	DAMPER, OIL	

(3) CHASSIS SECTION

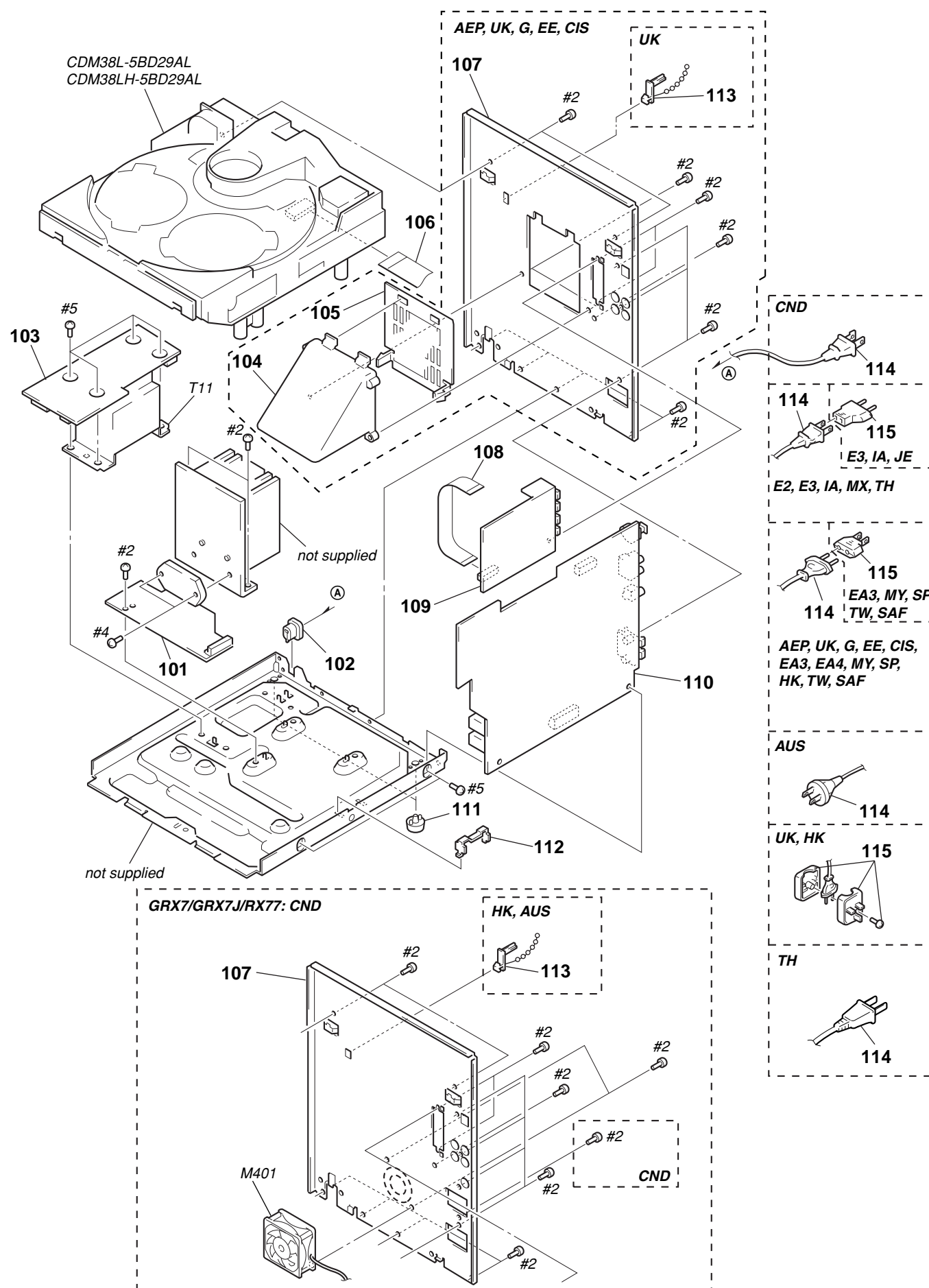

Ref. No.	Part No.	Description	Remark	Ref. No.	Part No.	Description	Remark
* 101	A-4403-998-A	POWER AMP BOARD, COMPLETE (AEP, UK, G, EE, CIS)		109	1-693-385-11	TUNER (JE)	
* 101	A-4407-010-A	POWER AMP BOARD, COMPLETE (EXCEPT CND, AEP, UK, G, EE, CIS)		* 109	A-4303-588-A	TCB BOARD, COMPLETE (EE, CIS)	
* 101	A-4407-027-A	POWER AMP BOARD, COMPLETE (CND)		* 109	A-4303-590-A	TCB BOARD, COMPLETE (AEP, UK, G)	
* 102	3-703-244-00	BUSHING (2104), CORD (CND, AEP, UK, G, EE, CIS, EA3, MY, SP, HK, TW, SAF, AUS)		* 110	A-4403-987-A	MAIN BOARD, COMPLETE (EE, CIS)	
102	3-703-571-11	BUSHING (S) (4516), CORD (E2, E3, EA4, TH, MX, JE)		* 110	A-4403-992-A	MAIN BOARD, COMPLETE (AEP, UK, G)	
				* 110	A-4407-007-A	MAIN BOARD, COMPLETE (GRX7: E3, EA3, MY, SP, HK, TW, SAF)	
				* 110	A-4407-017-A	MAIN BOARD, COMPLETE (E2, MX)	
* 103	1-668-208-11	TRANSFORMER BOARD		* 110	A-4407-021-A	MAIN BOARD, COMPLETE (AUS)	
104	4-996-736-01	DUCT (A) (AEP, UK, G, EE, CIS)		* 110	A-4407-024-A	MAIN BOARD, COMPLETE (CND)	
105	4-996-701-01	DUCT (B) (AEP, UK, G, EE, CIS)		* 110	A-4407-032-A	MAIN BOARD, COMPLETE (EA4, TH)	
106	1-783-570-11	WIRE (FLAT TYPE) (19 CORE) (24CM)		* 110	A-4407-040-A	MAIN BOARD, COMPLETE (IA)	
* 107	4-996-843-01	PANEL, BACK (CND)		* 110	A-4407-048-A	MAIN BOARD, COMPLETE (JE)	
* 107	4-996-843-61	PANEL, BACK (EA4, TH)		* 110	A-4407-056-A	MAIN BOARD, COMPLETE (GRX7J: EA3)	
* 107	4-996-844-01	PANEL, BACK (E2, E3)		111	4-965-822-01	FOOT	
* 107	4-996-844-11	PANEL, BACK (MY, SP, SAF)		* 112	4-988-533-01	HOLDER, PWB	
* 107	4-996-844-21	PANEL, BACK (GRX7: EA3, TW)		113	4-956-370-12	BAND, PLUG FIXED (UK, HK, AUS)	
* 107	4-996-844-31	PANEL, BACK (HK)		△ 114	1-575-651-11	CORD, POWER (EA3, EA4, MY, SP, HK, TW, SAF)	
* 107	4-996-844-41	PANEL, BACK (AUS)		△ 114	1-575-653-11	CORD, POWER (E2, E3, IA, MX, JE)	
* 107	4-996-844-51	PANEL, BACK (MX)		△ 114	1-690-608-11	CORD, POWER (AUS)	
* 107	4-996-844-71	PANEL, BACK (IA)		△ 114	1-690-609-21	CORD, POWER (CND)	
* 107	4-996-844-81	PANEL, BACK (GRX7J)		△ 114	1-751-326-31	CORD, POWER (TH)	
* 107	4-996-845-01	PANEL, BACK (RX77S: UK)		△ 114	1-775-787-71	CORD, POWER (AEP, UK, G, EE, CIS)	
* 107	4-996-845-11	PANEL, BACK (RX77S: EE, CIS)		△ 115	1-569-007-11	ADAPTOR, CONVERSION 2P (E3, IA, JE)	
* 107	4-996-845-21	PANEL, BACK (R700)		△ 115	1-569-008-11	ADAPTOR, CONVERSION 2P (EA3, MY, SP, TW, SAF)	
* 107	4-996-845-31	PANEL, BACK (RX77: AEP, G)		△ 115	1-770-019-11	ADAPTOR, CONVERSION PLUG 3P (UK, HK)	
* 107	4-996-845-41	PANEL, BACK (RX77: EE)		M401	1-698-792-11	FAN, DC (GRX7/GRX7J/RX77: CND)	
108	1-769-976-11	WIRE (FLAT TYPE) (13 CORE) (14CM) (CND, E2, EA4, TH, MX, AUS)		△ T11	1-431-659-11	TRANSFORMER, POWER (CND)	
108	1-773-008-11	WIRE (FLAT TYPE) (15 CORE) (14CM) (GRX7: E3, EA3, MY, SP, IA, HK, TW, SAF/GRX7J/R700/RX77: AEP, G, EE, RX77S)		△ T11	1-431-660-11	TRANSFORMER, POWER (AEP, UK, G, EE, CIS)	
109	1-233-544-11	ENCAPSULATED COMPONENT (CND)		△ T11	1-431-661-11	TRANSFORMER, POWER (GRX7/GRX7J)	
109	1-233-545-11	ENCAPSULATED COMPONENT (E2, EA4, TH, MX, AUS)		6	1-769-984-11	WIRE (FLAT TYPE) (13 CORE) (26CM)	
109	1-233-546-11	ENCAPSULATED COMPONENT (E3, EA3, MY, SP, IA, HK, TW, SAF)		10	1-773-048-11	WIRE (FLAT TYPE) (17 CORE)	
				11	1-773-025-11	WIRE (FLAT TYPE) (15 CORE) (33CM)	

The components identified by mark Δ or dotted line with mark Δ are critical for safety. Replace only with part number specified.

Les composants identifiés par une marque Δ sont critiques pour la sécurité. Ne les remplacer que par une pièce portant le numéro spécifié.

(4) CD MECHANISM DECK SECTION-1
(CDM38L-5BD29AL)
(CDM38LH-5BD29AL)

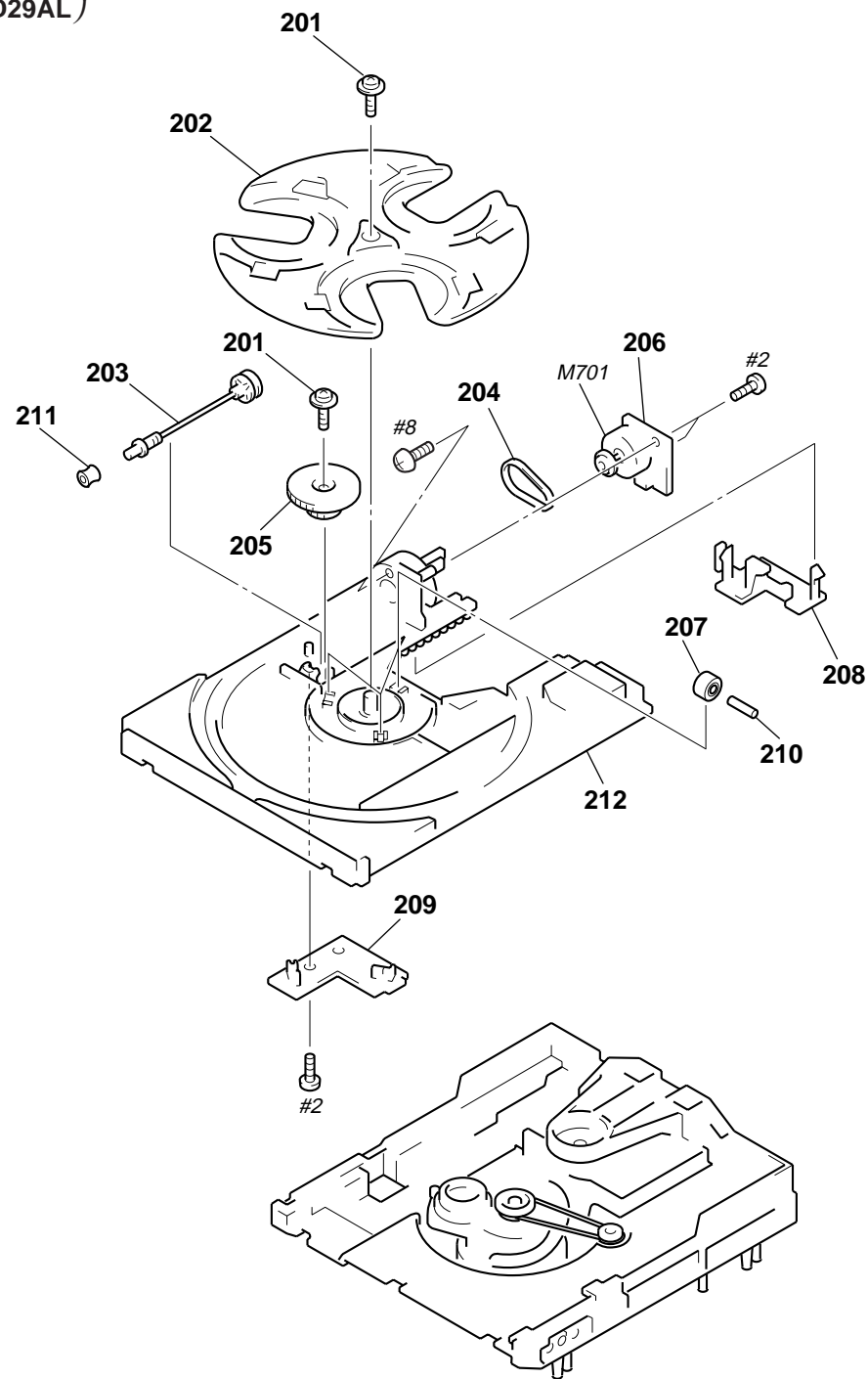

Ref. No.	Part No.	Description	Remark	Ref. No.	Part No.	Description	Remark
201	4-981-789-11	BRACKET (2), YOKE		208	4-977-941-01	BEARING (WORM)	
202	4-977-945-01	TRAY (TURN)		* 209	1-658-576-11	SENSOR BOARD	
203	X-4946-665-1	SHAFT ASSY, WORM		210	4-934-376-01	SHAFT (ROLLER)	
204	4-977-943-01	BELT (TURN) (1.2)		211	4-981-187-01	COLLAR (WORM)	
205	4-977-956-01	WHEEL, WORM		212	4-977-944-01	TRAY (SLIDE)	
* 206	1-658-577-11	MOTOR (TURN) BOARD		M701	A-4672-004-A	MOTOR ASSY (TURN)	
207	4-988-162-01	ROLLER					

(5) CD MECHANISM DECK SECTION-2
(CDM38L-5BD29AL)
(CDM38LH-5BD29AL)

HOW TO DISCRIMINATE
(MAGNET Ref.No.257,270)

FOR CDM38L
-5BD29AL

FOR CDM38LH
-5BD29AL

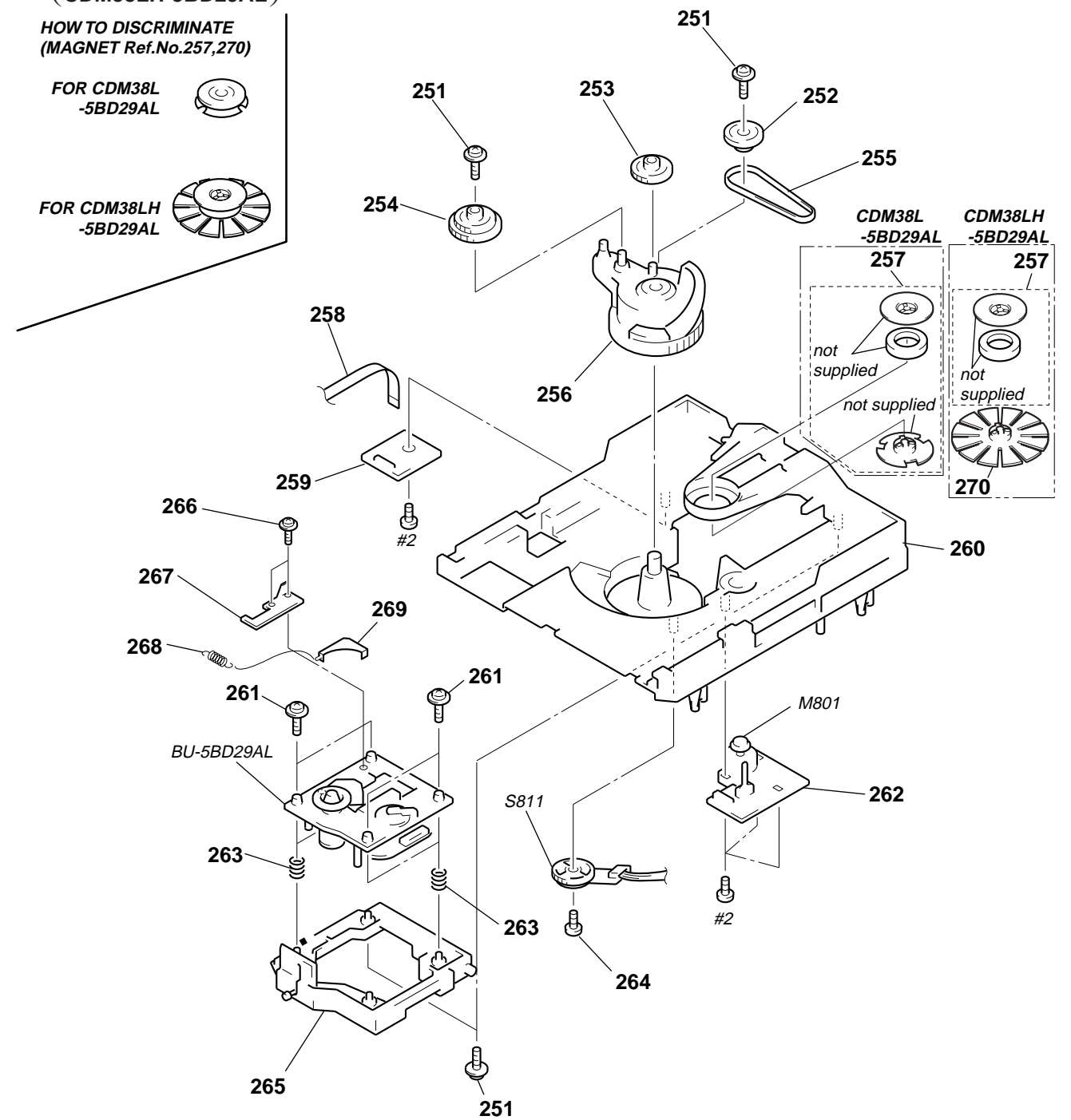

Ref. No.	Part No.	Description	Remark	Ref. No.	Part No.	Description	Remark
251	4-917-583-71	BRACKET, YOKE		* 262	1-658-578-11	MOTOR (SLIDE) BOARD	
252	4-977-954-01	PULLEY (SL)		263	4-982-447-01	SPRING (BU), COMPRESSION	
253	4-977-953-01	GEAR (SL-A)		264	4-951-620-41	SCREW (2.6), +BVTP	
254	4-977-955-01	GEAR (SL-B)		* 265	X-4946-666-1	HOLDER (BU) ASSY	
255	4-977-942-01	BELT (SL) (1.4)		266	4-989-494-01	SCREW (SLIDER), STEP	
256	X-4946-667-1	CAM ASSY, BU		267	4-989-492-11	SLIDER (38)	
* 257	1-452-879-11	MAGNET (CDM38L-5BD29AL)		268	4-989-819-02	SPRING, TENSION	
257	1-452-925-21	MAGNET ASSY (CDM38LH-5BD29AL)		269	4-989-491-21	COVER, LENS	
258	1-776-042-11	WIRE (FLAT TYPE) (8 CORE)		270	4-933-142-11	PULLEY (L), PRESS (CDM38LH-5BD29AL)	
* 259	1-658-575-11	CONNECTOR BOARD		M801	A-4672-004-A	MOTOR ASSY (SLIDE)	
* 260	X-4946-668-1	CHASSIS (CDM) ASSY		S811	1-473-335-11	ENCODER, ROTARY (BU, TRAY ADDRESS DET)	
261	4-985-672-01	SCREW (+PTPWH M2.6), FLOATING					

**(6) BASE UNIT SECTION
(BU-5BD29AL)**

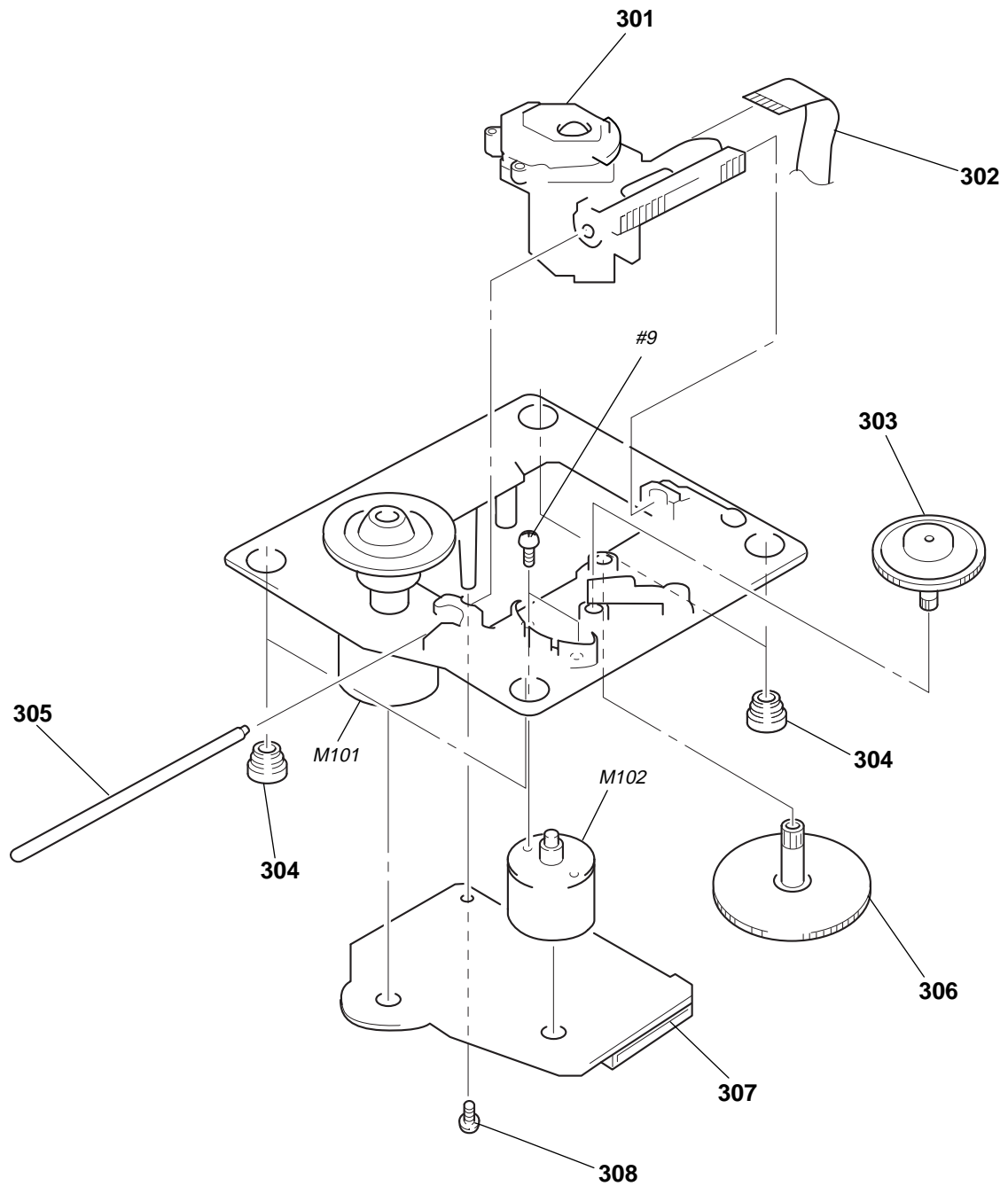

<p>The components identified by mark Δ or dotted line with mark Δ are critical for safety. Replace only with part number specified.</p>	<p>Les composants identifiés par une marque Δ sont critiques pour la sécurité. Ne les remplacer que par une pièce portant le numéro spécifié.</p>
---	---

Ref. No.	Part No.	Description	Remark	Ref. No.	Part No.	Description	Remark
Δ 301	8-820-020-02	OPTICAL PICK-UP KSS-213D/Q-NP		306	4-917-564-01	GEAR (P), FLATNESS	
302	1-769-069-11	WIRE (FLAT TYPE) (16 CORE)		* 307	A-4699-522-A	BD BOARD, COMPLETE	
303	4-917-567-21	GEAR (M)		308	4-951-620-01	SCREW (2.6X8), +BVTP	
304	4-951-940-01	INSULATOR (BU)		M101	X-4917-523-4	MOTOR ASSY (SPINDLE)	
305	4-917-565-01	SHAFT, SLED		M102	X-4917-504-1	MOTOR ASSY (SLED)	

(7) TAPE MECHANISM DECK SECTION-1
(TCM-230AWR1)
(TCM-230PWR1)

***NOTE:** Two types of parts which are not interchangeable are available for the Head deck (A) ASSY and Head deck (B) ASSY. When replacing the parts, refer to the following figure, and use the appropriate part

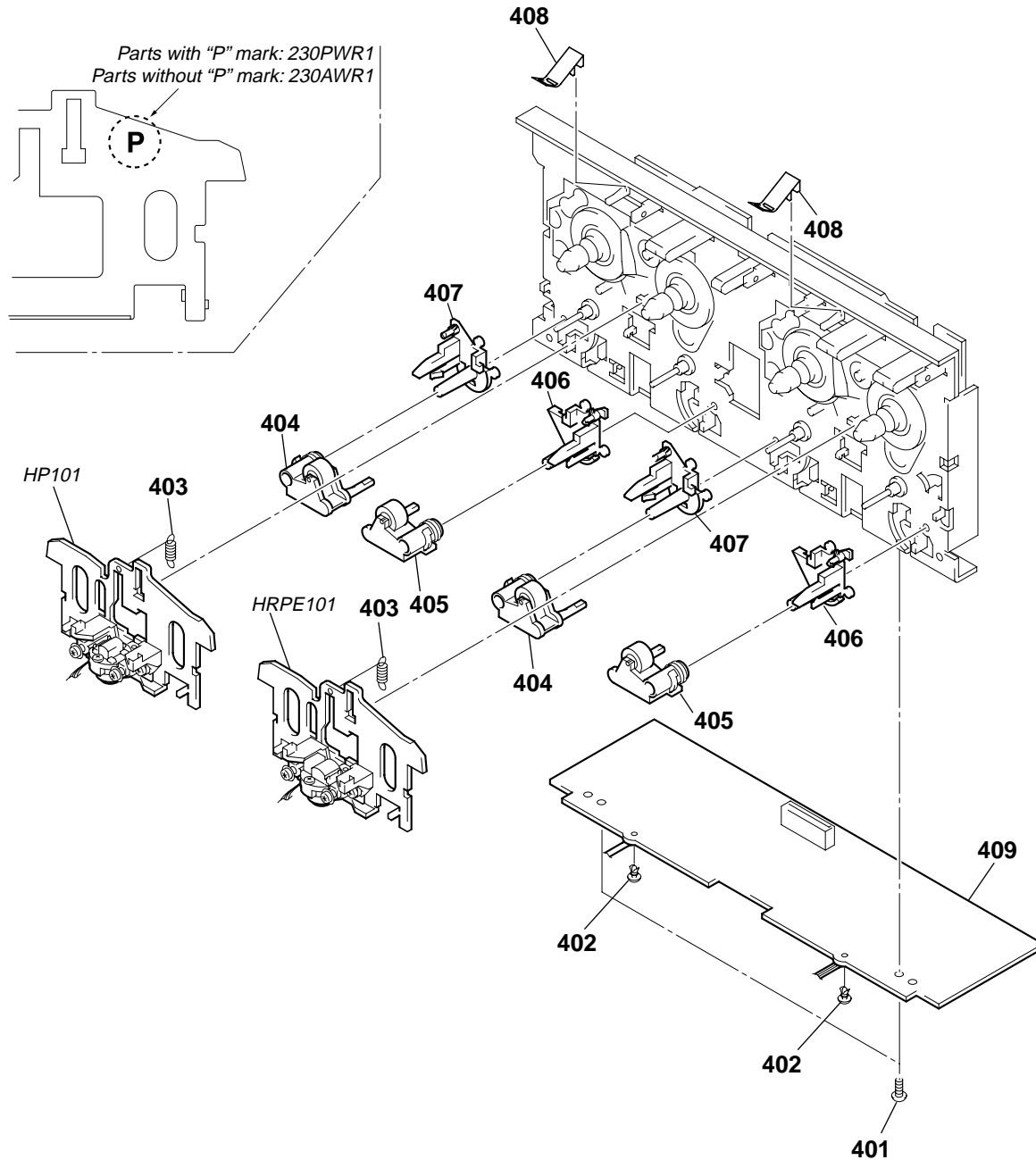

Ref. No.	Part No.	Description	Remark	Ref. No.	Part No.	Description	Remark
401	3-376-464-11	SCREW (+PTT 2.6X6), GROUND POINT		408	3-016-567-02	SPRING (CASSETTE), LEAF	
402	3-911-116-21	RIVET, PUSH		* 409	A-2007-731-A	AUDIO BOARD, COMPLETE	
403	3-016-574-01	SPRING (HEAD), TENSION		HP101	A-2056-681-A	DECK (A) ASSY, HEAD (230AWR1) (*NOTE)	
404	X-3374-156-2	PINCH LEVER (REV) ASSY		HRPE101A-2056-682-A	DECK (B) ASSY, HEAD (230AWR1) (*NOTE)		
405	X-3374-155-2	PINCH LEVER (FWD) ASSY					
406	3-016-564-01	BASE (PINCH LEVER FWD)		HRPE101A-2056-684-A	DECK (B) ASSY, HEAD (230PWR1) (*NOTE)		
407	3-016-565-01	BASE (PINCH LEVER REV)					

(8) TAPE MECHANISM DECK SECTION-2
(TCM-230AWR1)
(TCM-230PWR1)

***NOTE:** Two types of parts which are not interchangeable are available for the mechanical block assembly. When replacing the parts, refer to the following figure, and use the appropriate part.

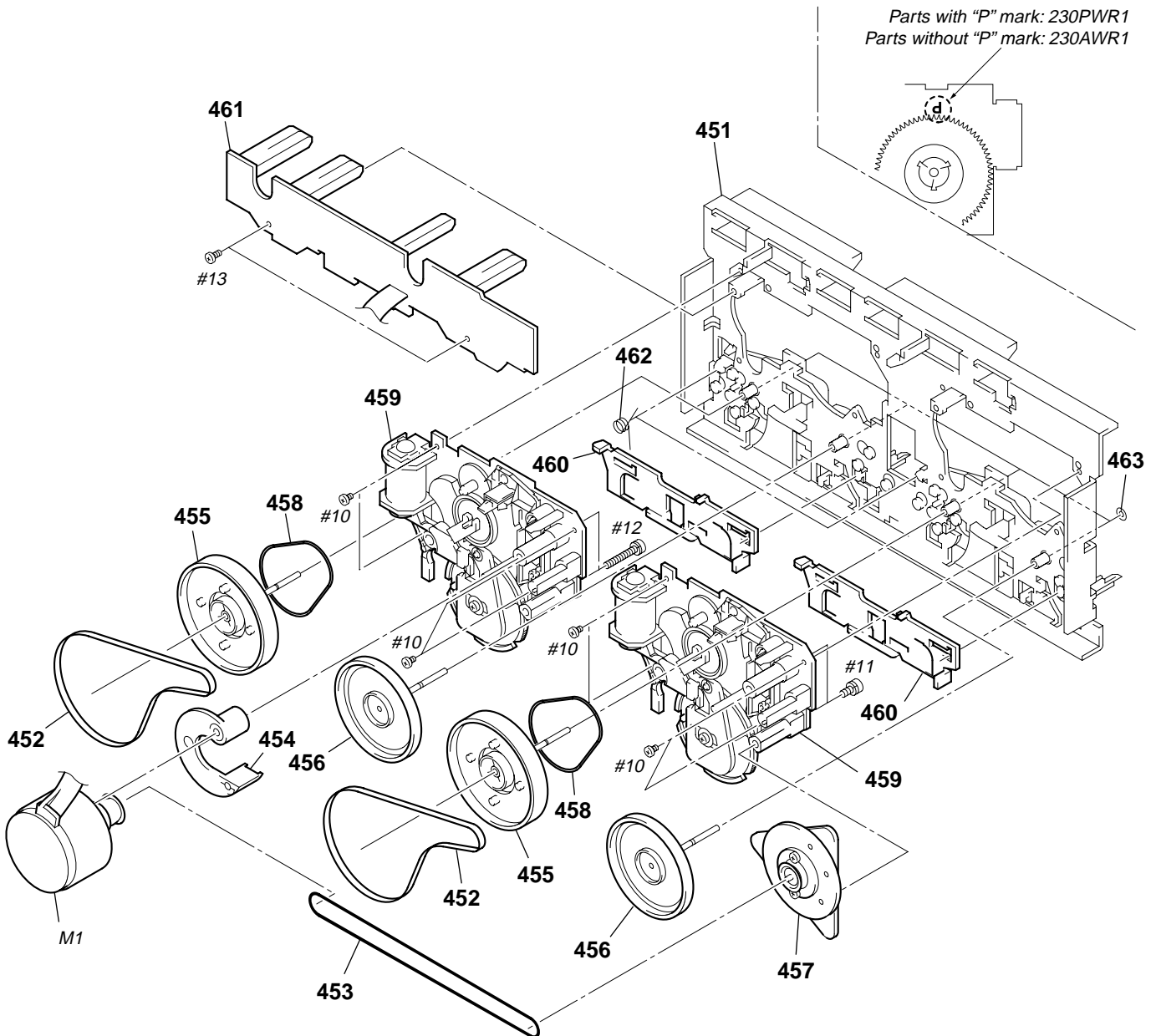

Ref. No.	Part No.	Description	Remark	Ref. No.	Part No.	Description	Remark
* 451	X-3374-214-1	CHASSIS ASSY, MAIN		459	A-2004-629-A	MECHANICAL BLOCK ASSY (230AWR1)	
452	3-016-570-01	BELT (CAPSTAN)		459	A-2004-630-A	MECHANICAL BLOCK ASSY (230PWR1)	(*NOTE)
453	3-016-569-01	BELT (TENSION)		460	3-016-566-01	SLIDER, REVERSE	
454	3-017-360-01	BRACKET (MOTOR)		* 461	A-2007-732-A	LEAF SW BOARD, COMPLETE	
455	X-3374-234-1	FLYWHEEL (FWD) ASSY		462	3-016-575-01	SPRING, TORSION	(*NOTE)
456	X-3374-235-1	FLYWHEEL (REV) ASSY		463	3-019-208-01	WASHER, STOPPER	
457	X-3374-238-1	PULLEY ASSY, TENSION		M1	A-2004-628-A	MOTOR ASSY, CAPSTAN	
458	3-024-405-01	BELT (FR)					

AUDIO

SECTION 9 ELECTRICAL PARTS LIST

NOTE:

- Due to standardization, replacements in the parts list may be different from the parts specified in the diagrams or the components used on the set.
- -XX and -X mean standardized parts, so they may have some difference from the original one.
- RESISTORS
All resistors are in ohms.
METAL: Metal-film resistor.
METAL OXIDE: Metal oxide-film resistor.
F: nonflammable
- Abbreviation
AUS : Australian IA : Indonesian
CND : Canadian JE : Tourist
E2 : 120V AC Area in E model MX : Mexican
E3 : 240V AC Area in E model MY : Malaysia
EA3 : Saudi Arabia SAF : South African
EA4 : Israel SP : Singapore
EE : East European TH : Thai
G : German TW : Taiwan
HK : Hong Kong

- Items marked “**” are not stocked since they are seldom required for routine service. Some delay should be anticipated when ordering these items.
- SEMICONDUCTORS
In each case, u: μ , for example:
uA. . . : μ A. . . uPA. . . : μ PA. . .
uPB. . . : μ PB. . . uPC. . . : μ PC. . .
uPD. . . : μ PD. . .
- CAPACITORS
uF: μ F
- COILS
uH: μ H

The components identified by mark Δ or dotted line with mark Δ are critical for safety. Replace only with part number specified.

Les composants identifiés par une marque Δ sont critiques pour la sécurité. Ne les remplacer que par une pièce portant le numéro spécifié.

When indicating parts by reference number, please include the board.

Ref. No.	Part No.	Description	Remark	Ref. No.	Part No.	Description	Remark
*	A-2007-731-A	AUDIO BOARD, COMPLETE *****		C642	1-104-664-11	ELECT 47uF 20% 16V	
		< CAPACITOR >				< CONNECTOR >	
C301	1-162-289-31	CERAMIC 390PF 10% 50V		CN601	1-695-338-11	PIN, CONNECTOR (PC BOARD) 15P	
C302	1-126-968-11	ELECT 100uF 20% 6.3V				< IC >	
C303	1-162-282-31	CERAMIC 100PF 10% 50V		IC601	8-759-111-44	IC UPC4570C-1	
C304	1-130-483-00	MYLAR 0.01uF 5% 50V		IC602	8-759-143-54	IC UPC1330HA	
C305	1-107-715-11	ELECT 22uF 20% 16V		IC611	8-759-111-44	IC UPC4570C-1	
C311	1-162-289-31	CERAMIC 390PF 10% 50V				< COIL >	
C313	1-162-282-31	CERAMIC 100PF 10% 50V		L331	1-410-780-11	INDUCTOR 27mH	
C314	1-130-487-00	MYLAR 0.022uF 5% 50V		L431	1-410-780-11	INDUCTOR 27mH	
C315	1-126-233-11	ELECT 22uF 20% 50V		L601	1-414-193-41	INDUCTOR, MICRO 22uH	
C331	1-137-427-11	FILM 120PF 5% 50V		L602	1-414-193-41	INDUCTOR, MICRO 22uH	
C332	1-162-288-31	CERAMIC 330PF 10% 50V				< TRANSISTOR >	
C333	1-162-209-31	CERAMIC 27PF 5% 50V		Q621	8-729-142-46	TRANSISTOR 2SC2001-LK	
C401	1-162-289-31	CERAMIC 390PF 10% 50V		Q622	8-729-142-46	TRANSISTOR 2SC2001-LK	
C402	1-126-968-11	ELECT 100uF 20% 6.3V		Q623	8-729-801-93	TRANSISTOR 2SD1387	
C403	1-162-282-31	CERAMIC 100PF 10% 50V				< RESISTOR >	
C404	1-130-483-00	MYLAR 0.01uF 5% 50V		R301	1-247-881-00	CARBON 120K 5% 1/4W	
C405	1-107-715-11	ELECT 22uF 20% 16V		R302	1-249-409-11	CARBON 220 5% 1/4W	
C411	1-162-289-31	CERAMIC 390PF 10% 50V		R303	1-249-433-11	CARBON 22K 5% 1/4W	
C413	1-162-282-31	CERAMIC 100PF 10% 50V		R304	1-247-889-00	CARBON 270K 5% 1/4W	
C414	1-130-487-00	MYLAR 0.022uF 5% 50V		R305	1-247-858-11	CARBON 13K 5% 1/4W	
C415	1-126-233-11	ELECT 22uF 20% 50V		R311	1-247-881-00	CARBON 120K 5% 1/4W	
C431	1-137-427-11	FILM 120PF 5% 50V		R312	1-247-807-31	CARBON 100 5% 1/4W	
C432	1-162-288-31	CERAMIC 330PF 10% 50V		R314	1-247-882-11	CARBON 130K 5% 1/4W	
C433	1-162-209-31	CERAMIC 27PF 5% 50V		R315	1-247-850-11	CARBON 6.2K 5% 1/4W	
C601	1-104-396-11	ELECT 10uF 20% 16V		R331	1-249-430-11	CARBON 12K 5% 1/4W	
C602	1-104-396-11	ELECT 10uF 20% 16V		R401	1-247-881-00	CARBON 120K 5% 1/4W	
C611	1-104-396-11	ELECT 10uF 20% 16V		R402	1-249-409-11	CARBON 220 5% 1/4W	
C612	1-104-396-11	ELECT 10uF 20% 16V		R403	1-249-433-11	CARBON 22K 5% 1/4W	
C621	1-137-150-11	FILM 0.01uF 5% 100V		R404	1-247-889-00	CARBON 270K 5% 1/4W	
C622	1-126-961-11	ELECT 2.2uF 20% 50V		R405	1-247-858-11	CARBON 13K 5% 1/4W	
C623	1-136-155-00	FILM 0.015uF 5% 50V		R411	1-247-881-00	CARBON 120K 5% 1/4W	
C624	1-130-481-00	MYLAR 0.0068uF 5% 50V					
C625	1-130-481-00	MYLAR 0.0068uF 5% 50V					
C627	1-124-903-11	ELECT 1uF 20% 50V					
C628	1-136-153-00	FILM 0.01uF 5% 50V					

Ref. No.	Part No.	Description	Remark	Ref. No.	Part No.	Description	Remark
R412	1-247-807-31	CARBON	100 5% 1/4W	C127	1-164-161-11	CERAMIC CHIP 0.0022uF 10%	100V
R414	1-247-882-11	CARBON	130K 5% 1/4W	C128	1-163-135-00	CERAMIC CHIP 560PF 5%	50V
R415	1-247-850-11	CARBON	6.2K 5% 1/4W	C129	1-163-038-91	CERAMIC CHIP 0.1uF	25V
R431	1-249-430-11	CARBON	12K 5% 1/4W	C130	1-164-336-11	CERAMIC CHIP 0.33uF	25V
R601	1-249-409-11	CARBON	220 5% 1/4W	C131	1-164-346-11	CERAMIC CHIP 1uF	16V
R602	1-249-409-11	CARBON	220 5% 1/4W	C140	1-110-501-11	CERAMIC CHIP 0.33uF 10%	16V
R608	1-249-409-11	CARBON	220 5% 1/4W	C154	1-163-235-11	CERAMIC CHIP 22PF 5%	50V
R609	1-249-433-11	CARBON	22K 5% 1/4W	C161	1-164-005-11	CERAMIC CHIP 0.47uF	25V
R611	1-249-409-11	CARBON	220 5% 1/4W	C162	1-164-232-11	CERAMIC CHIP 0.01uF	50V
R612	1-249-409-11	CARBON	220 5% 1/4W	C163	1-163-117-00	CERAMIC CHIP 100PF 5%	50V
△R621	1-212-851-00	FUSIBLE	5.6 5% 1/4W F	C164	1-163-145-00	CERAMIC CHIP 0.0015uF 5%	50V
△R622	1-212-851-00	FUSIBLE	5.6 5% 1/4W F	C165	1-164-004-11	CERAMIC CHIP 0.1uF 10%	25V
R623	1-249-432-11	CARBON	18K 5% 1/4W	C166	1-163-137-00	CERAMIC CHIP 680PF 5%	50V
R624	1-249-432-11	CARBON	18K 5% 1/4W	C167	1-163-121-00	CERAMIC CHIP 150PF 5%	50V
R625	1-249-429-11	CARBON	10K 5% 1/4W	C168	1-163-137-00	CERAMIC CHIP 680PF 5%	50V
		< VARIABLE RESISTOR >		C169	1-163-121-00	CERAMIC CHIP 150PF 5%	50V
RV301	1-238-598-11	RES, ADJ, CARBON 2.2K		C170	1-163-099-00	CERAMIC CHIP 18PF 5%	50V
RV311	1-238-598-11	RES, ADJ, CARBON 2.2K		C171	1-163-237-11	CERAMIC CHIP 27PF 5%	50V
RV341	1-241-768-11	RES, ADJ, CARBON 220K		C173	1-163-038-91	CERAMIC CHIP 0.1uF	25V
RV401	1-238-598-11	RES, ADJ, CARBON 2.2K		C174	1-163-038-91	CERAMIC CHIP 0.1uF	25V
RV411	1-238-598-11	RES, ADJ, CARBON 2.2K		C175	1-163-038-91	CERAMIC CHIP 0.1uF	25V
RV441	1-241-768-11	RES, ADJ, CARBON 220K		C176	1-163-038-91	CERAMIC CHIP 0.1uF	25V
		< TRANSFORMER >		C177	1-163-038-91	CERAMIC CHIP 0.1uF	25V
T621	1-423-980-11	TRANSFORMER, BIAS OSCILLATION		C178	1-163-038-91	CERAMIC CHIP 0.1uF	25V
		*****		C179	1-163-038-91	CERAMIC CHIP 0.1uF	25V
*	A-4699-522-A	BD BOARD, COMPLETE		C181	1-126-205-11	ELECT CHIP 47uF 20%	6.3V
		*****		C182	1-126-393-11	ELECT CHIP 33uF 20%	10V
		< CAPACITOR >		C183	1-124-778-00	ELECT CHIP 22uF 20%	6.3V
C101	1-126-607-11	ELECT CHIP 47uF 20%	4V	C185	1-164-232-11	CERAMIC CHIP 0.01uF	50V
C102	1-163-141-00	CERAMIC CHIP 0.001uF 5%	50V	C188	1-163-235-11	CERAMIC CHIP 22PF 5%	50V
C103	1-164-346-11	CERAMIC CHIP 1uF	16V	C189	1-163-235-11	CERAMIC CHIP 22PF 5%	50V
C105	1-163-038-91	CERAMIC CHIP 0.1uF	25V			< CONNECTOR >	
C106	1-164-161-11	CERAMIC CHIP 0.0022uF 10%	100V	CNU101	1-770-014-11	CONNECTOR, FFC/FPC 16P	
C107	1-164-161-11	CERAMIC CHIP 0.0022uF 10%	100V	CNU102	1-778-874-11	CONNECTOR, FFC (LIF (NON-ZIF)) 19P	
C108	1-164-232-11	CERAMIC CHIP 0.01uF	50V			< FERRITE BEAD >	
C109	1-164-232-11	CERAMIC CHIP 0.01uF	50V	FB101	1-414-234-11	INDUCTOR CHIP 0UH	
C110	1-163-989-11	CERAMIC CHIP 0.033uF 10%	25V	FB103	1-414-234-11	INDUCTOR CHIP 0UH	
C111	1-163-017-00	CERAMIC CHIP 0.0047uF 5%	50V			< IC >	
C112	1-163-017-00	CERAMIC CHIP 0.0047uF 5%	50V	IC101	8-752-080-62	IC CXA1992AR	
C113	1-164-161-11	CERAMIC CHIP 0.0022uF 10%	100V	IC102	8-759-429-32	IC BA5941FP-E2	
C114	1-164-005-11	CERAMIC CHIP 0.47uF	25V	IC103	8-752-378-66	IC CXD2519Q	
C115	1-126-607-11	ELECT CHIP 47uF 20%	4V			< JUMPER RESISTOR >	
C116	1-163-016-00	CERAMIC CHIP 0.0039uF 10%	50V	JW101	1-216-295-91	SHORT 0	
C117	1-164-005-11	CERAMIC CHIP 0.47uF	25V	JW104	1-216-295-91	SHORT 0	
C118	1-164-004-11	CERAMIC CHIP 0.1uF 10%	25V			< TRANSISTOR >	
C119	1-163-038-91	CERAMIC CHIP 0.1uF	25V	Q101	8-729-010-08	TRANSISTOR MSB710-R	
C120	1-124-779-00	ELECT CHIP 10uF 20%	16V			< RESISTOR >	
C121	1-163-038-91	CERAMIC CHIP 0.1uF	25V	R102	1-216-001-00	METAL CHIP 10 5%	1/10W
C122	1-164-232-11	CERAMIC CHIP 0.01uF	50V	R104	1-216-093-00	METAL CHIP 68K 5%	1/10W
C123	1-163-038-91	CERAMIC CHIP 0.1uF	25V	R105	1-216-088-00	METAL CHIP 43K 5%	1/10W
C124	1-126-607-11	ELECT CHIP 47uF 20%	4V	R106	1-216-088-00	METAL CHIP 43K 5%	1/10W
C125	1-164-232-11	CERAMIC CHIP 0.01uF	50V				
C126	1-163-038-91	CERAMIC CHIP 0.1uF	25V				

The components identified by mark △ or dotted line with mark △ are critical for safety. Replace only with part number specified.

Les composants identifiés par une marque △ sont critiques pour la sécurité. Ne les remplacer que par une pièce portant le numéro spécifié.

BD	CD-SW	CONNECTOR
-----------	--------------	------------------

Ref. No.	Part No.	Description	Remark
R107	1-216-088-00	METAL CHIP 43K 5%	1/10W
R108	1-216-088-00	METAL CHIP 43K 5%	1/10W
R109	1-216-093-00	METAL CHIP 68K 5%	1/10W
R114	1-216-101-00	METAL CHIP 150K 5%	1/10W
R115	1-216-101-00	METAL CHIP 150K 5%	1/10W
R116	1-216-061-00	METAL CHIP 3.3K 5%	1/10W
R117	1-216-069-00	METAL CHIP 6.8K 5%	1/10W
R118	1-216-063-91	RES, CHIP 3.9K 5%	1/10W
R119	1-216-085-00	METAL CHIP 33K 5%	1/10W
R120	1-216-089-91	RES, CHIP 47K 5%	1/10W
R121	1-216-114-00	RES, CHIP 510K 5%	1/10W
R122	1-216-097-91	RES, CHIP 100K 5%	1/10W
R123	1-216-099-00	METAL CHIP 120K 5%	1/10W
R124	1-216-091-00	METAL CHIP 56K 5%	1/10W
R125	1-216-069-00	METAL CHIP 6.8K 5%	1/10W
R126	1-216-063-91	RES, CHIP 3.9K 5%	1/10W
R127	1-216-089-91	RES, CHIP 47K 5%	1/10W
R128	1-216-098-00	METAL CHIP 110K 5%	1/10W
R129	1-216-025-91	RES, CHIP 100 5%	1/10W
R130	1-216-079-00	METAL CHIP 18K 5%	1/10W
R131	1-216-079-00	METAL CHIP 18K 5%	1/10W
R132	1-216-061-00	METAL CHIP 3.3K 5%	1/10W
R133	1-216-061-00	METAL CHIP 3.3K 5%	1/10W
R134	1-216-065-00	METAL CHIP 4.7K 5%	1/10W
R135	1-216-065-00	METAL CHIP 4.7K 5%	1/10W
R136	1-216-073-00	METAL CHIP 10K 5%	1/10W
R137	1-216-065-00	METAL CHIP 4.7K 5%	1/10W
R138	1-216-025-91	RES, CHIP 100 5%	1/10W
R156	1-216-081-00	METAL CHIP 22K 5%	1/10W
R157	1-216-069-00	METAL CHIP 6.8K 5%	1/10W
R158	1-216-001-00	METAL CHIP 10 5%	1/10W
R159	1-216-121-91	RES, CHIP 1M 5%	1/10W
R161	1-216-097-91	RES, CHIP 100K 5%	1/10W
R162	1-216-073-00	METAL CHIP 10K 5%	1/10W
R163	1-216-121-91	RES, CHIP 1M 5%	1/10W
R164	1-216-061-00	METAL CHIP 3.3K 5%	1/10W
R165	1-216-049-91	RES, CHIP 1K 5%	1/10W
R166	1-216-073-00	METAL CHIP 10K 5%	1/10W
R167	1-216-081-00	METAL CHIP 22K 5%	1/10W
R168	1-216-073-00	METAL CHIP 10K 5%	1/10W
R169	1-216-079-00	METAL CHIP 18K 5%	1/10W
R170	1-216-081-00	METAL CHIP 22K 5%	1/10W
R171	1-216-073-00	METAL CHIP 10K 5%	1/10W
R172	1-216-079-00	METAL CHIP 18K 5%	1/10W
R173	1-216-025-91	RES, CHIP 100 5%	1/10W
R174	1-216-033-00	METAL CHIP 220 5%	1/10W
R175	1-216-025-91	RES, CHIP 100 5%	1/10W
R176	1-216-025-91	RES, CHIP 100 5%	1/10W
R177	1-216-025-91	RES, CHIP 100 5%	1/10W
R178	1-216-025-91	RES, CHIP 100 5%	1/10W
R179	1-216-025-91	RES, CHIP 100 5%	1/10W
R180	1-216-025-91	RES, CHIP 100 5%	1/10W
R181	1-216-025-91	RES, CHIP 100 5%	1/10W
R188	1-216-037-00	METAL CHIP 330 5%	1/10W
R190	1-216-097-91	RES, CHIP 100K 5%	1/10W
R191	1-216-105-91	RES, CHIP 220K 5%	1/10W

Ref. No.	Part No.	Description	Remark
		< SWITCH >	
S101	1-572-085-11	SWITCH, LEAF (LIMIT)	
		< VIBRATOR >	
X101	1-767-408-21	VIBRATOR, CRYSTAL (16.9344MHz)	

*	1-668-206-11	CD-SW BOARD	

		< DIODE >	
D631	8-719-056-13	LED SML79423C-TP15 (DISC 1)	
D632	8-719-056-13	LED SML79423C-TP15 (DISC 2)	
D633	8-719-056-13	LED SML79423C-TP15 (DISC 3)	
		< TRANSISTOR >	
Q613	8-729-029-68	TRANSISTOR DTC114TSA	
Q614	8-729-029-68	TRANSISTOR DTC114TSA	
Q615	8-729-029-68	TRANSISTOR DTC114TSA	
		< RESISTOR >	
R656	1-249-418-11	CARBON 1.2K 5%	1/4W
R657	1-249-419-11	CARBON 1.5K 5%	1/4W
R658	1-249-421-11	CARBON 2.2K 5%	1/4W
R659	1-247-843-11	CARBON 3.3K 5%	1/4W
R660	1-249-425-11	CARBON 4.7K 5%	1/4W
R691	1-247-804-11	CARBON 75 5%	1/4W
R692	1-247-804-11	CARBON 75 5%	1/4W
R693	1-247-804-11	CARBON 75 5%	1/4W
R694	1-247-804-11	CARBON 75 5%	1/4W
R695	1-247-804-11	CARBON 75 5%	1/4W
R696	1-247-804-11	CARBON 75 5%	1/4W
		< SWITCH >	
S637	1-771-410-11	SWITCH, KEYBOARD (I/⏻ (POWER))	
S638	1-771-410-11	SWITCH, KEYBOARD (DISC 1)	
S639	1-771-410-11	SWITCH, KEYBOARD (DISC 2)	
S640	1-771-410-11	SWITCH, KEYBOARD (DISC 3)	
S641	1-771-410-11	SWITCH, KEYBOARD (DISC SKIP/EX-CHANGE)	
S642	1-771-410-11	SWITCH, KEYBOARD (⏻)	

*	1-658-575-11	CONNECTOR BOARD	

		< CONNECTOR >	
* CN701	1-568-946-11	PIN, CONNECTOR 8P	
CN702	1-750-413-11	CONNECTOR, FFC/FPC 8P	
		< TRANSISTOR >	
Q701	8-729-900-80	TRANSISTOR DTC114ES	
		< RESISTOR >	
R703	1-249-435-11	CARBON 33K 5%	1/4W
R704	1-249-429-11	CARBON 10K 5%	1/4W
R705	1-249-417-11	CARBON 1K 5%	1/4W

Ref. No.	Part No.	Description	Remark
*	1-668-209-11	HP BOARD *****	
		< CAPACITOR >	
C421	1-162-294-31	CERAMIC 0.001uF 10% 50V	
C471	1-162-294-31	CERAMIC 0.001uF 10% 50V	
C472	1-164-159-11	CERAMIC 0.1uF 50V	
		< CONNECTOR >	
* CN109	1-564-521-11	PLUG, CONNECTOR 6P	
		< LEAD >	
EL1	1-690-880-41	LEAD (WITH CONNECTOR)	
		< JACK >	
J421	1-784-224-11	JACK (LARGE TYPE) (PHONES) (GRX7/GRX7J/RX77/RX77S)	
J421	1-784-900-11	JACK (LARGE TYPE) (PHONES) (R700)	

*	A-2007-732-A	LEAF SW BOARD, COMPLETE *****	
		< CAPACITOR >	
C1001	1-128-124-11	ELECT 33uF 20% 10V	
		< CONNECTOR >	
CN1001	1-568-860-11	SOCKET, CONNECTOR 17P	
CN1001	1-784-459-11	CONNECTOR, FFC/FPC 17P	
		< DIODE >	
D1001	8-719-911-19	DIODE 1SS119	
D1002	8-719-911-19	DIODE 1SS119	
		< CONNECTOR >	
* DM1001	1-784-581-11	HOLDER, CABLE (2.5MM PITCH) 4P	
		< IC >	
IC1001	8-749-014-38	IC PHOTO INTERRUPTER SG-264	
IC1002	8-749-014-38	IC PHOTO INTERRUPTER SG-264	
		< TRANSISTOR >	
Q1001	8-729-029-56	TRANSISTOR DTA144ESA	
Q1001	8-729-900-65	TRANSISTOR DTA144ES	
		< RESISTOR >	
R907	1-247-879-11	CARBON 100K 5% 1/4W	
R1001	1-249-409-11	CARBON 220 5% 1/4W	
R1002	1-249-409-11	CARBON 220 5% 1/4W	
R1003	1-249-414-11	CARBON 560 5% 1/4W	
R1004	1-247-834-11	CARBON 1.3K 5% 1/4W	
R1005	1-247-818-11	CARBON 300 5% 1/4W	
R1006	1-247-864-11	CARBON 24K 5% 1/4W	
R1007	1-247-856-00	CARBON 11K 5% 1/4W	
R1008	1-249-417-11	CARBON 1K 5% 1/4W	

Ref. No.	Part No.	Description	Remark
		< VARIABLE RESISTOR >	
RV1001	1-241-785-11	RES, ADJ, CARBON 10K	
RV1002	1-241-785-11	RES, ADJ, CARBON 10K	
		< SWITCH >	
S1001	1-570-953-11	SWITCH, PUSH (1 KEY) (A PLAY)	
S1002	1-570-953-11	SWITCH, PUSH (1 KEY) (B PLAY)	
S1003	1-771-333-11	SWITCH, LEAF (A HALF)	
S1004	1-771-205-11	SWITCH, LEAF (A 1/20/70)	
S1005	1-771-205-11	SWITCH, LEAF (REC A)	
S1006	1-771-333-11	SWITCH, LEAF (B HALF)	
S1008	1-771-205-11	SWITCH, LEAF (B 1/20/70)	
S1009	1-771-205-11	SWITCH, LEAF (REC B)	

*	A-4403-987-A	MAIN BOARD, COMPLETE (EE, CIS)	
*	A-4403-992-A	MAIN BOARD, COMPLETE (AEP, UK, G)	
*	A-4407-007-A	MAIN BOARD, COMPLETE (GRX7: E3, EA3, MY, SP, HK, TW, SAF)	
*	A-4407-017-A	MAIN BOARD, COMPLETE (E2, MX)	
*	A-4407-021-A	MAIN BOARD, COMPLETE (AUS)	
*	A-4407-024-A	MAIN BOARD, COMPLETE (CND)	
*	A-4407-032-A	MAIN BOARD, COMPLETE (EA4, TH)	
*	A-4407-040-A	MAIN BOARD, COMPLETE (IA)	
*	A-4407-048-A	MAIN BOARD, COMPLETE (JE)	
*	A-4407-056-A	MAIN BOARD, COMPLETE (GRX7J: EA3) *****	
		< CAPACITOR >	
C101	1-162-286-31	CERAMIC 220PF 10% 50V	
C102	1-162-286-31	CERAMIC 220PF 10% 50V	
C103	1-164-159-11	CERAMIC 0.1uF 50V	
C111	1-137-195-11	FILM 0.56uF 5% 50V	
C112	1-136-158-00	FILM 0.027uF 5% 50V	
C113	1-136-167-00	FILM 0.15uF 5% 50V (GRX7/GRX7J/RX77: CND)	
C114	1-130-480-00	MYLAR 0.0056uF 5% 50V (GRX7/GRX7J/RX77: CND)	
C115	1-136-159-00	FILM 0.033uF 5% 50V	
C116	1-130-473-00	MYLAR 0.0015uF 5% 50V	
C117	1-136-153-00	FILM 0.01uF 5% 50V (GRX7/GRX7J/RX77: CND)	
C118	1-110-341-11	MYLAR 330PF 5% 50V (GRX7/GRX7J/RX77: CND)	
C119	1-130-479-00	MYLAR 0.0047uF 5% 50V	
C120	1-130-477-00	MYLAR 0.0033uF 5% 50V	
C121	1-126-964-11	ELECT 10uF 20% 50V	
C122	1-162-291-31	CERAMIC 560PF 10% 50V	
C123	1-136-165-00	FILM 0.1uF 5% 50V	
C124	1-136-165-00	FILM 0.1uF 5% 50V	
C125	1-126-964-11	ELECT 10uF 20% 50V	
C131	1-126-967-11	ELECT 47uF 20% 16V	
C132	1-126-967-11	ELECT 47uF 20% 16V	
C133	1-164-159-11	CERAMIC 0.1uF 50V	
C134	1-164-159-11	CERAMIC 0.1uF 50V	
C135	1-126-964-11	ELECT 10uF 20% 50V	
C136	1-164-159-11	CERAMIC 0.1uF 50V	

MAIN

Ref. No.	Part No.	Description	Remark			Ref. No.	Part No.	Description	Remark		
C141	1-126-959-11	ELECT	0.47uF	20%	50V	C334	1-162-600-11	CERAMIC	0.0047uF	20%	16V
C151	1-162-286-31	CERAMIC	220PF	10%	50V	C351	1-126-160-11	ELECT	1uF	20%	50V
C152	1-162-286-31	CERAMIC	220PF	10%	50V	C352	1-130-479-00	MYLAR	0.0047uF	5%	50V
C161	1-137-195-11	FILM	0.56uF	5%	50V	C353	1-136-165-00	FILM	0.1uF	5%	50V
C162	1-136-158-00	FILM	0.027uF	5%	50V	C354	1-136-165-00	FILM	0.1uF	5%	50V
C163	1-136-167-00	FILM	0.15uF	5%	50V	C355	1-126-956-91	ELECT	0.1uF	20%	50V
			(GRX7/GRX7J/RX77: CND)						(AEP, UK, G, EE, CIS)		
C164	1-130-480-00	MYLAR	0.0056uF	5%	50V	C355	1-126-964-11	ELECT	10uF	20%	50V
			(GRX7/GRX7J/RX77: CND)						(GRX7/GRX7J/RX77: CND)		
C165	1-136-159-00	FILM	0.033uF	5%	50V	C356	1-126-160-11	ELECT	1uF	20%	50V
C166	1-130-473-00	MYLAR	0.0015uF	5%	50V	C357	1-126-959-11	ELECT	0.47uF	20%	50V
C167	1-136-153-00	FILM	0.01uF	5%	50V	C358	1-126-964-11	ELECT	10uF	20%	50V
			(GRX7/GRX7J/RX77: CND)			C359	1-136-173-00	FILM	0.47uF	5%	50V
C168	1-110-341-11	MYLAR	330PF	5%	50V	C381	1-162-306-11	CERAMIC	0.01uF	20%	16V
			(GRX7/GRX7J/RX77: CND)			C382	1-126-933-11	ELECT	100uF	20%	10V
C169	1-130-479-00	MYLAR	0.0047uF	5%	50V	C391	1-164-159-11	CERAMIC	0.1uF		50V
C170	1-130-477-00	MYLAR	0.0033uF	5%	50V	C392	1-126-916-11	ELECT	1000uF	20%	6.3V
C171	1-126-964-11	ELECT	10uF	20%	50V	C393	1-164-159-11	CERAMIC	0.1uF		50V
C172	1-162-291-31	CERAMIC	560PF	10%	50V	C394	1-126-925-11	ELECT	470uF	20%	10V
C173	1-136-165-00	FILM	0.1uF	5%	50V	C395	1-162-290-31	CERAMIC	470PF	10%	50V
C174	1-136-165-00	FILM	0.1uF	5%	50V	C396	1-126-961-11	ELECT	2.2uF	20%	50V
C175	1-126-964-11	ELECT	10uF	20%	50V	C397	1-126-961-11	ELECT	2.2uF	20%	50V
C176	1-136-495-11	FILM	0.068uF	5%	50V	C401	1-136-495-11	FILM	0.068uF	5%	50V
									(AEP, UK, G, EE, CIS)		
C177	1-136-153-00	FILM	0.01uF	5%	50V	C402	1-136-495-11	FILM	0.068uF	5%	50V
C191	1-126-964-11	ELECT	10uF	20%	50V				(AEP, UK, G, EE, CIS)		
			(GRX7/GRX7J/RX77: CND)			C403	1-164-159-21	CERAMIC	0.1uF		50V
C192	1-162-292-31	CERAMIC	680PF	10%	50V				(AEP, UK, G, EE, CIS)		
			(GRX7/GRX7J/RX77: CND)			C404	1-164-159-11	CERAMIC	0.1uF		50V
C193	1-126-964-11	ELECT	10uF	20%	50V				(CND)		
			(GRX7/GRX7J/RX77: CND)			C410	1-126-963-11	ELECT	4.7uF	20%	50V
C194	1-162-286-31	CERAMIC	220PF	10%	50V				(GRX7/GRX7J/RX77: CND)		
			(GRX7/GRX7J/RX77: CND)			C411	1-164-159-11	CERAMIC	0.1uF		50V
C195	1-162-306-11	CERAMIC	0.01uF	20%	16V				(GRX7/GRX7J/RX77: CND)		
			(GRX7/GRX7J/RX77: CND)			C431	1-126-934-11	ELECT	220uF	20%	10V
C196	1-162-306-11	CERAMIC	0.01uF	20%	16V	C432	1-126-933-11	ELECT	100uF	20%	10V
			(GRX7/GRX7J/RX77: CND)			C433	1-126-961-11	ELECT	2.2uF	20%	50V
C301	1-126-160-11	ELECT	1uF	20%	50V	C451	1-136-495-11	FILM	0.068uF	5%	50V
C302	1-130-479-00	MYLAR	0.0047uF	5%	50V				(AEP, UK, G, EE, CIS)		
C303	1-136-165-00	FILM	0.1uF	5%	50V	C452	1-136-495-11	FILM	0.068uF	5%	50V
									(AEP, UK, G, EE, CIS)		
C304	1-136-165-00	FILM	0.1uF	5%	50V	C453	1-164-159-21	CERAMIC	0.1uF		50V
C305	1-126-956-91	ELECT	0.1uF	20%	50V				(AEP, UK, G, EE, CIS)		
			(AEP, UK, G, EE, CIS)			C454	1-164-159-11	CERAMIC	0.1uF		50V
C305	1-126-964-11	ELECT	10uF	20%	50V				(CND)		
			(GRX7/GRX7J/RX77: CND)			C501	1-126-967-11	ELECT	47uF	20%	10V
C306	1-126-160-11	ELECT	1uF	20%	50V	C502	1-164-159-11	CERAMIC	0.1uF		50V
C307	1-126-959-11	ELECT	0.47uF	20%	50V	C503	1-136-173-00	FILM	0.47uF	5%	50V
C308	1-126-964-11	ELECT	10uF	20%	50V	C504	1-126-916-11	ELECT	1000uF	20%	6.3V
C309	1-136-173-00	FILM	0.47uF	5%	50V	C505	1-162-306-11	CERAMIC	0.01uF	20%	16V
C310	1-162-290-31	CERAMIC	470PF	10%	50V	C506	1-136-165-00	FILM	0.1uF	5%	50V
C311	1-126-964-11	ELECT	10uF	20%	50V	C507	1-164-159-11	CERAMIC	0.1uF		50V
C312	1-126-959-11	ELECT	0.47uF	20%	50V	C508	1-126-933-11	ELECT	100uF	20%	10V
C313	1-162-294-31	CERAMIC	0.001uF	10%	50V	C509	1-102-958-00	CERAMIC	20PF	5%	50V
C314	1-126-964-11	ELECT	10uF	20%	50V	C510	1-102-514-11	CERAMIC	22PF	5%	50V
C315	1-126-963-11	ELECT	4.7uF	20%	50V	C571	1-109-889-11	ELECT	1uF	20%	50V
C316	1-126-933-11	ELECT	100uF	20%	10V	C901	1-136-165-00	FILM	0.1uF	5%	50V
C317	1-126-933-11	ELECT	100uF	20%	10V	C902	1-128-548-11	ELECT	4700uF	20%	25V
C320	1-162-290-31	CERAMIC	470PF	10%	50V	C903	1-104-666-11	ELECT	220uF	20%	25V
C331	1-164-159-11	CERAMIC	0.1uF		50V						
C332	1-164-159-11	CERAMIC	0.1uF		50V						
C333	1-162-600-11	CERAMIC	0.0047uF	20%	16V						

Ref. No.	Part No.	Description	Remark	Ref. No.	Part No.	Description	Remark
C904	1-126-967-11	ELECT	47uF 20% 16V	D905	8-719-985-87	DIODE HZS6B1LTA	
C905	1-104-661-91	ELECT	330uF 20% 16V	D906	8-719-911-19	DIODE 1SS119	
C909	1-126-964-11	ELECT	10uF 20% 50V	D907	8-719-024-99	DIODE 11ES2-NTA2B	
C910	1-126-933-11	ELECT	100uF 20% 10V	D908	8-719-024-99	DIODE 11ES2-NTA2B	
C911	1-126-964-11	ELECT	10uF 20% 50V	D909	8-719-024-99	DIODE 11ES2-NTA2B	
C912	1-126-767-11	ELECT	1000uF 20% 16V	D910	8-719-024-99	DIODE 11ES2-NTA2B	
C913	1-126-943-11	ELECT	2200uF 20% 25V	D911	8-719-934-25	DIODE HZS33-1L	
C914	1-126-767-11	ELECT	1000uF 20% 16V	D912	8-719-921-48	DIODE MTZJ-T-72-5.6C	
C915	1-126-967-11	ELECT	47uF 20% 16V	D913	8-719-911-19	DIODE 1SS119	
C916	1-164-159-11	CERAMIC	0.1uF 50V	D914	8-719-024-99	DIODE 11ES2-NTA2B	
C917	1-126-933-11	ELECT	100uF 20% 16V	D915	8-719-986-17	DIODE HZS11B1LTA	
C918	1-126-968-11	ELECT	100uF 20% 50V			< GROUND PLATE >	
C919	1-126-968-11	ELECT	100uF 20% 50V	* EPT1	4-870-539-11	PLATE, GROUND	
C920	1-126-964-11	ELECT	10uF 20% 50V			< IC >	
C921	1-126-947-11	ELECT	47uF 20% 35V	IC101	8-759-495-24	IC M62442FP-TP (GRX7/GRX7J/RX77: CND)	
C951	1-136-165-00	FILM	0.1uF 5% 50V	IC101	8-759-495-86	IC M62442FP-A-TP (AEP, UK, G, EE, CIS)	
C952	1-126-943-11	ELECT	2200uF 20% 25V	IC102	8-759-634-51	IC M5218AP	
C953	1-104-666-11	ELECT	220uF 20% 25V	IC191	8-759-634-50	IC M5218AL (GRX7/GRX7J/RX77: CND)	
C955	1-104-661-91	ELECT	330uF 20% 16V	IC301	8-759-495-26	IC HA12215	
		< CONNECTOR >		IC381	8-749-923-04	IC TOTX178 (CD DIGITAL OUT, OPTICAL)	
CN101	1-778-982-11	CONNECTOR, BOARD TO BOARD 13P		IC501	8-759-496-10	IC uPD780018AYGF-011-3BA	
* CN102	1-568-832-11	SOCKET, CONNECTOR 13P (CND, E2, EA4, TH, MX, AUS)		IC502	8-759-635-63	IC M51943BSL	
CN102	1-568-834-11	SOCKET, CONNECTOR 15P (EXCEPT CND, E2, EA4, TH, MX, AUS)		IC901	8-759-604-86	IC M5F7807L	
* CN103	1-568-946-11	PIN, CONNECTOR 8P		IC902	8-759-231-53	IC TA7805S	
* CN104	1-568-947-11	PIN, CONNECTOR 9P		IC903	8-759-231-58	IC TA7812S	
* CN105	1-568-862-11	SOCKET, CONNECTOR 19P				< JACK >	
CN106	1-568-834-11	SOCKET, CONNECTOR 15P		J101	1-695-188-31	JACK, PIN 4P (MD/VIDEO (AUDIO), IN/OUT)	
* CN107	1-568-836-11	SOCKET, CONNECTOR 17P		J191	1-774-785-11	JACK, PIN 1P (SUPER WOOFER) (GRX7/GRX7J/RX77: CND)	
CN110	1-564-506-11	PLUG, CONNECTOR 3P (GRX7/GRX7J/RX77: CND)				< COIL >	
* CN201	1-568-832-11	SOCKET, CONNECTOR 13P		L301	1-410-524-11	INDUCTOR 220uH	
* CN301	1-568-449-11	HOUSING, CONNECTOR(PC BOARD)3P		L302	1-410-524-11	INDUCTOR 220uH	
		< DIODE >		L381	1-410-521-11	INDUCTOR 100uH	
D141	8-719-911-19	DIODE 1SS119		L392	1-410-521-11	INDUCTOR 100uH	
D401	8-719-911-19	DIODE 1SS119		L401	1-420-872-00	COIL, AIR-CORE (AEP, UK, G, AED, EE, CIS)	
D403	8-719-911-19	DIODE 1SS119 (GRX7/GRX7J/RX77: CND)		L451	1-420-872-00	COIL, AIR-CORE (AEP, UK, G, AED, EE, CIS)	
D404	8-719-911-19	DIODE 1SS119 (GRX7/GRX7J/RX77: CND)		L501	1-410-509-11	INDUCTOR 10uH	
D405	8-719-024-99	DIODE 11ES2-NTA2B (GRX7/GRX7J/RX77: CND)				< TRANSISTOR >	
D406	8-719-024-99	DIODE 11ES2-NTA2B (GRX7/GRX7J/RX77: CND)		Q111	8-729-620-05	TRANSISTOR 2SC2603-EF	
D407	8-719-024-99	DIODE 11ES2-NTA2B (GRX7/GRX7J/RX77: CND)		Q112	8-729-620-05	TRANSISTOR 2SC2603-EF	
D501	8-719-024-99	DIODE 11ES2-NTA2B		Q113	8-729-141-30	TRANSISTOR 2SC3623A-LK	
D502	8-719-024-99	DIODE 11ES2-NTA2B		Q161	8-729-620-05	TRANSISTOR 2SC2603-EF	
D503	8-719-911-19	DIODE 1SS119		Q162	8-729-620-05	TRANSISTOR 2SC2603-EF	
D504	8-719-911-19	DIODE 1SS119		Q163	8-729-141-30	TRANSISTOR 2SC3623A-LK	
D505	8-719-911-19	DIODE 1SS119		Q191	8-729-141-30	TRANSISTOR 2SC3623A-LK (GRX7/GRX7J/RX77: CND)	
D506	8-719-911-19	DIODE 1SS119		Q331	8-729-118-00	TRANSISTOR 2SB1116-L	
D507	8-719-024-99	DIODE 11ES2-NTA2B		Q332	8-729-029-66	TRANSISTOR DTC114ESA	
D508	8-719-911-19	DIODE 1SS119		Q333	8-729-118-00	TRANSISTOR 2SB1116-L	
D901	8-719-024-99	DIODE 11ES2-NTA2B		Q334	8-729-029-66	TRANSISTOR DTC114ESA	
D902	8-719-024-99	DIODE 11ES2-NTA2B		Q335	8-729-029-66	TRANSISTOR DTC114ESA	
D903	8-719-024-99	DIODE 11ES2-NTA2B		Q336	8-729-116-57	TRANSISTOR 2SB1068-K	
D904	8-719-024-99	DIODE 11ES2-NTA2B		Q337	8-729-144-44	TRANSISTOR 2SD1513-K	

MAIN

Ref. No.	Part No.	Description	Remark	Ref. No.	Part No.	Description	Remark
Q338	8-729-029-21	TRANSISTOR DTA114ESA-TP		R141	1-249-433-11	CARBON 22K 5%	1/4W
Q339	8-729-029-66	TRANSISTOR DTC114ESA		R142	1-249-433-11	CARBON 22K 5%	1/4W
Q340	8-729-116-57	TRANSISTOR 2SB1068-K		R143	1-249-417-11	CARBON 1K 5%	1/4W
Q341	8-729-144-44	TRANSISTOR 2SD1513-K					
Q342	8-729-029-21	TRANSISTOR DTA114ESA-TP		R144	1-249-441-11	CARBON 100K 5%	1/4W
				R145	1-247-903-00	CARBON 1M 5%	1/4W
Q343	8-729-029-66	TRANSISTOR DTC114ESA		R151	1-249-417-11	CARBON 1K 5%	1/4W
Q401	8-729-119-76	TRANSISTOR 2SA1175-HFE		R152	1-249-417-11	CARBON 1K 5%	1/4W
		(GRX7/GRX7J/RX77: CND)		R161	1-249-429-11	CARBON 10K 5%	1/4W
Q402	8-729-111-29	TRANSISTOR 2SD1616A-K					
		(GRX7/GRX7J/RX77: CND)		R162	1-247-903-00	CARBON 1M 5%	1/4W
Q431	8-729-140-84	TRANSISTOR 2SC1841-PAFAEA		R163	1-247-903-00	CARBON 1M 5%	1/4W
Q432	8-729-140-82	TRANSISTOR 2SA988-PAFAEA		R164	1-249-419-11	CARBON 1.5K 5%	1/4W
				R165	1-249-433-11	CARBON 22K 5%	1/4W
Q433	8-729-620-05	TRANSISTOR 2SC2603-EF		R166	1-247-887-00	CARBON 220K 5%	1/4W
Q434	8-729-620-05	TRANSISTOR 2SC2603-EF					
Q435	8-729-029-86	TRANSISTOR DTC124ESA		R167	1-249-429-11	CARBON 10K 5%	1/4W
Q436	8-729-119-76	TRANSISTOR 2SA1175-HFE		R168	1-249-437-11	CARBON 47K 5%	1/4W
Q437	8-729-029-86	TRANSISTOR DTC124ESA		R169	1-249-421-11	CARBON 2.2K 5%	1/4W
				R170	1-249-441-11	CARBON 100K 5%	1/4W
Q501	8-729-620-05	TRANSISTOR 2SC2603-EF		R171	1-249-429-11	CARBON 10K 5%	1/4W
Q571	8-729-029-40	TRANSISTOR DTA124ESA					
Q572	8-729-029-40	TRANSISTOR DTA124ESA		R173	1-249-437-11	CARBON 47K 5%	1/4W
Q575	8-729-029-86	TRANSISTOR DTC124ESA		R178	1-249-421-11	CARBON 2.2K 5%	1/4W
Q901	8-729-209-15	TRANSISTOR 2SD2012		R191	1-249-437-11	CARBON 47K 5%	1/4W
						(GRX7/GRX7J/RX77: CND)	
Q902	8-729-620-05	TRANSISTOR 2SC2603-EF		R192	1-249-437-11	CARBON 47K 5%	1/4W
Q903	8-729-029-68	TRANSISTOR DTC114TSA				(GRX7/GRX7J/RX77: CND)	
Q905	8-729-040-20	TRANSISTOR RT1P137L-TP		R193	1-249-437-11	CARBON 47K 5%	1/4W
Q906	8-729-029-40	TRANSISTOR DTA124ESA				(GRX7/GRX7J/RX77: CND)	
Q907	8-729-040-20	TRANSISTOR RT1P137L-TP					
				R194	1-247-843-11	CARBON 3.3K 5%	1/4W
Q908	8-729-029-86	TRANSISTOR DTC124ESA				(GRX7/GRX7J/RX77: CND)	
Q909	8-729-026-68	TRANSISTOR 2SD2525(TP)		R195	1-249-429-11	CARBON 10K 5%	1/4W
Q910	8-729-030-19	TRANSISTOR 2SB1640				(GRX7/GRX7J/RX77: CND)	
Q913	8-729-620-05	TRANSISTOR 2SC2603-EF		R196	1-249-417-11	CARBON 1K 5%	1/4W
Q914	8-729-119-76	TRANSISTOR 2SA1175-HFE				(GRX7/GRX7J/RX77: CND)	
				R197	1-249-441-11	CARBON 100K 5%	1/4W
Q951	8-729-141-83	TRANSISTOR 2SB1094-LK				(GRX7/GRX7J/RX77: CND)	
Q952	8-729-119-76	TRANSISTOR 2SA1175-HFE		R198	1-249-417-11	CARBON 1K 5%	1/4W
						(GRX7/GRX7J/RX77: CND)	
< RESISTOR >							
R101	1-249-417-11	CARBON	1K 5%	1/4W			
R102	1-249-417-11	CARBON	1K 5%	1/4W			
R111	1-249-429-11	CARBON	10K 5%	1/4W			
R112	1-247-903-00	CARBON	1M 5%	1/4W			
R113	1-247-903-00	CARBON	1M 5%	1/4W			
R114	1-249-419-11	CARBON	1.5K 5%	1/4W			
R115	1-249-433-11	CARBON	22K 5%	1/4W			
R116	1-247-887-00	CARBON	220K 5%	1/4W			
R117	1-249-429-11	CARBON	10K 5%	1/4W			
R118	1-249-437-11	CARBON	47K 5%	1/4W			
R119	1-249-421-11	CARBON	2.2K 5%	1/4W			
R120	1-249-441-11	CARBON	100K 5%	1/4W			
R121	1-249-429-11	CARBON	10K 5%	1/4W			
R123	1-249-437-11	CARBON	47K 5%	1/4W			
R124	1-249-421-11	CARBON	2.2K 5%	1/4W			
R125	1-247-843-11	CARBON	3.3K 5%	1/4W			
R126	1-249-437-11	CARBON	47K 5%	1/4W			
R127	1-249-437-11	CARBON	47K 5%	1/4W			
R128	1-249-421-11	CARBON	2.2K 5%	1/4W			
R131	1-247-807-31	CARBON	100 5%	1/4W			
R132	1-247-807-31	CARBON	100 5%	1/4W			
R133	1-247-807-31	CARBON	100 5%	1/4W			
				R199	1-249-429-11	CARBON 10K 5%	1/4W
						(GRX7/GRX7J/RX77: CND)	
				R301	1-249-435-11	CARBON 33K 5%	1/4W
				R302	1-249-421-11	CARBON 2.2K 5%	1/4W
				R303	1-247-807-31	CARBON 100 5%	1/4W
				R304	1-247-807-31	CARBON 100 5%	1/4W
				R305	1-249-421-11	CARBON 2.2K 5%	1/4W
				R306	1-249-428-11	CARBON 8.2K 5%	1/4W
				R307	1-249-428-11	CARBON 8.2K 5%	1/4W
				R308	1-249-425-11	CARBON 4.7K 5%	1/4W
				R309	1-249-433-11	CARBON 22K 5%	1/4W
				R311	1-247-903-00	CARBON 1M 5%	1/4W
				R312	1-247-884-11	CARBON 160K 5%	1/4W
				R313	1-249-441-11	CARBON 100K 5%	1/4W
				R315	1-249-429-11	CARBON 10K 5%	1/4W
				R316	1-249-432-11	CARBON 18K 5%	1/4W
				R317	1-249-429-11	CARBON 10K 5%	1/4W
				R318	1-249-429-11	CARBON 10K 5%	1/4W
				R319	1-247-893-11	CARBON 390K 5%	1/4W
				R321	1-249-422-11	CARBON 2.7K 5%	1/4W
				R322	1-249-428-11	CARBON 8.2K 5%	1/4W
				R324	1-247-876-11	CARBON 75K 5%	1/4W
				R325	1-249-437-11	CARBON 47K 5%	1/4W

Ref. No.	Part No.	Description	Remark	Ref. No.	Part No.	Description	Remark
R326	1-249-437-11	CARBON	47K 5% 1/4W	R440	1-247-903-91	CARBON	1M 5% 1/4W
R327	1-249-437-11	CARBON	47K 5% 1/4W	R441	1-249-429-11	CARBON	10K 5% 1/4W
R328	1-247-876-11	CARBON	75K 5% 1/4W	R443	1-249-417-11	CARBON	1K 5% 1/4W
				R451	1-260-076-11	CARBON	10 5% 1/2W (AEP, UK, G, EE, CIS)
R329	1-249-417-11	CARBON	1K 5% 1/4W				
R330	1-249-425-11	CARBON	4.7K 5% 1/4W	R452	1-260-076-11	CARBON	10 5% 1/2W (AEP, UK, G, EE, CIS)
R331	1-249-425-11	CARBON	4.7K 5% 1/4W	R471	1-260-091-11	CARBON	220 5% 1/2W
R332	1-249-415-11	CARBON	680 5% 1/4W	R472	1-260-091-11	CARBON	220 5% 1/2W
R333	1-249-421-11	CARBON	2.2K 5% 1/4W	R501	1-249-413-11	CARBON	470 5% 1/4W
				R502	1-249-425-11	CARBON	4.7K 5% 1/4W
R334	1-249-415-11	CARBON	680 5% 1/4W	R503	1-249-437-11	CARBON	47K 5% 1/4W
R335	1-249-421-11	CARBON	2.2K 5% 1/4W	R504	1-249-437-11	CARBON	47K 5% 1/4W
R336	1-249-437-11	CARBON	47K 5% 1/4W	R505	1-249-429-11	CARBON	10K 5% 1/4W
R337	1-249-417-11	CARBON	1K 5% 1/4W	R507	1-247-897-11	CARBON	560K 5% 1/4W
R338	1-249-411-11	CARBON	330 5% 1/4W	R508	1-249-425-11	CARBON	4.7K 5% 1/4W
R339	1-249-437-11	CARBON	47K 5% 1/4W	R511	1-247-843-11	CARBON	3.3K 5% 1/4W (AEP, UK, G)
R340	1-249-437-11	CARBON	47K 5% 1/4W	R511	1-249-425-11	CARBON	4.7K 5% 1/4W (GRX7: AUS)
R341	1-249-411-11	CARBON	330 5% 1/4W	R511	1-249-427-11	CARBON	6.8K 5% 1/4W (EE, CIS, E2, MX, JE)
R342	1-249-437-11	CARBON	47K 5% 1/4W	R511	1-249-431-11	CARBON	15K 5% 1/4W (EA4, TH)
R343	1-249-417-11	CARBON	1K 5% 1/4W	R512	1-247-843-11	CARBON	3.3K 5% 1/4W (JE)
R351	1-249-435-11	CARBON	33K 5% 1/4W	R512	1-249-415-11	CARBON	680 5% 1/4W (EA4, TH)
R352	1-249-421-11	CARBON	2.2K 5% 1/4W	R512	1-249-425-11	CARBON	4.7K 5% 1/4W (E2, MX)
R353	1-247-807-31	CARBON	100 5% 1/4W	R512	1-249-427-11	CARBON	6.8K 5% 1/4W (AEP, UK, G, AUS)
R354	1-247-807-31	CARBON	100 5% 1/4W	R512	1-249-435-11	CARBON	33K 5% 1/4W (EE, CIS)
R355	1-249-421-11	CARBON	2.2K 5% 1/4W	R521	1-247-807-31	CARBON	100 5% 1/4W
				R522	1-247-807-31	CARBON	100 5% 1/4W (AEP, UK, G)
R356	1-249-428-11	CARBON	8.2K 5% 1/4W	R523	1-247-807-31	CARBON	100 5% 1/4W (AEP, UK, G)
R357	1-249-428-11	CARBON	8.2K 5% 1/4W	R524	1-249-429-11	CARBON	10K 5% 1/4W
R358	1-249-425-11	CARBON	4.7K 5% 1/4W	R526	1-249-429-11	CARBON	10K 5% 1/4W
R359	1-249-435-11	CARBON	33K 5% 1/4W	R527	1-247-807-31	CARBON	100 5% 1/4W
R391	1-247-807-31	CARBON	100 5% 1/4W	R528	1-247-807-31	CARBON	100 5% 1/4W
				R529	1-247-807-31	CARBON	100 5% 1/4W
R392	1-247-807-31	CARBON	100 5% 1/4W	R530	1-247-807-31	CARBON	100 5% 1/4W
R393	1-249-435-11	CARBON	33K 5% 1/4W	R531	1-247-807-31	CARBON	100 5% 1/4W
R394	1-249-435-11	CARBON	33K 5% 1/4W	R532	1-247-807-31	CARBON	100 5% 1/4W
R401	1-260-076-11	CARBON	10 5% 1/2W (AEP, UK, G, EE, CIS)	R533	1-247-807-31	CARBON	100 5% 1/4W
R402	1-260-076-11	CARBON	10 5% 1/2W (AEP, UK, G, EE, CIS)	R534	1-247-807-31	CARBON	100 5% 1/4W
				R535	1-247-807-31	CARBON	100 5% 1/4W
R406	1-249-437-11	CARBON	47K 5% 1/4W (GRX7/GRX7J/RX77: CND)	R536	1-247-807-31	CARBON	100 5% 1/4W
R407	1-249-437-11	CARBON	47K 5% 1/4W (GRX7/GRX7J/RX77: CND)	R537	1-247-807-31	CARBON	100 5% 1/4W
R408	1-249-425-11	CARBON	4.7K 5% 1/4W (GRX7/GRX7J/RX77: CND)				
R409	1-249-441-11	CARBON	100K 5% 1/4W (GRX7/GRX7J/RX77: CND)	R538	1-247-807-31	CARBON	100 5% 1/4W
R410	1-249-421-11	CARBON	2.2K 5% 1/4W (GRX7/GRX7J/RX77: CND)	R539	1-247-807-31	CARBON	100 5% 1/4W
				R540	1-247-807-31	CARBON	100 5% 1/4W
△R411	1-215-893-11	METAL OXIDE	1.5K 5% 2W F (GRX7/GRX7J)	R541	1-247-807-31	CARBON	100 5% 1/4W
△R411	1-216-456-00	METAL OXIDE	820 5% 2W F (AEP, UK, G, EE, CIS)	R542	1-247-807-31	CARBON	100 5% 1/4W
△R411	1-216-457-00	METAL OXIDE	1.2K 5% 2W F (CND)	R543	1-247-807-31	CARBON	100 5% 1/4W
				R544	1-249-429-11	CARBON	10K 5% 1/4W
R421	1-260-091-11	CARBON	220 5% 1/2W	R545	1-247-807-31	CARBON	100 5% 1/4W
R422	1-260-091-11	CARBON	220 5% 1/2W				
R431	1-249-438-11	CARBON	56K 5% 1/4W				
R432	1-249-437-11	CARBON	47K 5% 1/4W				
R435	1-249-425-11	CARBON	4.7K 5% 1/4W				
R437	1-249-429-11	CARBON	10K 5% 1/4W				
R438	1-249-429-11	CARBON	10K 5% 1/4W				
R439	1-249-425-11	CARBON	4.7K 5% 1/4W				

The components identified by mark \triangle or dotted line with mark \triangle are critical for safety. Replace only with part number specified.	Les composants identifiés par une marque \triangle sont critiques pour la sécurité. Ne les remplacer que par une pièce portant le numéro spécifié.
--	--

MAIN	MOTOR (SLIDE)	MOTOR (TURN)
-------------	----------------------	---------------------

Ref. No.	Part No.	Description			Remark
R546	1-247-843-11	CARBON	3.3K	5%	1/4W
R547	1-247-807-31	CARBON	100	5%	1/4W
R548	1-247-807-31	CARBON	100	5%	1/4W
R549	1-247-807-31	CARBON	100	5%	1/4W
R550	1-247-807-31	CARBON	100	5%	1/4W
R551	1-247-807-31	CARBON	100	5%	1/4W
R552	1-247-807-31	CARBON	100	5%	1/4W
R553	1-249-429-11	CARBON	10K	5%	1/4W
R554	1-247-807-31	CARBON	100	5%	1/4W
R555	1-249-429-11	CARBON	10K	5%	1/4W
R556	1-247-807-31	CARBON	100	5%	1/4W
R557	1-249-429-11	CARBON	10K	5%	1/4W
R558	1-247-807-31	CARBON	100	5%	1/4W
R559	1-249-429-11	CARBON	10K	5%	1/4W
R561	1-247-807-31	CARBON	100	5%	1/4W
R562	1-247-807-31	CARBON	100	5%	1/4W
R563	1-247-807-31	CARBON	100	5%	1/4W
R564	1-247-807-31	CARBON	100	5%	1/4W
R565	1-247-807-31	CARBON	100	5%	1/4W
R566	1-247-807-31	CARBON	100	5%	1/4W
R567	1-247-807-31	CARBON	100	5%	1/4W
R571	1-249-421-11	CARBON	2.2K	5%	1/4W
R572	1-249-441-11	CARBON	100K	5%	1/4W
R576	1-249-429-11	CARBON	10K	5%	1/4W
R577	1-249-417-11	CARBON	1K	5%	1/4W
R901	1-247-843-11	CARBON	3.3K	5%	1/4W
R902	1-249-415-11	CARBON	680	5%	1/4W
R903	1-249-419-11	CARBON	1.5K	5%	1/4W
R904	1-249-414-11	CARBON	560	5%	1/4W
R905	1-249-425-11	CARBON	4.7K	5%	1/4W
R906	1-247-843-11	CARBON	3.3K	5%	1/4W
R907	1-249-415-11	CARBON	680	5%	1/4W
R908	1-249-429-11	CARBON	10K	5%	1/4W
R909	1-249-430-11	CARBON	12K	5%	1/4W
R911	1-249-409-11	CARBON	220	5%	1/4W
R912	1-249-417-11	CARBON	1K	5%	1/4W
R913	1-249-425-11	CARBON	4.7K	5%	1/4W
R914	1-249-409-11	CARBON	220	5%	1/4W
R915	1-249-409-11	CARBON	220	5%	1/4W
R920	1-249-383-11	CARBON	1.5	5%	1/6W
R921	1-249-383-11	CARBON	1.5	5%	1/6W
		< VARIABLE RESISTOR >			
RV301	1-238-600-11	RES, ADJ, CARBON 10K			
RV351	1-238-600-11	RES, ADJ, CARBON 10K			
		< RELAY >			
RY401	1-515-920-11	RELAY (24V)			
		< TERMINAL >			
TM401	1-537-240-31	TERMINAL BOARD (CHECKER PIN) (SPEAKER)			
TM402	1-537-240-31	TERMINAL BOARD (CHECKER PIN) (SURROUND SPEAKER) (CND)			
		< VIBRATOR >			
X501	1-760-489-11	VIBRATOR, CERAMIC (5MHz)			

Ref. No.	Part No.	Description				Remark
X502	1-567-098-41	VIBRATOR, CRYSTAL (32.768kHz)				

*	1-658-578-11	MOTOR (SLIDE) BOARD				

		< CAPACITOR >				
C801	1-162-306-11	CERAMIC	0.01uF	20%	16V	
C804	1-162-306-11	CERAMIC	0.01uF	20%	16V	
C805	1-126-964-11	ELECT	10uF	20%	50V	
		< CONNECTOR >				
* CN801	1-568-947-11	PIN, CONNECTOR 9P				
		< DIODE >				
D801	8-719-010-43	DIODE UZ-5.6BSC				
D804	8-719-911-19	DIODE 1SS119				
D805	8-719-911-19	DIODE 1SS119				
		< IC >				
IC801	8-759-274-09	IC BA6286N				
		< RESISTOR >				
R801	1-249-401-11	CARBON	47	5%	1/4W	
		< SWITCH >				
S801	1-762-527-11	SWITCH, ROTARY				

*	1-658-577-11	MOTOR (TURN) BOARD				

		< CAPACITOR >				
C701	1-162-306-11	CERAMIC	0.01uF	20%	16V	
C702	1-126-964-11	ELECT	10uF	20%	50V	
C705	1-162-306-11	CERAMIC	0.01uF	20%	16V	
		< CONNECTOR >				
CN703	1-750-413-11	CONNECTOR, FFC/FPC 8P				
CN704	1-506-469-11	PIN, CONNECTOR 4P				
		< DIODE >				
D701	8-719-109-69	DIODE RD3.6ES-B2				
		< IC >				
IC701	8-759-633-65	IC M54641L				
		< RESISTOR >				
R706	1-249-411-11	CARBON	330	5%	1/4W	
R707	1-249-401-11	CARBON	47	5%	1/4W	

PANEL

Ref. No.	Part No.	Description	Remark	Ref. No.	Part No.	Description	Remark
*	A-4403-990-A	PANEL BOARD, COMPLETE (EE, CIS)					(EA3)
*	A-4407-013-A	PANEL BOARD, COMPLETE (EXCEPT AEP, UK, G, EE, CIS, EA3)		C766	1-162-305-11	CERAMIC 0.0068uF 30%	16V (EA3)
*	A-4407-015-A	PANEL BOARD, COMPLETE (EA3)		C767	1-162-294-31	CERAMIC 0.001uF 10%	50V (EA3)
*	A-4407-998-A	PANEL BOARD, COMPLETE (AEP, UK,G) *****		C768	1-136-495-11	FILM 0.068uF 5%	50V (EA3)
*	4-949-935-21	CUSHION (FL)		C769	1-126-957-11	ELECT 0.22uF 20%	50V (EA3)
*	4-996-724-01	HOLDER, FL TUBE		C770	1-126-957-11	ELECT 0.22uF 20%	50V (EA3)
		< CAPACITOR >		C771	1-126-967-11	ELECT 47uF 20%	10V (EA3)
C601	1-164-159-11	CERAMIC 0.1uF	50V	C772	1-164-159-11	CERAMIC 0.1uF	50V (EA3)
C602	1-162-306-11	CERAMIC 0.01uF 20%	16V	C773	1-126-967-11	ELECT 47uF 20%	10V (EA3)
C603	1-124-589-11	ELECT 47uF 20%	16V	C774	1-136-495-11	FILM 0.068uF 5%	50V (EA3)
C604	1-126-163-11	ELECT 4.7uF 20%	50V	C775	1-162-305-11	CERAMIC 0.0068uF 30%	16V (EA3)
C605	1-162-294-31	CERAMIC 0.001uF 10%	50V	C776	1-162-294-31	CERAMIC 0.001uF 10%	50V (EA3)
C606	1-126-160-11	ELECT 1uF 20%	50V	C777	1-136-167-00	FILM 0.15uF 5%	50V (EA3)
C607	1-126-160-11	ELECT 1uF 20%	50V	C778	1-126-960-11	ELECT 1uF 20%	50V (EA3)
C608	1-162-294-31	CERAMIC 0.001uF 10%	50V	C779	1-161-494-00	CERAMIC 0.022uF	25V (EA3)
C609	1-162-282-31	CERAMIC 100PF 10%	50V	C780	1-126-961-11	ELECT 2.2uF 20%	50V (EA3)
C610	1-162-282-31	CERAMIC 100PF 10%	50V			< CONNECTOR >	
C611	1-162-282-31	CERAMIC 100PF 10%	50V	* CN601	1-568-856-11	SOCKET, CONNECTOR 13P	
C612	1-162-282-31	CERAMIC 100PF 10%	50V			< DIODE >	
C613	1-162-282-31	CERAMIC 100PF 10%	50V	D602	8-719-986-73	DIODE RB441Q	
C614	1-162-282-31	CERAMIC 100PF 10%	50V	D610	8-719-063-93	LED SLR325VC-N-T32 (ENTER/NEXT)	
C615	1-162-282-31	CERAMIC 100PF 10%	50V	D612	8-719-057-97	LED SEL5923A-TP15 (GROOVE)	
C616	1-162-282-31	CERAMIC 100PF 10%	50V	D613	8-719-063-93	LED SLR325VC-N-T32 (JOG)	
C617	1-162-282-31	CERAMIC 100PF 10%	50V	D614	8-719-064-65	LED SELU5723C-TP15 (DJ MIX)	
C618	1-162-282-31	CERAMIC 100PF 10%	50V	D615	8-719-064-65	LED SELU5723C-TP15 (DJ MIX)	
C619	1-162-282-31	CERAMIC 100PF 10%	50V	D616	8-719-063-93	LED SLR325VC-N-T32 (NON-STOP)	
C620	1-162-282-31	CERAMIC 100PF 10%	50V	D617	8-719-057-97	LED SEL5923A-TP15 (+, ►►)	
C621	1-162-282-31	CERAMIC 100PF 10%	50V	D618	8-719-057-97	LED SEL5923A-TP15 (-, ◄◄)	
C625	1-162-294-31	CERAMIC 0.001uF 10%	50V	D620	8-719-063-93	LED SLR325VC-N-T32 (EFFECT) (GRX7/GRX7J/RX77: CND)	
C626	1-124-589-11	ELECT 47uF 20%	16V	D621	8-719-056-13	LED SML79423C-TP15 (CD, ►►)	
C627	1-162-306-11	CERAMIC 0.01uF 20%	16V	D622	8-719-058-03	LED SEL5423E-TP15 (TAPE B, ►)	
C628	1-162-306-11	CERAMIC 0.01uF 20%	16V	D623	8-719-058-03	LED SEL5423E-TP15 (TAPE B, ◄)	
C629	1-162-306-11	CERAMIC 0.01uF 20%	16V	D624	8-719-058-03	LED SEL5423E-TP15 (TAPE A, ►)	
C630	1-162-306-11	CERAMIC 0.01uF 20%	16V	D625	8-719-058-03	LED SEL5423E-TP15 (TAPE A, ◄)	
C631	1-126-157-11	ELECT 10uF 20%	16V	D651	8-719-063-93	LED SLR325VC-N-T32 (● REC)	
C632	1-126-157-11	ELECT 10uF 20%	16V	D652	8-719-057-97	LED SEL5923A-TP15 (■ PAUSE)	
C633	1-162-303-11	CERAMIC 0.0033uF 30%	16V	D751	8-719-024-99	DIODE 11ES2-NTA2B (EA3)	
C634	1-126-157-11	ELECT 10uF 20%	16V	D752	8-719-024-99	DIODE 11ES2-NTA2B (EA3)	
C635	1-126-163-11	ELECT 4.7uF 20%	50V	D753	8-719-024-99	DIODE 11ES2-NTA2B (EA3)	
C648	1-162-306-11	CERAMIC 0.01uF 20%	16V				
C649	1-124-589-11	ELECT 47uF 20%	16V				
C749	1-164-159-11	CERAMIC 0.1uF	50V				
C752	1-164-159-11	CERAMIC 0.1uF	50V				
C753	1-162-290-31	CERAMIC 470PF 10%	50V				
C754	1-162-306-11	CERAMIC 0.01uF 20%	16V				
C755	1-126-961-11	ELECT 2.2uF 20%	50V				
C756	1-162-294-31	CERAMIC 0.001uF 10%	50V				
C757	1-162-215-31	CERAMIC 47PF 5%	50V				
C758	1-126-964-11	ELECT 10uF 20%	50V				
C759	1-126-956-91	ELECT 0.1uF 20%	50V				
C760	1-162-215-31	CERAMIC 47PF 5%	50V				
C761	1-162-282-31	CERAMIC 100PF 10%	50V				
C762	1-126-961-11	ELECT 2.2uF 20%	50V				
C764	1-126-964-11	ELECT 10uF 20%	50V				
C765	1-126-960-11	ELECT 1uF 20%	50V				

PANEL

Ref. No.	Part No.	Description	Remark	Ref. No.	Part No.	Description	Remark
		<LEAD>		R619	1-249-435-11	CARBON	33K 5% 1/4W
EL2	1-690-880-51	LEAD (WITH CONNECTOR)		R620	1-247-895-00	CARBON	470K 5% 1/4W
		< FERRITE BEAD >		R621	1-249-427-11	CARBON	6.8K 5% 1/4W
FB601	1-410-397-21	FERRITE BEAD INDUCTOR 1.1uH		R622	1-249-409-11	CARBON	220 5% 1/4W
		< FLUORESCENT INDICATOR TUBE >		R623	1-249-410-11	CARBON	270 5% 1/4W
FL601	1-517-731-11	INDICATOR TUBE, FLUORESCENT		R624	1-249-412-11	CARBON	390 5% 1/4W
		< IC >		R625	1-249-413-11	CARBON	470 5% 1/4W
IC601	8-759-536-41	IC TMP87PM74F-6695		R626	1-249-415-11	CARBON	680 5% 1/4W
IC602	8-749-011-05	IC GP1U28X		R627	1-249-416-11	CARBON	820 5% 1/4W
IC603	8-759-495-25	IC BA3833F-E2		R628	1-249-418-11	CARBON	1.2K 5% 1/4W
IC750	8-759-634-51	IC M5218AP		R629	1-249-419-11	CARBON	1.5K 5% 1/4W
IC751	8-759-496-40	IC M65850FP (EA3)		R630	1-249-421-11	CARBON	2.2K 5% 1/4W
		< JACK >		R631	1-247-843-11	CARBON	3.3K 5% 1/4W
J751	1-784-224-11	JACK (LARGE TYPE) (MIX MIC)		R632	1-249-425-11	CARBON	4.7K 5% 1/4W
		< COIL >		R633	1-249-427-11	CARBON	6.8K 5% 1/4W
L601	1-410-509-11	INDUCTOR 10uH		R634	1-249-429-11	CARBON	10K 5% 1/4W
L751	1-410-521-11	INDUCTOR 100uH (EA3)		R636	1-249-427-11	CARBON	6.8K 5% 1/4W
		< TRANSISTOR >		R637	1-249-409-11	CARBON	220 5% 1/4W
Q601	8-729-118-00	TRANSISTOR 2SB1116-L		R638	1-249-410-11	CARBON	270 5% 1/4W
Q602	8-729-118-00	TRANSISTOR 2SB1116-L		R639	1-249-412-11	CARBON	390 5% 1/4W
Q603	8-729-620-05	TRANSISTOR 2SC2603-EF		R640	1-249-413-11	CARBON	470 5% 1/4W
Q604	8-729-029-68	TRANSISTOR DTC114TSA		R641	1-249-415-11	CARBON	680 5% 1/4W
Q607	8-729-029-68	TRANSISTOR DTC114TSA	(GRX7/GRX7J/RX77: CND)	R642	1-249-416-11	CARBON	820 5% 1/4W
Q608	8-729-029-68	TRANSISTOR DTC114TSA		R643	1-249-418-11	CARBON	1.2K 5% 1/4W
Q609	8-729-029-68	TRANSISTOR DTC114TSA		R649	1-249-427-11	CARBON	6.8K 5% 1/4W
Q610	8-729-029-68	TRANSISTOR DTC114TSA		R650	1-249-409-11	CARBON	220 5% 1/4W
Q618	8-729-029-68	TRANSISTOR DTC114TSA		R651	1-249-410-11	CARBON	270 5% 1/4W
Q620	8-729-029-68	TRANSISTOR DTC114TSA		R652	1-249-412-11	CARBON	390 5% 1/4W
Q621	8-729-029-68	TRANSISTOR DTC114TSA		R653	1-249-413-11	CARBON	470 5% 1/4W
		< RESISTOR >		R654	1-249-415-11	CARBON	680 5% 1/4W
R601	1-247-903-00	CARBON	1M 5% 1/4W	R655	1-249-416-11	CARBON	820 5% 1/4W
R602	1-247-807-31	CARBON	100 5% 1/4W	R661	1-249-429-11	CARBON	10K 5% 1/4W
R604	1-249-429-11	CARBON	10K 5% 1/4W	R662	1-249-421-11	CARBON	2.2K 5% 1/4W
R605	1-249-429-11	CARBON	10K 5% 1/4W	R663	1-249-421-11	CARBON	2.2K 5% 1/4W
R606	1-249-429-11	CARBON	10K 5% 1/4W	R664	1-249-409-11	CARBON	220 5% 1/4W
R607	1-249-429-11	CARBON	10K 5% 1/4W	R665	1-249-429-11	CARBON	10K 5% 1/4W
R608	1-247-843-11	CARBON	3.3K 5% 1/4W	R666	1-249-407-11	CARBON	150 5% 1/4W
R609	1-247-843-11	CARBON	3.3K 5% 1/4W	R667	1-247-807-31	CARBON	100 5% 1/4W
R610	1-247-807-31	CARBON	100 5% 1/4W	R668	1-249-407-11	CARBON	150 5% 1/4W
R611	1-247-807-31	CARBON	100 5% 1/4W	R669	1-247-804-11	CARBON	75 5% 1/4W
R612	1-249-401-11	CARBON	47 5% 1/4W	R670	1-249-407-11	CARBON	150 5% 1/4W
R613	1-249-421-11	CARBON	2.2K 5% 1/4W	R671	1-249-407-11	CARBON	150 5% 1/4W
R614	1-249-433-11	CARBON	22K 5% 1/4W	R672	1-249-407-11	CARBON	150 5% 1/4W
R615	1-249-437-11	CARBON	47K 5% 1/4W	R673	1-249-407-11	CARBON	150 5% 1/4W
R616	1-249-441-11	CARBON	100K 5% 1/4W	R674	1-247-804-11	CARBON	75 5% 1/4W
R618	1-249-437-11	CARBON	47K 5% 1/4W	R675	1-247-804-11	CARBON	75 5% 1/4W
				R676	1-247-804-11	CARBON	75 5% 1/4W
				R677	1-247-804-11	CARBON	75 5% 1/4W
				R678	1-247-804-11	CARBON	75 5% 1/4W
				R679	1-247-804-11	CARBON	75 5% 1/4W
				R683	1-249-441-11	CARBON	100K 5% 1/4W
				R684	1-249-441-11	CARBON	100K 5% 1/4W
				R685	1-247-804-11	CARBON	75 5% 1/4W
				R725	1-249-427-11	CARBON	6.8K 5% 1/4W
				R726	1-249-409-11	CARBON	220 5% 1/4W
				R727	1-249-410-11	CARBON	270 5% 1/4W
				R728	1-249-412-11	CARBON	390 5% 1/4W

PANEL

POWER AMP

Ref. No.	Part No.	Description	Remark	Ref. No.	Part No.	Description	Remark
R729	1-249-413-11	CARBON	470 5% 1/4W	S614	1-771-410-11	SWITCH, KEYBOARD (FUNCTION)	
R730	1-249-415-11	CARBON	680 5% 1/4W	S615	1-771-410-11	SWITCH, KEYBOARD (EDIT, DIRECTION)	
R731	1-249-416-11	CARBON	820 5% 1/4W	S616	1-771-410-11	SWITCH, KEYBOARD (PLAY MODE, DOLBY NR)	
R732	1-249-418-11	CARBON	1.2K 5% 1/4W	S617	1-771-410-11	SWITCH, KEYBOARD (REPEAT)	
R733	1-249-419-11	CARBON	1.5K 5% 1/4W	S618	1-771-410-11	SWITCH, KEYBOARD (LOOP)	
R742	1-249-407-11	CARBON	150 5% 1/4W	S619	1-771-410-11	SWITCH, KEYBOARD (FLASH)	
R743	1-247-807-31	CARBON	100 5% 1/4W	S620	1-771-410-11	SWITCH, KEYBOARD (NON-STOP)	
R750	1-249-429-11	CARBON	10K 5% 1/4W	S621	1-771-410-11	SWITCH, KEYBOARD (-, ◀◀)	
R751	1-249-417-11	CARBON	1K 5% 1/4W	S622	1-771-410-11	SWITCH, KEYBOARD (ENTER/NEXT)	
R752	1-249-441-11	CARBON	100K 5% 1/4W	S623	1-771-410-11	SWITCH, KEYBOARD (+, ▶▶)	
R753	1-249-417-11	CARBON	1K 5% 1/4W	S624	1-771-410-11	SWITCH, KEYBOARD (DBFB)	
R754	1-249-433-11	CARBON	22K 5% 1/4W	S625	1-771-410-11	SWITCH, KEYBOARD (GROOVE)	
R755	1-249-429-11	CARBON	10K 5% 1/4W	S631	1-771-410-11	SWITCH, KEYBOARD (TUNER, BAND)	
R756	1-247-885-00	CARBON	180K 5% 1/4W	S632	1-771-410-11	SWITCH, KEYBOARD (CD, ▶▶▶)	
R757	1-247-807-31	CARBON	100 5% 1/4W	S633	1-771-410-11	SWITCH, KEYBOARD (TAPE B, ▶▶)	
R758	1-249-433-11	CARBON	22K 5% 1/4W	S634	1-771-410-11	SWITCH, KEYBOARD (TAPE B, ◀◀)	
R759	1-249-433-11	CARBON	22K 5% 1/4W	S635	1-771-410-11	SWITCH, KEYBOARD (TAPE A, ▶▶)	
R760	1-249-433-11	CARBON	22K 5% 1/4W	S636	1-771-410-11	SWITCH, KEYBOARD (TAPE A, ◀◀)	
R761	1-247-881-00	CARBON	120K 5% 1/4W	S655	1-771-410-11	SWITCH, KEYBOARD (PTY) (AEP, UK, G)	
R762	1-249-433-11	CARBON	22K 5% 1/4W	S656	1-771-410-11	SWITCH, KEYBOARD (● REC)	
R763	1-249-433-11	CARBON	22K 5% 1/4W	S657	1-771-410-11	SWITCH, KEYBOARD (■ PAUSE)	
R764	1-249-433-11	CARBON	22K 5% 1/4W	S658	1-771-410-11	SWITCH, KEYBOARD (HI-DUB)	
R765	1-249-437-11	CARBON	47K 5% 1/4W	S659	1-771-410-11	SWITCH, KEYBOARD (CD SYNC)	
R766	1-249-431-11	CARBON	15K 5% 1/4W			< VIBRATOR >	
R767	1-249-431-11	CARBON	15K 5% 1/4W	X601	1-579-952-21	VIBRATOR, CERAMIC (8MHz)	
		< VARIABLE RESISTOR >					
RV750	1-225-574-11	RES, VAR (MIC LEVEL)					
RV751	1-223-983-11	RES, VAR, CARBON 50K (ECHO LEVEL) (EA3)					
		< SWITCH >					
S601	1-473-534-11	ENCODER, ROTARY (◀◀◀↔▶▶▶, DJ MIX (JOG))					
S602	1-473-392-11	ENCODER, ROTARY (VOLUME)					
S604	1-771-410-11	SWITCH, KEYBOARD (FILE SELECT) (AEP, UK, G, EE, CIS)					
S604	1-771-410-11	SWITCH, KEYBOARD (EFFECT) (GRX7/GRX7J/RX77: CND)					
S605	1-771-410-11	SWITCH, KEYBOARD (SURROUND)					
S606	1-771-410-11	SWITCH, KEYBOARD (KARAOKE PON/MPX)					
S607	1-771-410-11	SWITCH, KEYBOARD (■)					
S608	1-771-410-11	SWITCH, KEYBOARD (TIMER SELECT)					
S609	1-771-410-11	SWITCH, KEYBOARD (CLOCK/TIMER SET)					
S610	1-771-410-11	SWITCH, KEYBOARD (DISPLAY/DEMO)					
S611	1-771-410-11	SWITCH, KEYBOARD (FILE SELECT) (GRX7/GRX7J/RX77: CND)					
S612	1-771-410-11	SWITCH, KEYBOARD (GEO CONTROL) (GRX7/GRX7J/RX77: CND)					
S613	1-771-410-11	SWITCH, KEYBOARD (P FILE MEMORY) (GRX7/GRX7J/RX77: CND)					
		< CAPACITOR >					
C801	1-126-963-11	ELECT	4.7uF 20% 50V				
C801	1-128-582-11	ELECT	10uF 20% 100V				
C802	1-162-286-31	CERAMIC	220PF 10% 50V				
C803	1-162-282-31	CERAMIC	100PF 10% 50V				
C804	1-126-967-11	ELECT	47uF 20% 50V				
C806	1-126-967-11	ELECT	47uF 20% 50V				
C807	1-126-965-11	ELECT	22uF 20% 50V				
C807	1-128-560-11	ELECT	22uF 20% 100V				
C809	1-126-965-11	ELECT	22uF 20% 50V				
C809	1-128-560-11	ELECT	22uF 20% 100V				
C810	1-164-159-11	CERAMIC	0.1uF 50V				
C811	1-136-495-11	FILM	0.068uF 5% 50V				
C812	1-136-495-11	FILM	0.068uF 5% 50V				
C813	1-162-306-11	CERAMIC	0.01uF 20% 16V				
C814	1-162-306-11	CERAMIC	0.01uF 20% 16V				
							(AEP, UK, G, EE, CIS)

POWER AMP

Ref. No.	Part No.	Description	Remark	Ref. No.	Part No.	Description	Remark
C841	1-130-777-00	FILM	0.1uF 10% 100V (GRX7/GRX7J/RX77: CND)	Q832	8-729-140-84	TRANSISTOR 2SC1841-PAFAEA (GRX7/GRX7J/RX77: CND)	
C841	1-136-165-00	FILM	0.1uF 5% 50V (AEP, UK, G, EE, CIS)	Q851	8-729-140-84	TRANSISTOR 2SC1841-PAFAEA	
C842	1-117-750-11	ELECT	3300uF 20% 63V (CND)	< RESISTOR >			
C842	1-126-974-11	ELECT	3300uF 20% 50V (AEP, UK, G, EE, CIS)	R801	1-249-417-11	CARBON 1K 5% 1/4W	
C842	1-128-493-11	ELECT	4700uF 20% 71V (GRX7/GRX7J)	R802	1-249-437-11	CARBON 47K 5% 1/4W	
C843	1-126-925-11	ELECT	470uF 20% 10V (AEP, UK, G, EE, CIS)	R803	1-247-826-00	CARBON 620 5% 1/4W (AEP, UK, G, EE, CIS)	
C843	1-126-934-11	ELECT	220uF 20% 10V (GRX7/GRX7J/RX77: CND)	R803	1-249-412-11	CARBON 390 5% 1/4W (GRX7/GRX7J/RX77: CND)	
C851	1-126-963-11	ELECT	4.7uF 20% 50V (EXCEPT CND)	R804	1-249-437-11	CARBON 47K 5% 1/4W	
C851	1-128-582-11	ELECT	10uF 20% 100V (CND)	R805	1-260-105-11	CARBON 3.3K 5% 1/2W (AEP, UK, G, EE, CIS)	
C852	1-162-286-31	CERAMIC	220PF 10% 50V	R805	1-260-107-11	CARBON 4.7K 5% 1/2W (GRX7/GRX7J/RX77: CND)	
C853	1-162-282-31	CERAMIC	100PF 10% 50V	R806	1-260-105-11	CARBON 3.3K 5% 1/2W (AEP, UK, G, EE, CIS)	
C854	1-126-967-11	ELECT	47uF 20% 50V	R806	1-260-107-11	CARBON 4.7K 5% 1/2W (GRX7/GRX7J/RX77: CND)	
C856	1-126-967-11	ELECT	47uF 20% 50V	△R807	1-212-881-11	FUSIBLE 100 5% 1/4W F	
C857	1-126-965-11	ELECT	22uF 20% 50V (AEP, UK, G, EE, CIS)	△R808	1-220-755-11	METAL 0.22 10% 2W F (AEP, UK, G, EE, CIS)	
C857	1-128-560-11	ELECT	22uF 20% 100V (GRX7/GRX7J/RX77: CND)	△R808	1-220-893-11	METAL 0.22 10% 5W F (GRX7/GRX7J/RX77: CND)	
C861	1-136-495-11	FILM	0.068uF 5% 50V	R809	1-260-076-11	CARBON 10 5% 1/2W	
C862	1-136-495-11	FILM	0.068uF 5% 50V	R811	1-249-417-11	CARBON 1K 5% 1/4W	
C891	1-130-777-00	FILM	0.1uF 10% 100V (GRX7/GRX7J/RX77: CND)	R812	1-249-431-11	CARBON 15K 5% 1/4W	
C891	1-136-165-00	FILM	0.1uF 5% 50V (AEP, UK, G, EE, CIS)	R813	1-249-441-11	CARBON 100K 5% 1/4W	
C892	1-117-750-11	ELECT	3300uF 20% 63V (CND)	R814	1-260-099-11	CARBON 1K 5% 1/2W (AEP, UK, G, EE, CIS)	
C892	1-126-974-11	ELECT	3300uF 20% 50V (AEP, UK, G, EE, CIS)	R814	1-260-103-11	CARBON 2.2K 5% 1/2W (CND)	
C892	1-128-493-11	ELECT	4700uF 20% 71V (GRX7/GRX7J)	R814	1-260-105-11	CARBON 3.3K 5% 1/2W (GRX7/GRX7J)	
< CONNECTOR >				R816	1-260-099-11	CARBON 1K 5% 1/2W (AEP, UK, G, EE, CIS)	
CN801	1-778-981-11	CONNECTOR, BOARD TO BOARD 13P		R816	1-260-103-11	CARBON 2.2K 5% 1/2W (CND)	
< DIODE >				R816	1-260-105-11	CARBON 3.3K 5% 1/2W (GRX7/GRX7J)	
D800	8-719-302-38	DIODE RBV-602-01 (GRX7/GRX7J)		△R820	1-202-972-61	FUSIBLE 1 5% 1/4W F	
D800	8-719-510-68	DIODE D5SBA20F01 (R700/RX77/RX77S)		R831	1-249-441-11	CARBON 100K 5% 1/4W (GRX7/GRX7J/RX77: CND)	
D801	8-719-911-19	DIODE 1SS119		R832	1-249-441-11	CARBON 100K 5% 1/4W (GRX7/GRX7J/RX77: CND)	
D841	8-719-911-19	DIODE 1SS119		R833	1-247-881-00	CARBON 120K 5% 1/4W (GRX7/GRX7J)	
D842	8-719-911-19	DIODE 1SS119		R833	1-249-441-11	CARBON 100K 5% 1/4W (CND)	
D843	8-719-911-19	DIODE 1SS119		R841	1-249-421-11	CARBON 2.2K 5% 1/4W (AEP, UK, G, EE, CIS)	
D851	8-719-911-19	DIODE 1SS119		R841	1-249-428-11	CARBON 8.2K 5% 1/4W (GRX7/GRX7J/RX77: CND)	
< IC >				R842	1-249-425-11	CARBON 4.7K 5% 1/4W (AEP, UK, G, EE, CIS)	
IC801	8-749-900-34	IC STK-4182MK2 (AEP, UK, G, EE, CIS)		R842	1-249-429-11	CARBON 10K 5% 1/4W (GRX7/GRX7J/RX77: CND)	
IC801	8-749-921-04	IC STK-4211MK2 (CND)		R843	1-247-882-11	CARBON 130K 5% 1/4W (AEP, UK, G, EE, CIS)	
IC801	8-749-921-68	IC STK-4231MK2 (GRX7/GRX7J)		R843	1-247-895-00	CARBON 470K 5% 1/4W (GRX7/GRX7J/RX77: CND)	
< TRANSISTOR >							
Q801	8-729-140-84	TRANSISTOR 2SC1841-PAFAEA					
Q831	8-729-029-86	TRANSISTOR DTC124ESA (GRX7/GRX7J/RX77: CND)					

The components identified by mark △ or dotted line with mark △ are critical for safety. Replace only with part number specified.

Les composants identifiés par une marque △ sont critiques pour la sécurité. Ne les remplacer que par une pièce portant le numéro spécifié.

POWER AMP

SENSOR

TCB

Ref. No.	Part No.	Description	Remark			Ref. No.	Part No.	Description	Remark			
R844	1-249-421-11	CARBON	2.2K	5%	1/4W	C16	1-163-038-91	CERAMIC CHIP	0.1uF	25V		
					(AEP, UK, G, EE, CIS)	C19	1-163-249-11	CERAMIC CHIP	82PF	5%	50V	
R844	1-249-425-11	CARBON	4.7K	5%	1/4W	C21	1-163-141-00	CERAMIC CHIP	0.001uF	5%	50V	
					(CND)	C22	1-163-031-11	CERAMIC CHIP	0.01uF	50V		
R844	1-249-428-11	CARBON	8.2K	5%	1/4W	C23	1-163-235-11	CERAMIC CHIP	22PF	5%	50V	
					(GRX7/GRX7J)	C24	1-163-239-11	CERAMIC CHIP	33PF	5%	50V	
R851	1-249-417-11	CARBON	1K	5%	1/4W	C26	1-126-967-11	ELECT	47uF	20%	16V	
R852	1-249-437-11	CARBON	47K	5%	1/4W	C28	1-126-967-11	ELECT	47uF	20%	16V	
R853	1-247-826-00	CARBON	620	5%	1/4W	C29	1-162-306-11	CERAMIC	0.01uF	30%	16V	
					(AEP, UK, G, EE, CIS)	C30	1-126-961-11	ELECT	2.2uF	20%	50V	
R853	1-249-412-11	CARBON	390	5%	1/4W	C31	1-163-031-11	CERAMIC CHIP	0.01uF	50V		
					(GRX7/GRX7J/RX77: CND)	C32	1-163-038-91	CERAMIC CHIP	0.1uF	25V		
R854	1-249-437-11	CARBON	47K	5%	1/4W	C33	1-163-038-91	CERAMIC CHIP	0.1uF	25V		
R855	1-260-105-11	CARBON	3.3K	5%	1/2W	C34	1-163-229-11	CERAMIC CHIP	12PF	5%	50V	
					(AEP, UK, G, EE, CIS)	C35	1-163-038-91	CERAMIC CHIP	0.1uF	25V		
R855	1-260-107-11	CARBON	4.7K	5%	1/2W	C36	1-163-141-00	CERAMIC CHIP	0.001uF	5%	50V	
					(GRX7/GRX7J/RX77: CND)	C37	1-163-141-00	CERAMIC CHIP	0.001uF	5%	50V	
R856	1-260-105-11	CARBON	3.3K	5%	1/2W	C39	1-163-141-00	CERAMIC CHIP	0.001uF	5%	50V	
					(AEP, UK, G, EE, CIS)	C40	1-126-967-11	ELECT	47uF	20%	16V	
R856	1-260-107-11	CARBON	4.7K	5%	1/2W	C41	1-163-031-11	CERAMIC CHIP	0.01uF	50V		
					(GRX7/GRX7J/RX77: CND)	C42	1-163-038-91	CERAMIC CHIP	0.1uF	25V		
△ R857	1-212-881-11	FUSIBLE	100	5%	1/4W	F	C43	1-163-031-91	CERAMIC CHIP	0.01uF	50V	
△ R858	1-220-755-11	METAL	0.22	10%	2W	F	C44	1-163-038-91	CERAMIC CHIP	0.1uF	25V	
					(AEP, UK, G, EE, CIS)	C45	1-163-077-00	CERAMIC CHIP	0.1uF	50V		
△ R858	1-220-893-11	METAL	0.22	10%	5W	F	C46	1-126-967-11	ELECT	47uF	20%	16V
					(GRX7/GRX7J/RX77: CND)	C47	1-126-301-11	ELECT	1.0uF	20%	50V	
R859	1-260-076-11	CARBON	10	5%	1/2W	C48	1-163-059-00	CERAMIC CHIP	0.01uF	50V		
R861	1-249-417-11	CARBON	1K	5%	1/4W	C49	1-126-964-11	ELECT	10uF	20%	50V	
R862	1-249-431-11	CARBON	15K	5%	1/4W	C50	1-126-960-11	ELECT	1.0uF	20%	50V	
R863	1-249-441-11	CARBON	100K	5%	1/4W	C51	1-126-959-11	ELECT	0.47uF	20%	50V	
						C52	1-126-960-11	ELECT	1.0uF	20%	50V	
< THERMISTOR >						C53	1-126-964-11	ELECT	10uF	20%	50V	
TH831	1-807-796-11	THERMISTOR (GRX7/GRX7J/RX77: CND)				C54	1-104-396-11	ELECT	10uF	20%	16V	
*****						C55	1-104-396-11	ELECT	10uF	20%	16V	
*	1-658-576-11	SENSOR BOARD				C56	1-104-396-11	ELECT	10uF	20%	16V	
*****						C57	1-163-017-00	CERAMIC CHIP	0.0047uF	10%	50V	
< IC >						C58	1-163-017-00	CERAMIC CHIP	0.0047uF	10%	50V	
IC702	8-749-924-18	IC PHOTO INTERRUPTER RPI-1391				C59	1-163-989-11	CERAMIC CHIP	33000PF	10%	25V	
IC703	8-749-924-30	IC PHOTO REFLECTOR GP2S28				C60	1-163-989-11	CERAMIC CHIP	33000PF	10%	25V	
< RESISTOR >						C61	1-126-301-11	ELECT	1.0uF	20%	50V	
R701	1-249-416-11	CARBON	820	5%	1/4W	C62	1-163-031-11	CERAMIC CHIP	0.01uF	50V		
R702	1-249-407-11	CARBON	150	5%	1/4W	C63	1-163-139-00	CERAMIC CHIP	820PF	5%	50V	
*****						C65	1-126-967-11	ELECT	47uF	20%	16V	
*	A-4303-588-A	TCB BOARD, COMPLETE (EE,CIS)				C66	1-163-031-11	CERAMIC CHIP	0.01uF	50V		
*****						C67	1-126-162-11	ELECT	3.3uF	20%	50V	
< CAPACITOR >						C68	1-163-031-11	CERAMIC	0.01uF	50V		
C1	1-163-141-00	CERAMIC CHIP	0.001uF	5%	50V	C69	1-126-967-11	ELECT	47uF	20%	16V	
C2	1-126-967-11	ELECT	47uF	20%	16V	C71	1-162-306-11	CERAMIC	0.01uF	30%	16V	
C3	1-163-038-91	CERAMIC CHIP	0.1uF	25V		C72	1-126-967-11	ELECT	47uF	20%	16V	
C5	1-163-031-11	CERAMIC CHIP	0.01uF	50V		C73	1-163-031-11	CERAMIC CHIP	0.01uF	50V		
C6	1-163-038-91	CERAMIC CHIP	0.1uF	25V		C74	1-163-031-11	CERAMIC CHIP	0.01uF	50V		
C7	1-101-004-00	CERAMIC	0.01uF	50V		C1701	1-162-294-31	CERAMIC CHIP	1000PF	10%	50V	
C8	1-163-031-11	CERAMIC CHIP	0.01uF	50V		C1702	1-130-014-00	FILM	470PF	5%	50V	
C9	1-163-031-11	CERAMIC CHIP	0.01uF	50V		C1703	1-126-959-11	ELECT	0.47uF	20%	50V	
C10	1-162-306-11	CERAMIC CHIP	0.01uF	30%	16V	C1704	1-126-959-11	ELECT	0.47uF	20%	50V	
						C1705	1-163-035-00	CERAMIC CHIP	0.047uF	50V		
						C1706	1-126-960-11	ELECT	1.0uF	20%	50V	

<p>The components identified by mark △ or dotted line with △ are critical for safety. Replace only with part number specified.</p>	<p>Les composants identifiés par une marque △ sont critiques pour la sécurité. Ne les remplacer que par une pièce portant le numéro spécifié.</p>
--	---

TCB

Ref. No.	Part No.	Description				Remark	Ref. No.	Part No.	Description				Remark
C1707	1-163-129-00	CERAMIC CHIP	330PF	5%	50V	JR46	1-216-296-91	METAL CHIP	0	5%	1/8W		
C1710	1-163-141-00	CERAMIC CHIP	0.001uF	5%	50V	JR47	1-216-295-91	METAL CHIP	0	5%	1/10W		
C1711	1-163-141-00	CERAMIC CHIP	0.001uF	5%	50V	JR48	1-216-295-91	METAL CHIP	0	5%	1/10W		
C1712	1-130-736-11	FILM	0.01uF	5%	50V	JR49	1-216-296-91	METAL CHIP	0	5%	1/8W		
C1713	1-130-736-11	FILM	0.01uF	5%	50V	JR51	1-216-295-91	METAL CHIP	0	5%	1/10W		
C1714	1-126-960-11	ELECT	1.0uF	20%	50V	JR52	1-216-295-91	METAL CHIP	0	5%	1/10W		
C1715	1-126-960-11	ELECT	1.0uF	20%	50V	JR53	1-216-296-91	METAL CHIP	0	5%	1/8W		
C1716	1-126-960-11	ELECT	1.0uF	20%	50V	JR54	1-216-295-91	METAL CHIP	0	5%	1/10W		
C1719	1-126-967-11	ELECT	47uF	20%	16V	JR1701	1-216-295-91	METAL CHIP	0	5%	1/10W		
C1720	1-163-031-11	CERAMIC CHIP	0.01uF		50V	JR1702	1-216-295-91	METAL CHIP	0	5%	1/10W		
C1723	1-163-031-11	CERAMIC CHIP	0.01uF		50V	JR1703	1-216-295-91	METAL CHIP	0	5%	1/10W		
C1724	1-163-031-11	CERAMIC CHIP	0.01uF		50V	JR1704	1-216-295-91	METAL CHIP	0	5%	1/10W		
C1725	1-126-967-11	ELECT	47uF	20%	16V	JR1705	1-216-295-91	METAL CHIP	0	5%	1/10W		
C1726	1-126-960-11	ELECT	1.0uF	20%	50V			< COIL >					
C1727	1-126-960-11	ELECT	1.0uF	20%	50V	L3	1-410-521-11	MICRO INDUCTOR			100uH		
C1728	1-126-966-11	ELECT	33uF	20%	16V	L41	1-407-500-00	MICRO INDUCTOR			4.7mH		
		< CERAMIC FILTER >				L1701	1-409-497-11	COIL (FILTER)					
CF1	1-567-389-11	FILTER, CERAMIC						< LOW-PASS FILTER >					
CF3	1-567-389-11	FILTER, CERAMIC											
		< CONNECTOR >				LPF41	1-239-845-11	FILTER, LOW PASS					
* CN1	1-568-834-11	SOCKET, CONNECTOR 15P				LPF42	1-239-845-11	FILTER, LOW PASS					
		< TRIMMER >						< TRANSISTOR >					
CT1701	1-141-444-11	CAP, CERAMIC TRIMMER 50PF				Q1	8-729-201-27	TRANSISTOR	2SC2715Y				
CT1701	1-141-569-11	CAP, ADJ 50PF				Q2	8-729-201-27	TRANSISTOR	2SC2715Y				
		< DIODE >				Q3	8-729-201-27	TRANSISTOR	2SC2715Y				
D21	8-719-976-99	DIODE DTZ5.1B				Q4	8-729-201-27	TRANSISTOR	2SC2715Y				
D41	8-719-016-74	DIODE 1SS352				Q5	8-729-216-22	TRANSISTOR	MUN2111				
D42	8-719-016-74	DIODE 1SS352				Q9	8-729-216-22	TRANSISTOR	2SA812-M5M6				
D43	8-719-016-74	DIODE 1SS352				Q11	8-729-421-22	TRANSISTOR	MUN2211				
D1701	8-719-016-74	DIODE 1SS352				Q12	8-729-421-22	TRANSISTOR	MUN2211				
D1702	8-719-016-74	DIODE 1SS352				Q13	8-729-421-22	TRANSISTOR	MUN2211				
D1703	8-719-991-33	DIODE 1SS133T				Q14	8-729-421-22	TRANSISTOR	MUN2211				
D1704	8-719-016-74	DIODE 1SS352				Q1701	8-729-424-08	TRANSISTOR	MUN2111				
		< FRONT-END >				Q1702	8-729-027-43	TRANSISTOR	RT1N141C				
FE1	1-693-335-11	FRONT END (3 GANG)				Q1703	8-729-421-22	TRANSISTOR	MUN2211				
FE2	1-233-514-11	ENCAPSULATED COMPONENT						< RESISTOR >					
		< IC >				R1	1-249-401-11	CARBON	47	5%	1/4W		
IC21	8-759-288-54	IC LC72130				R2	1-216-037-00	METAL CHIP	330	5%	1/10W		
IC41	8-759-495-82	IC LA1838				R3	1-216-037-00	METAL CHIP	330	5%	1/10W		
IC1701	8-759-063-04	IC IR3R42				R5	1-216-037-00	METAL CHIP	330	5%	1/10W		
IC1702	8-759-140-53	IC uPD4053BC				R6	1-216-081-00	METAL CHIP	22K	5%	1/10W		
		< IFT >				R7	1-216-037-00	METAL CHIP	330	5%	1/10W		
IFT41	1-409-636-11	TRANSFORMER, IF (CERAMIC FILTER)				R8	1-216-037-00	METAL CHIP	330	5%	1/10W		
		< JUMPER RESISTOR >				R9	1-216-081-00	METAL CHIP	22K	5%	1/10W		
JR2	1-216-295-91	METAL CHIP	0	5%	1/10W	R10	1-216-037-00	METAL CHIP	330	5%	1/10W		
JR6	1-216-295-91	METAL CHIP	0	5%	1/10W	R11	1-216-081-00	METAL CHIP	22K	5%	1/10W		
JR8	1-216-295-91	METAL CHIP	0	5%	1/10W	R12	1-216-037-00	METAL CHIP	330	5%	1/10W		
JR9	1-216-295-91	METAL CHIP	0	5%	1/10W	R13	1-216-037-00	METAL CHIP	330	5%	1/10W		
JR12	1-216-296-91	METAL CHIP	0	5%	1/8W	R14	1-216-081-00	METAL CHIP	22K	5%	1/10W		
						R18	1-216-073-00	METAL CHIP	10K	5%	1/10W		
						R19	1-216-073-00	METAL CHIP	10K	5%	1/10W		
						R21	1-249-417-11	CARBON	1.0K	5%	1/4W		
						R22	1-249-417-11	CARBON	1.0K	5%	1/4W		
						R23	1-249-417-11	CARBON	1.0K	5%	1/4W		
						R24	1-247-807-31	CARBON	100	5%	1/4W		

Ref. No.	Part No.	Description	Remark	Ref. No.	Part No.	Description	Remark
C50	1-126-960-11	ELECT	1.0uF 20%			< IC >	
C51	1-126-959-11	ELECT	0.47uF 20%				
C52	1-126-960-11	ELECT	1.0uF 20%				
C53	1-126-964-11	ELECT	10uF 20%				
C54	1-104-396-11	ELECT	10uF 20%				
C55	1-104-396-11	ELECT	10uF 20%				
C56	1-104-396-11	ELECT	10uF 20%			< IFT >	
C57	1-163-017-00	CERAMIC CHIP	0.0047uF 10%				
C58	1-163-017-00	CERAMIC CHIP	0.0047uF 10%				
C59	1-163-809-11	CERAMIC CHIP	0.047uF 10%			< JUMPER RESISTOR >	
C60	1-163-809-11	CERAMIC CHIP	0.047uF 10%				
C61	1-126-301-11	ELECT	1uF 20%				
C62	1-163-031-11	CERAMIC CHIP	0.01uF 50V				
C63	1-163-129-00	CERAMIC CHIP	330PF 5%				
C65	1-126-967-11	ELECT	47uF 20%				
C66	1-163-031-11	CERAMIC CHIP	0.01uF 50V				
C67	1-126-16211	ELECT	3.3uF 20%				
C68	1-163-031-11	CERAMIC	0.01uF 50V				
C69	1-126-967-11	ELECT	47uF 20%				
C71	1-162-306-11	CERAMIC	0.01uF 30%				
C72	1-126-967-11	ELECT	47uF 20%				
C73	1-163-031-11	CERAMIC	0.01uF 50V				
C74	1-163-031-11	CERAMIC	0.01uF 50V				
C120	1-163-105-00	CERAMIC CHIP	33PF 5%				
C1751	1-164-159-21	CERAMIC	0.1uF 50V			< COIL >	
C1752	1-126-967-11	ELECT	47uF 20%				
C1753	1-126-964-11	ELECT	10uF 20%				
C1754	1-162-291-31	CERAMIC	560PF 10%				
C1755	1-126-964-11	ELECT	10uF 20%				
C1756	1-126-961-11	ELECT	2.2uF 20%				
C1757	1-162-288-31	CERAMIC	330PF 10%				
C1758	1-163-031-11	CERAMIC CHIP	0.01uF 50V			< LOW-PASS FILTER >	
C1759	1-163-135-00	CERAMIC CHIP	560PF 5%				
C1760	1-163-031-11	CERAMIC CHIP	0.01uF 50V				
C1761	1-163-245-11	CERAMIC CHIP	56PF 5%			< TRANSISTOR >	
C1762	1-163-245-11	CERAMIC CHIP	56PF 5%				
C1763	1-126-961-11	ELECT	2.2uF 20%				
< CERAMIC FILTER >							
CF1	1-579-374-71	FILTER, CERAMIC					
CF2	1-760-393-11	FILTER, CERAMIC					
CF3	1-760-393-11	FILTER, CERAMIC					
< CONNECTOR >							
* CN1	1-568-834-11	SOCKET, CONNECTOR 15P					
< DIODE >							
D21	8-719-976-99	DIODE UDZ-TE-17-5.1B					
D41	8-719-016-74	DIODE 1SS352-TPH3					
D42	8-719-991-33	DIODE 1SS133T-77					
D1751	8-719-016-74	DIODE 1SS352-TPH3					
< FRONT-END >							
FE1	1-693-357-11	FRONT END (4 GANG)					
FE2	1-233-514-11	ENCAPSULATED COMPONENT					
IC21	8-759-288-54	IC LC72130					
IC41	8-759-495-82	IC LA1838					
IC1751	8-759-634-51	IC M5218AP					
IC1752	8-759-450-86	IC BU1922					
< IFT >							
IFT41	1-409-636-11	TRANSFORMER, IF (CERAMIC FILTER)					
< JUMPER RESISTOR >							
JR2	1-216-295-91	METAL CHIP	0 5%				1/10W
JR6	1-216-295-91	METAL CHIP	0 5%				1/10W
JR8	1-216-295-91	METAL CHIP	0 5%				1/10W
JR9	1-216-295-91	METAL CHIP	0 5%				1/10W
JR12	1-216-296-91	METAL CHIP	0 5%				1/8W
JR46	1-216-296-91	METAL CHIP	0 5%				1/8W
JR47	1-216-295-11	METAL CHIP	0 5%				1/10W
JR48	1-216-295-11	METAL CHIP	0 5%				1/10W
JR49	1-216-296-11	METAL CHIP	0 5%				1/8W
JR51	1-216-295-11	METAL CHIP	0 5%				1/10W
JR52	1-216-295-11	METAL CHIP	0 5%				1/10W
JR53	1-216-296-11	METAL CHIP	0 5%				1/8W
JR54	1-216-295-11	METAL CHIP	0 5%				1/10W
< COIL >							
L2	1-414-142-11	MICRO INDUCTOR					1uH
L3	1-410-521-11	MICRO INDUCTOR					100uH
L4	1-410-515-11	INDUCTOR					33uH
L41	1-407-500-00	MICRO INDUCTOR					4.7mH
L1751	1-410-521-11	MICRO INDUCTOR					100uH
< LOW-PASS FILTER >							
LPF41	1-239-845-11	FILTER, LOW PASS					
LPF42	1-239-845-11	FILTER, LOW PASS					
< TRANSISTOR >							
Q1	8-729-201-27	TRANSISTOR 2SC2715Y-TE85L					
Q2	8-729-201-27	TRANSISTOR 2SC2715Y-TE85L					
Q3	8-729-201-27	TRANSISTOR 2SC2715Y-TE85L					
Q4	8-729-201-27	TRANSISTOR 2SC2715Y-TE85L					
Q5	8-729-424-08	TRANSISTOR MUN2111					
Q9	8-729-216-22	TRANSISTOR 2SA812-M5M6					
Q11	8-729-421-22	TRANSISTOR MUN2211					
Q12	8-729-421-22	TRANSISTOR MUN2211					
Q13	8-729-421-22	TRANSISTOR MUN2211					
Q14	8-729-421-22	TRANSISTOR MUN2211					
< RESISTOR >							
R1	1-249-401-11	CARBON	47 5%				1/4W
R2	1-216-037-00	METAL CHIP	330 5%				1/10W
R3	1-216-037-00	METAL CHIP	330 5%				1/10W
R5	1-216-037-00	METAL CHIP	330 5%				1/10W
R6	1-216-081-00	METAL CHIP	22K 5%				1/10W
R7	1-216-037-00	METAL CHIP	330 5%				1/10W
R8	1-216-037-00	METAL CHIP	330 5%				1/10W
R9	1-216-081-00	METAL CHIP	22K 5%				1/10W
R10	1-216-037-00	METAL CHIP	330 5%				1/10W
R11	1-216-081-00	METAL CHIP	22K 5%				1/10W

TCB

TRANSFORMER

Ref. No.	Part No.	Description	Remark
R12	1-216-037-00	METAL CHIP	330 5% 1/10W
R13	1-216-037-00	METAL CHIP	330 5% 1/10W
R14	1-216-081-00	METAL CHIP	22K 5% 1/10W
R18	1-216-073-00	METAL CHIP	10K 5% 1/10W
R19	1-216-073-00	METAL CHIP	10K 5% 1/10W
R21	1-216-049-91	METAL CHIP	1.0K 5% 1/10W
R22	1-216-049-91	METAL CHIP	1.0K 5% 1/10W
R23	1-216-049-91	METAL CHIP	1.0K 5% 1/10W
R24	1-216-025-91	METAL CHIP	100 5% 1/10W
R25	1-249-417-11	CARBON	1K 5% 1/4W
R26	1-249-437-11	CARBON	47K 5% 1/4W
R27	1-249-429-11	CARBON	10K 5% 1/4W
R28	1-249-417-11	CARBON	1K 5% 1/4W
R29	1-216-061-00	METAL CHIP	3.3K 5% 1/10W
R30	1-216-186-00	METAL CHIP	330 5% 1/8W
R31	1-216-025-91	METAL CHIP	100 5% 1/10W
R32	1-249-425-11	CARBON	4.7K 5% 1/4W
R33	1-249-425-11	CARBON	4.7K 5% 1/4W
R34	1-249-425-11	CARBON	4.7K 5% 1/10W
R35	1-216-214-00	METAL CHIP	4.7K 5% 1/8W
R36	1-216-025-91	METAL CHIP	100 5% 1/10W
R37	1-216-073-00	METAL CHIP	10K 5% 1/10W
R38	1-216-089-91	METAL CHIP	47K 5% 1/10W
R39	1-249-429-11	CARBON	10K 5% 1/4W
R41	1-216-013-00	METAL CHIP	33 5% 1/10W
R42	1-216-065-00	METAL CHIP	4.7K 5% 1/10W
R43	1-216-037-00	METAL CHIP	330 5% 1/10W
R44	1-216-001-00	METAL CHIP	10 5% 1/10W
R45	1-247-843-11	CARBON	3.3K 5% 1/4W
R46	1-216-065-00	METAL CHIP	4.7K 5% 1/10W
R47	1-216-097-91	METAL CHIP	100K 5% 1/10W
R48	1-249-417-11	CARBON	1K 5% 1/4W
R49	1-216-049-91	METAL CHIP	1.0K 5% 1/10W
R50	1-216-065-00	METAL CHIP	4.7K 5% 1/10W
R51	1-216-065-00	METAL CHIP	4.7K 5% 1/10W
R52	1-216-061-00	METAL CHIP	3.3K 5% 1/10W
R53	1-216-061-00	METAL CHIP	3.3K 5% 1/10W
R54	1-216-073-00	METAL CHIP	10K 5% 1/10W
R55	1-216-061-00	METAL CHIP	3.3K 5% 1/10W
R57	1-216-162-00	METAL CHIP	33 5% 1/8W
R58	1-216-013-00	METAL CHIP	33 5% 1/10W
R91	1-216-295-91	METAL CHIP	0 5% 1/10W
R92	1-216-073-00	METAL CHIP	10K 5% 1/10W
R1751	1-247-807-31	CARBON	100 5% 1/4W
R1752	1-216-073-00	METAL CHIP	10K 5% 1/10W
R1753	1-216-067-00	METAL CHIP	5.6K 5% 1/10W
R1754	1-216-097-91	METAL CHIP	100K 5% 1/10W
R1755	1-216-097-91	METAL CHIP	100K 5% 1/10W
R1756	1-249-401-11	CARBON	47 5% 1/4W
R1757	1-216-295-91	METAL CHIP	0 5% 1/10W
< VARIABLE RESISTOR >			
RV41	1-238-600-11	RES, ADJ, CARBON 10K	
RV42	1-238-600-11	RES, ADJ, CARBON 10K	
< TERMINAL >			
TM1	1-537-488-11	TERMINAL BOARD (ANT) (ANTENNA)	

Ref. No.	Part No.	Description	Remark
< VIBRATOR >			
X21	1-760-549-11	VIBRATOR, CRYSTAL (4.5MHz)	
X41	1-767-825-21	FILTER, CERAMIC (10.7MHz)	
X42	1-527-981-00	FILTER, CERAMIC (450kHz)	
X1751	1-579-900-21	VIBRATOR, CRYSTAL (4.332MHz)	

*	1-668-208-11	TRANSFORMER BOARD	*****
	1-533-217-31	HOLDER, FUSE	
< CONNECTOR >			
CN11	1-564-523-11	PLUG, CONNECTOR 8P	
* CN12	1-564-518-11	PLUG, CONNECTOR 3P	
CN13	1-564-321-00	PIN, CONNECTOR 2P	
< FUSE >			
△F11	1-532-388-31	FUSE (T2AL/250V) (EXCEPT CND, AEP, UK, G, EE, CIS, MX)	
△F11	1-532-503-31	FUSE (T1.6AL/250V) (AEP, UK, G, EE, CIS)	
△F12	1-532-504-31	FUSE (T4AL/250V) (E2, E3, EA3, MY, SP, IA, HK, TW, SAF, MX, JE)	
△F12	1-533-310-11	FUSE, GLASS TUBE6.3A 125V (CND)	
< RESISTOR >			
△R11	1-219-120-11	FUSIBLE 0.15 5% 1/4W F (GRX7/GRX7J/RX77: CND)	
△R11	1-219-121-11	FUSIBLE 0.22 5% 1/4W F (AEP, UK, G, EE, CIS)	
△R12	1-219-120-11	FUSIBLE 0.15 5% 1/4W F (GRX7/GRX7J/RX77: CND)	
△R12	1-219-121-11	FUSIBLE 0.22 5% 1/4W F (AEP, UK, G, EE, CIS)	
△R13	1-219-120-11	FUSIBLE 0.15 5% 1/4W F (GRX7/GRX7J/RX77: CND)	
△R13	1-219-121-11	FUSIBLE 0.22 5% 1/4W F (AEP, UK, G, EE, CIS)	
△R14	1-219-120-11	FUSIBLE 0.15 5% 1/4W F (GRX7/GRX7J/RX77: CND)	
△R14	1-219-121-11	FUSIBLE 0.22 5% 1/4W F (AEP, UK, G, EE, CIS)	
R15	1-202-725-00	SOLID 3.3M 10% 1/2W (CND)	
< SWITCH >			
△S11	1-572-675-11	SWITCH, POWER VOLTAGE CHANGE (POWER SELECT) (E2, E3, EA3, MY, SP, IA, HK, TW, SAF)	
< TRANSFORMER >			
△T11	1-431-659-11	TRANSFORMER, POWER (CND)	
△T11	1-431-660-11	TRANSFORMER, POWER (AEP, UK, G, EE, CIS)	
△T11	1-431-661-11	TRANSFORMER, POWER (GRX7/GRX7J)	

The components identified by mark △ or dotted line with mark △ are critical for safety. Replace only with part number specified.	Les composants identifiés par une marque △ sont critiques pour la sécurité. Ne les remplacer que par une pièce portant le numéro spécifié.
--	--

HCD-GRX7/GRX7J/R700/RX77/RX77S

Ref. No.	Part No.	Description	Remark
		MISCELLANEOUS *****	
6	1-769-984-11	WIRE (FLAT TYPE) (13 CORE) (23CM)	
10	1-773-048-11	WIRE (FLAT TYPE) (17 CORE)	
11	1-773-025-11	WIRE (FLAT TYPE) (15 CORE) (33CM)	
106	1-783-570-11	WIRE (FLAT TYPE) (19 CORE) (24CM)	
108	1-769-976-11	WIRE (FLAT TYPE) (13 CORE) (14CM) (CND, E2, EA4, TH, MX, AUS)	
108	1-773-008-11	WIRE (FLAT TYPE) (15 CORE) (14CM) (GRX7: E3, EA3, MY, SP, IA, HK, TW, SAF/ GRX7J/R700/RX77: AEP, G, EE/RX77S)	
109	1-233-544-11	ENCAPSULATED COMPONENT (CND)	
109	1-233-545-11	ENCAPSULATED COMPONENT	
109	1-233-546-11	ENCAPSULATED COMPONENT	
109	1-693-385-11	TUNER (JE)	
△ 114	1-575-651-11	CORD, POWER (EA3, EA4, MY, SP, HK, TW, SAF)	
△ 114	1-575-653-11	CORD, POWER (E2, E3, IA, MX, JE)	
△ 114	1-690-608-11	CORD, POWER (AUS)	
△ 114	1-690-609-21	CORD, POWER (CND)	
△ 114	1-751-326-31	CORD, POWER (TH)	
△ 114	1-775-787-71	CORD, POWER (AEP, UK, G, EE, CIS)	
△ 115	1-569-007-11	ADAPTOR, CONVERSION 2P (E3, IA, JE)	
△ 115	1-569-008-11	ADAPTOR, CONVERSION 2P (EA3, MY, SP, TW, SAF)	
△ 115	1-770-019-11	ADAPTOR, CONVERSION PLUG 3P (UK, HK)	
* 257	1-452-879-11	MAGNET (CDM38L-5BD29AL)	
257	1-452-925-21	MAGNET ASSY (CDM38LH-5BD29AL)	
258	1-776-042-11	WIRE (FLAT TYPE) (8 CORE)	
△ 301	8-820-020-02	OPTICAL PICK-UP KSS-213D/Q-NP	
302	1-769-069-11	WIRE (FLAT TYPE) (16 CORE)	
HP101	A-2056-681-A	DECK (A) ASSY, HEAD (230AWR1)	
HP101	A-2056-683-A	DECK (A) ASSY, HEAD (230PWR1)	
HRPE101A-2056-682-A		DECK (B) ASSY, HEAD (230AWR1)	
HRPE101A-2056-684-A		DECK (B) ASSY, HEAD (230PWR1)	
M1	A-2004-628-A	MOTOR ASSY, CAPSTAN	
M101	X-4917-523-4	MOTOR ASSY (SPINDLE)	
M102	X-4917-504-1	MOTOR ASSY (SLED)	
M401	1-698-792-11	FAN, DC (GRX7/GRX7J/RX77: CND)	
M701	A-4672-004-A	MOTOR ASSY (TURN)	
M801	A-4672-004-A	MOTOR ASSY SLIDE)	
S811	1-473-335-11	ENCODER, ROTARY (BU, TRAY ADDRESS DET)	
△ T11	1-431-659-11	TRANSFORMER, POWER (CND)	
△ T11	1-431-660-11	TRANSFORMER, POWER (AEP, UK, G, EE, CIS)	
△ T11	1-431-661-11	TRANSFORMER, POWER (GRX7/GRX7J)	

		HARDWARE LIST	

#1	7-685-872-09	SCREW +BVTT 3X8 (S)	
#2	7-685-646-79	SCREW +BVTP 3X8 TYPE2 N-S	
#3	7-685-647-79	SCREW +BVTP 3X10 TYPE2 N-S	
#4	7-685-650-79	SCREW +BVTP 3X16 TYPE2 IT-3	
#5	7-685-871-01	SCREW +BVTT 3X6 (S)	
#7	7-685-851-04	SCREW +BVTT 2X4 (S)	
#8	7-621-775-10	SCREW +B 2.6X4	

Ref. No.	Part No.	Description	Remark
#9	7-621-255-15	SCREW +P 2X3	
#10	7-685-850-04	SCREW +BVTT 2X3 (S)	
#11	7-628-254-15	SCREW +PS 2.6X6	
#12	7-628-254-50	SCREW +PS 2.6X16	

The components identified by mark △ or dotted line with mark △ are critical for safety. Replace only with part number specified.

Les composants identifiés par une marque △ sont critiques pour la sécurité. Ne les remplacer que par une pièce portant le numéro spécifié.