

# PMC-212

## SERVICE MANUAL

AEP Model

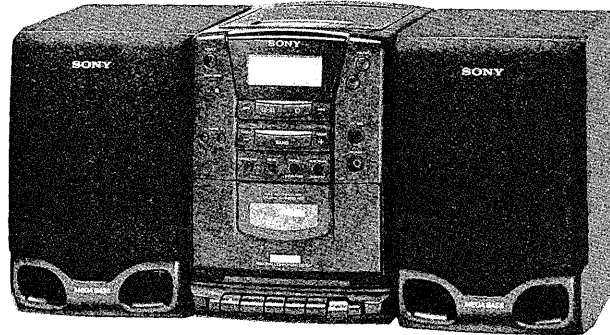

CD Section	Model Name Using Similar Mechanism	CFD-9
	CD Mechanism Type	KSM-213BAN
	Optical Pick-up Name	KSS-213B
TAPE Section	Model Name Using Similar Mechanism	CFD-9
	Tape Transport Mechanism Type	MF-PMC212

### SPECIFICATIONS

#### CD player section

- System**  
Compact disc digital audio system
- Laser diode properties**  
Material: GaAlAs  
Wave length: 780 nm  
Emission duration: Continuous  
Laser output: Less than 44.6  $\mu$ W (This output is the value measured at a distance of about 200 mm from the objective lens surface on the optical pick-up block with 7 mm aperture.)
- Spindle speed**  
200 r/min (rpm) to 500 r/min (rpm) (CLV)
- Number of channels**  
2
- Frequency response**  
20 - 20,000 Hz +1/-2 dB
- Wow and flutter**  
Below measurable limit

#### Radio section

- Frequency range**
- FM: 87.6 - 107 MHz (AEP model)  
87.5 - 108 MHz (Italian model)  
AM: 531 - 1,602 kHz
- IF**  
FM: 10.7 MHz  
AM: 450 kHz
- Aerials**  
FM: External aerial terminals  
AM: External aerial terminals

#### Cassette-corder section

- Recording system**  
4-track 2 channel stereo
- Fast winding time**  
Approx. 120s (sec.) with Sony cassette C-60
- Frequency response**  
TYPE I (normal): 80 - 14,000 Hz  
TYPE II (high position): 80 - 15,000 Hz
- General**
- Speaker**  
Full range: 10 cm (4 in.) dia., cone type
- Inputs**  
Mixing microphone input jack (minijack):  
Sensitivity 2.5 mV  
For low impedance microphone
- Outputs**  
Headphones jack (stereo minijack)  
For 16 - 68 ohms impedance headphones
- Maximum power output**  
30 W + 30 W
- Power requirements**  
For personal component system:  
220 - 230 V AC, 50 Hz  
For remote commander:  
3 V DC, 2 R6 (size AA) batteries

- Power consumption**  
AC 48 W
- Dimensions**  
Unit: approx. 160 x 237 x 292.5 mm (w/h/d)  
(6 3/8 x 9 3/8 x 11 3/8 inches)  
Speaker: approx. 150 x 230 x 240 mm (w/h/d)  
(6 x 9 1/8 x 9 1/2 inches)  
(incl. projecting parts and controls)
- Mass**  
approx. 9.4 kg (20 lb. 12 oz)
- Supplied accessories**  
Remote control (1)  
AM loop aerial (1)  
FM aerial (1)
- Design and specifications are subject to change without notice.

PERSONAL COMPONENT SYSTEM  
**SONY**®

## SERVICING NOTES

### TABLE OF CONTENTS

<b>SERVICING NOTES</b> .....	2
<b>1. GENERAL</b> .....	3
<b>2. DISASSEMBLY</b> .....	15
<b>3. MECHANICAL ADJUSTMENTS</b> .....	17
<b>4. ELECTRICAL ADJUSTMENTS</b>	
Tape Deck Section .....	17
Tuner Section .....	19
CD Section .....	20
<b>5. DIAGRAMS</b>	
5-1. Block Diagram (CD, SYSTEM CONTROL Section) ...	24
5-2. Block Diagram (Main Section) .....	27
5-3. Printed Wiring Boards (CD, SYSTEM CONTROL Section) .....	30
5-4. Schematic Diagram (CD, SYSTEM CONTROL Section) .....	33
5-5. Schematic Diagram (MAIN Section) .....	38
5-6. Printed Wiring Boards (MAIN Section) .....	43
5-7. IC Pin Function Description .....	49
<b>6. EXPLODED VIEWS</b> .....	52
<b>7. ELECTRICAL PARTS LIST</b> .....	59

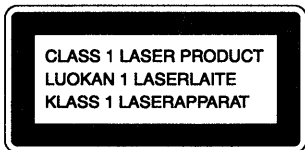

This Compact Disc player is classified as a CLASS 1 LASER product. The CLASS 1 LASER PRODUCT label is located on the rear exterior.

#### CAUTION

Use of controls or adjustments or performance of procedures other than those specified herein may result in hazardous radiation exposure.

#### SAFETY-RELATED COMPONENT WARNING!!

COMPONENTS IDENTIFIED BY MARK  $\Delta$  OR DOTTED LINE WITH MARK  $\Delta$  ON THE SCHEMATIC DIAGRAMS AND IN THE PARTS LIST ARE CRITICAL TO SAFE OPERATION. REPLACE THESE COMPONENTS WITH SONY PARTS WHOSE PART NUMBERS APPEAR AS SHOWN IN THIS MANUAL OR IN SUPPLEMENTS PUBLISHED BY SONY.

#### CHUCK PLATE JIG ON REPAIRING

On repairing CD section, playing a disc without the CD lid, use Chuck Plate Jig.

• Code number of Chuck Plate Jig: X-4918-255-1

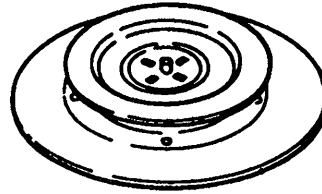

#### NOTES ON HANDLING THE OPTICAL PICK-UP BLOCK OR BASE UNIT

The laser diode in the optical pick-up block may suffer electrostatic breakdown because of the potential difference generated by the charged electrostatic load, etc. on clothing and the human body.

During repair, pay attention to electrostatic breakdown and also use the procedure in the printed matter which is included in the repair parts.

The flexible board is easily damaged and should be handled with care.

#### NOTES ON LASER DIODE EMISSION CHECK

The laser beam on this model is concentrated so as to be focused on the disc reflective surface by the objective lens in the optical pick-up block. Therefore, when checking the laser diode emission, observe from more than 25 cm away from the objective lens.

#### LASER DIODE AND FOCUS SEARCH OPERATION CHECK

1. Turn POWER switch on with no disc inserted and make Function switch to CD position.
2. Open the lid for CD.
3. Turn on S701 as following figure.
4. Press the  $\blacktriangleright\parallel$  button.
5. Confirm the laser diode emission while observing the objecting lens. When there is no emission, Auto Power Control circuit or Optical Pick-up is broken. Objective lens moves up and down three times for the focus search.

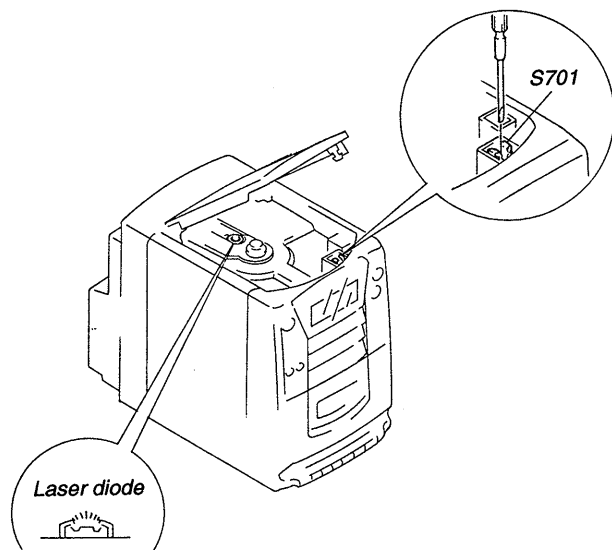

## Playing a CD

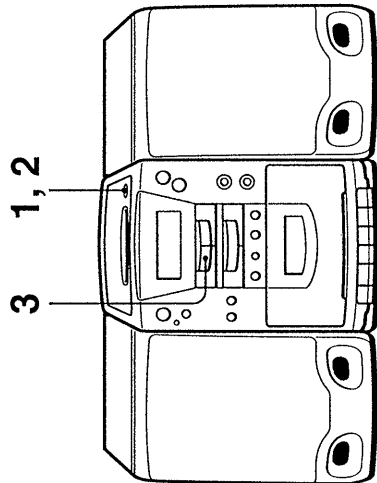

For hookup instructions, see pages 20 - 23.

1



PUSH OPEN

Press **▲ PUSH OPEN** down to open the disc compartment and place the disc on the disc compartment.

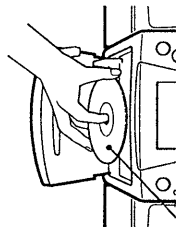

With the label side up

2



PUSH OPEN

Close the lid of the disc compartment.

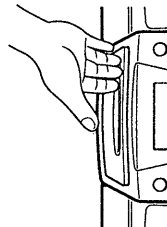

3



Press **▶||** (direct power-on). The player plays all the tracks once.

Display



Track number    Playing time

### Tip

Next time you want to listen to a CD, just press **▶||**. The player turns on automatically and starts playing the CD.

Use these buttons for additional operations

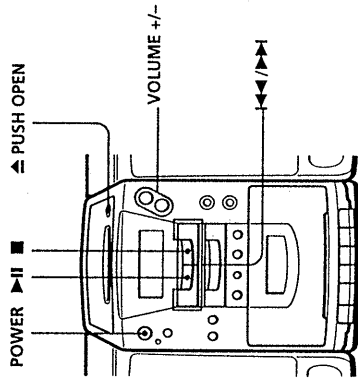

To	Press
Adjust the volume	VOLUME +/-
Stop playback	■
Pause playback	▶   Press again to resume play after pause.
Go to the next track	▶▶
Go back to the previous track	◀◀
Remove the CD	▲ PUSH OPEN
Turn on/off the player	POWER

## SECTION 1 GENERAL

This section is extracted from instruction manual.

# Listening to the radio

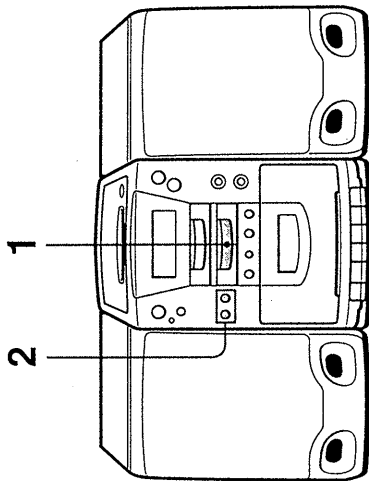

For hookup instructions, see pages 20 - 23.



Display

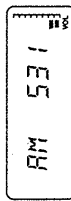

1 Press **BAND** until the band you want appears in the display (direct power-on).

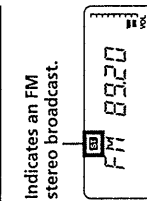
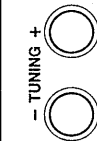

2 Hold down **TUNING+/-** until the frequency digits begin to change in the display. The player automatically scans the radio frequencies and stops when it finds a clear station. If you can't tune in a station, press the button once at a time.

Indicates an FM stereo broadcast.

Use these buttons for additional operations

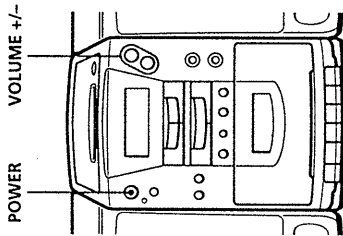

To	Press
Adjust the volume	VOLUME +/-
Turn on/off the radio	POWER

## To improve broadcast reception FM (PMC-212 only)

Connect the FM outdoor aerial (not supplied) (see page 23.)

## AM

Reorient the AM loop aerial (supplied).

*PMC-202 only:* If the AM broadcast is still noisy, connect an insulated wire (not supplied) to the AM terminal (see page 23.)

## Tips

- If the FM broadcast is noisy, press **PLAY MODE/MONO/ST** until "Mono" appears in the display and the radio will play in monaural.
- Next time you want to listen to the radio, just press the **BAND** button. The player turns on automatically and starts playing the previous station.
- If you need to change the AM tuning interval (preset to 9 kHz at the factory), see page 22. (excluding models for Europe)

## Playing a tape

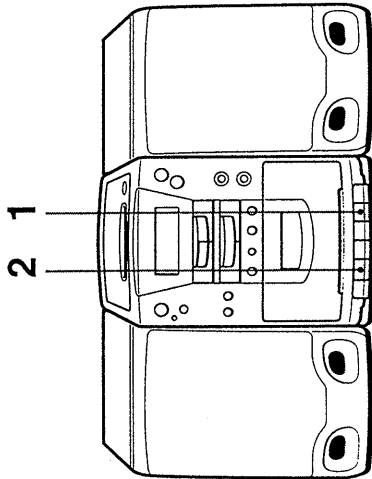

For hookup instructions, see pages 20 - 23.

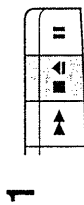

Press to open the tape compartment and insert a recorded tape. Use TYPE I (normal), TYPE II (high position) and TYPE IV (metal) tapes. Close the compartment.

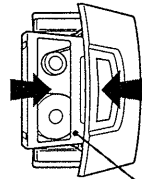

With the side you want to play facing forward.



Press The player turns on (direct power-on) and starts playing.

Use these buttons for additional operations

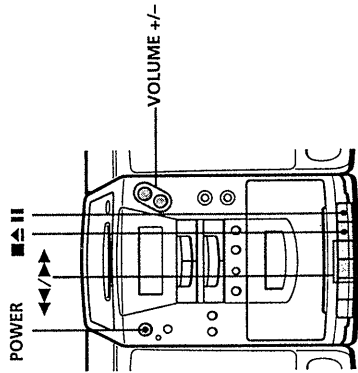

## Basic Operations

To	Press
Adjust the volume	VOLUME +/-
Stop playback	
Fast-forward or rewind the tape	or
Pause playback	
Press the button again to resume play after pause.	
Eject the cassette	
Turn on/off the player	POWER

**Tip** Next time you want to listen to a tape, just press . The player turns on automatically and starts playing the tape.

# Recording on a tape

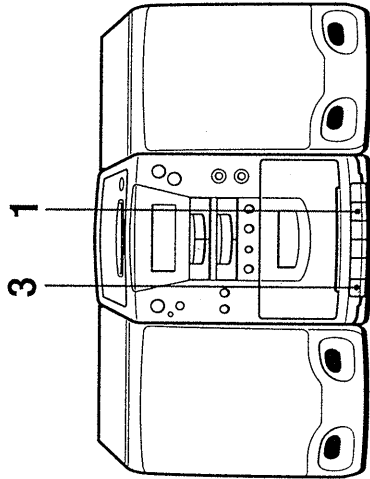

For hookup instructions, see pages 20 - 23.

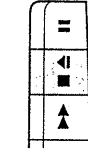

Press to open the tape compartment and insert a blank tape. Use TYPE I (normal) and TYPE II (high position) tapes only.

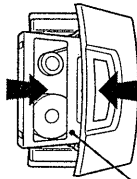

With the side you want to record on facing forward

## 2

Select the program source you want to record.

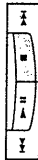

To record from the CD player, insert a CD (see page 4) and press on the CD section.

Display

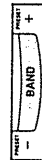
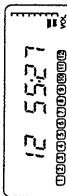

To record from the radio, press BAND and tune in the station you want (see page 6.)

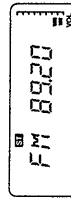

## 3

Press to start recording. ( is depressed automatically.)



Use these buttons for additional operations

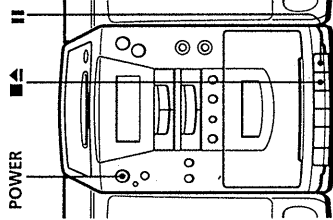

To	Press
Stop recording	
Pause recording	
Turn on/off the player	POWER

### Note

If the AM program makes a whistling sound after you've pressed in step 3, move the AM loop aerial connected to the player as far away as possible.

### Tips

- Adjusting the volume or the audio emphasis (see page 24) will not affect the recording level.
- To erase a recording, proceed as follows:
  - Disconnect the microphone if connected at the MIX MIC jack.
  - Turn on the power and then press FUNCTION on the remote until "TAPE" appears in the display window.
  - Press .

## Using the display

You can check information about the disc using the display.

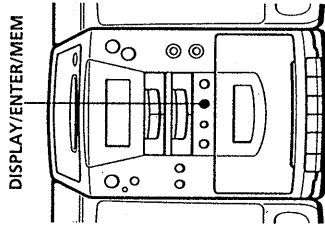

### Checking the total track numbers and playing time

Press DISPLAY/ENTER/MEM in stop mode. If the disc has more than 12 tracks, "OVER 12" appears in the display.

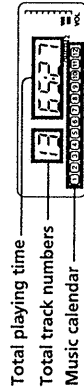

### Checking the remaining time

Press DISPLAY/ENTER/MEM while playing a disc. The track numbers in the music calendar disappear after they are played.

\* For a track whose number is more than 21 the remaining time appears as "--:--".

To display	Press DISPLAY/ENTER/MEM
Remaining time on the current track*	Once
Remaining time on the disc and the number of tracks left	Twice
Playing time and the current track number	Three times

## Locating a specific track

You can quickly locate any track using the number buttons. You can also find a specific point in a track while playing a disc.

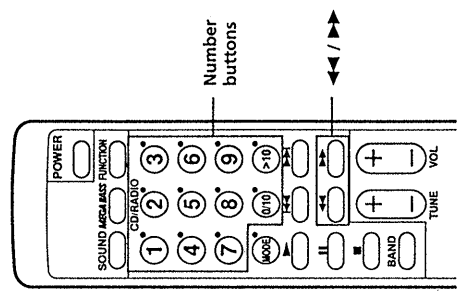

To locate	Press
a specific track directly	a number button of the track.
a point while listening to the sound	▶▶ (forward) or ◀◀ (backward) while playing and hold down until you find the point. When you use the buttons on the player, use ◀◀/▶▶▶.
a point while observing the display	▶▶ (forward) or ◀◀ (backward) in pause and hold down until you find the point. When you use the buttons on the player, use ◀◀/▶▶▶.

**Note**  
You cannot start play if "PCM" or "SHUF REP" is lit in the display. Turn off the indication by pressing ■.

**Tip**  
When you locate a track numbered over 10, press > 10 first, then the corresponding number buttons.  
Example:  
To play track number 23, press >10 first, then 2 and 3.

## Playing tracks repeatedly (Repeat Play)

You can play tracks repeatedly in normal, shuffle or program play modes (see pages 15 – 16.)

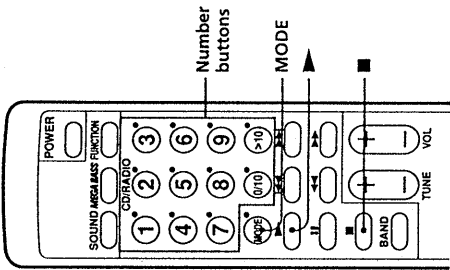

### Playing tracks repeatedly

- 1 Press ■. "CD" appears in the display.
- 2 Press MODE until the repeat mode you want appears in the display.

To repeat	Select
a single track	REP 1
all the tracks	REP ALL
tracks in random order	SHUF REP
programmed tracks	PGM REP and then program tracks (see step 3 on page 15).

- 3 Do either of the following to start repeat play:
  - When you've selected REP1, select the track by pressing the number button.
  - When you've selected REP ALL, SHUF REP or PGM REP, press ►.

## Creating your own program (Program Play)

You can make a program of up to 20 tracks in the order you want them to be played.

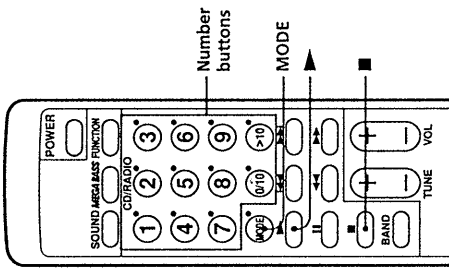

- 1 Press ■. "CD" appears in the display.
- 2 Press MODE until "PGM" appears in the display.
- 3 Press the number buttons for the tracks you want to program in the order you want. You can program up to 20 tracks.

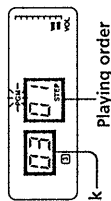

- 4 Press ► to start program play.

continued

## Creating your own program (Program Play) (continued)

### To cancel Program Play

Press MODE until no indication appears in the display.

### To check the order of tracks before play

Press DISPLAY/ENTER/MEM on the player. Every time you press the button, the track number appears in the programmed order.

### To change the current program

Press **■** once if the CD is stopped and twice if the CD is playing. The current program will be erased. Then create a new program following the programming procedure.

## The Radio

# Presetting radio stations

You can store radio stations into the player's memory. You can preset up to 24 radio stations, 12 for each band in any order.

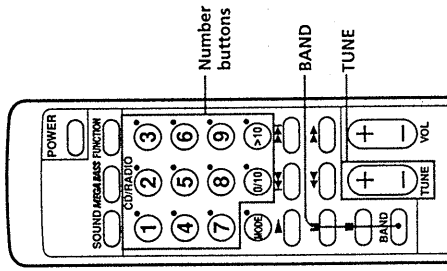

## The Radio

### Tip

To preset radio stations on the player, proceed as follows:

- 1 Select the band and tune in a station you want.
- 2 Hold down DISPLAY/ENTER/MEM for about 2 seconds. "PRESET" and a preset number flash.
- 3 Decide on a preset number for the station (1 to 12) by pressing PRESET +/-.
- 4 Press DISPLAY/ENTER/MEM.

- 1 Press BAND until the band you want appears in the display.

- 2 Tune in a station you want.

- 3 Hold down the number buttons that you want to preset the new station for about 2 seconds.

To select the preset number over 10, press >10 first, then the corresponding number buttons. You need to hold down the last number button to enter for about 2 seconds. (Example: To select 12, press >10 and 1, then hold down 2 for about 2 seconds.)

The new station replaces the old one.

## Playing preset radio stations

Once you've preset the stations, use the number buttons to tune in your favorite stations.

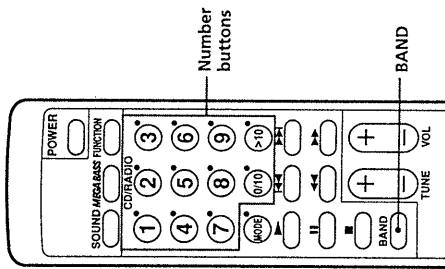

**Tip**  
You can tune in a preset station on the player. Use PRESET +/- instead of the number buttons.

- 1 Press BAND to select the band.
- 2 Press the number buttons to tune in a stored station.  
To tune in a preset station over 10, press >10 first, then the corresponding number buttons.  
(Example: To tune in a preset station 11, press >10, and then press 1 and 1.)

## Recording a microphone/Using as a PA system

You can record sound using a microphone (not supplied) or use the player as a public address system.

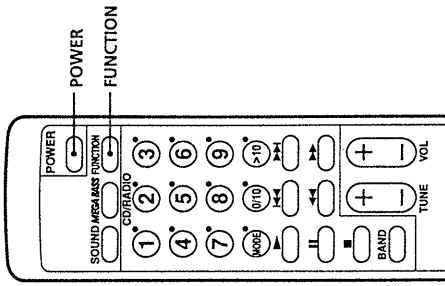

### Recording through a microphone

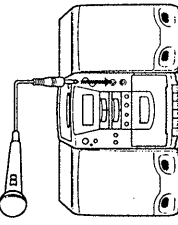

- 1 Plug the microphone into the MIX MIC jack and turn on the microphone if it has a power switch.
- 2 Turn on the power.
- 3 Press FUNCTION until "TAPE" appears in the display.
- 4 Insert a cassette for recording into the deck and press ● to start recording.

### Using as a PA system

- 1 Do steps 1 – 3 above.
- 2 Sing or speak into the microphone and adjust the volume.

**Tip**  
You can mix CD or radio sounds and record them by adding your voice or other audio through the microphone.

### Notes

- Acoustic feedback (howling) tends to occur when you use a microphone with echo function.
- If acoustic feedback (howling) occurs, turn down the volume or move the microphone away from the speaker.

## Hooking up the system

Make sure you turn off the power before making any connections.

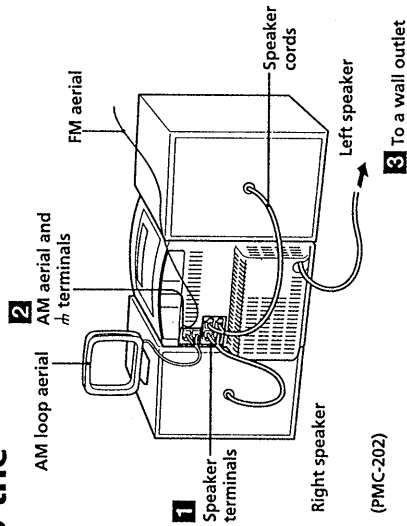

### Note

Connect the speakers for this unit only to the speaker terminals of this unit. If you connect any other speakers or equipment, malfunction may occur.

### 1 Hooking up the speakers

- 1 Twist the speaker cable coating and strip it from the end of the cable.
- 2 Connect the black wires to (-) minus and the red wires to (+) plus terminals; the right speaker wires to the R and the left speaker wires to the L terminals.

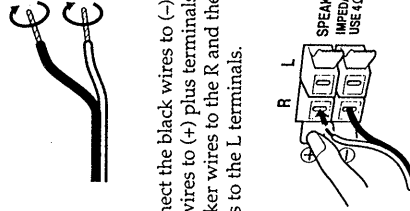

### 2 Hooking up the aerials

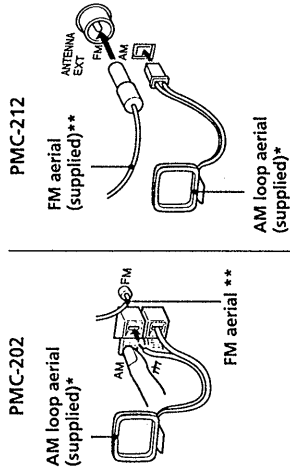

\*Reorient the aerial to improve broadcast reception.  
 \*\*Keep the aerial as horizontal as possible.

### Setting up the AM loop aerial



### 3 Connecting the AC power cord

Connect the supplied AC power cord to the wall outlet.

The POWER STANDBY indicator lights up to indicate when the player is connected to the power source. The indicator lights regardless of whether the power is on or off.

### Setting the MAIN POWER switch (for European model only)

Before hooking up the speakers, set the MAIN POWER switch on the side of the player to ON.

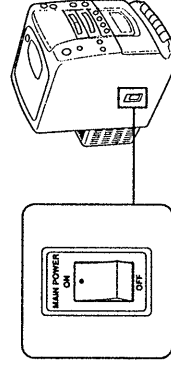

### Note

Keep the antennas away as far as possible from the speaker cords and other connecting cords. If you do not, noise may be heard.

### Tip

Only for the customers supplied with an AC plug adaptor:

Use the supplied AC plug adaptor if the plug of the AC power cord does not match your outlet.

### Note

For European model only:

Be sure to turn off the power of the player before you set the MAIN POWER switch to OFF.

When you set the MAIN POWER switch to ON again and turn on the player, the player function will be set to "CD" automatically.

## Hooking up the system (continued)

### Adjusting the voltage (excluding models for Europe)

Be sure to set the VOLTAGE SELECTOR (on the bottom) to your local power supply.

VOLTAGE SELECTOR  
110 - 120V      220 - 240V



### Changing the AM tuning interval (excluding models for Europe)

If you need to change the AM tuning interval (preset to 9 kHz at the factory), do the following:

- 1 Disconnect the power cord and remove all the batteries.
- 2 Press the POWER switch for about 3 seconds.
- 3 Set the AM tuning interval selector (on the bottom). After changing the tuning interval, you need to reset preset radio stations.

### 4 Inserting batteries into the remote

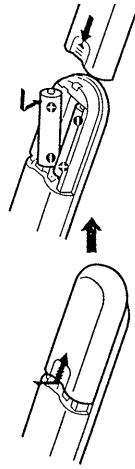

Insert two R6 (size AA) batteries (not supplied)

### Replacing batteries

With normal use, the batteries should last for about six months. When the remote no longer operates the player, replace all the batteries with new ones.

### Important

When you use an outdoor aerial, be sure to connect the  $\#$  terminal to earth against lightning. To prevent a gas explosion, do not connect the ground wire to a gas pipe.

**To improve the FM reception (PMC-212 only)**  
Disconnect the supplied FM aerial and connect the FM outdoor aerial (not supplied). If you use a distributor, you can also use the TV aerial.

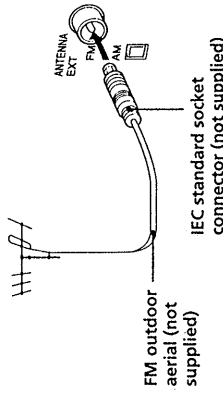

**To improve the AM reception (PMC-202 only)**  
Connect a 6- and 15- meter insulated wire (not supplied) to the AM terminal. Keep the wire as horizontal as possible near the window or outdoor. You do not need to disconnect the supplied AM loop aerial.

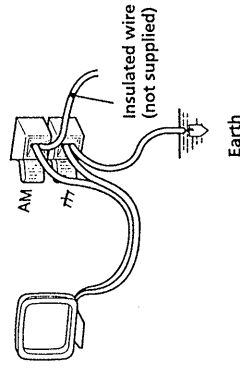



## Precautions (continued)

### Notes on CDs

- Before playing, clean the CD with a cleaning cloth. Wipe the CD from the center out.



- Do not use solvents such as benzene, thinner, commercially available cleaners or anti-static spray intended for vinyl LPs.
- Do not expose the CD to direct sunlight or heat sources such as hot air ducts, nor leave it in a car parked in direct sunlight as there can be a considerable rise in temperature inside the car.
- After playing, store the CD in its case. If there is a scratch, dirt or fingerprints on the CD, it may cause tracking error.

### Notes on cassettes

- Break off the cassette tab from side A or B to prevent accidental recording. If you want to reuse the tape for recording, cover the broken tab with adhesive tape.

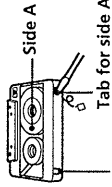

- To record on a tape with its tab broken off, cover the respective tab hole for side A or B with adhesive tape.
- The use of a cassette with more than 90 minutes of play time is not recommended except for long, continuous recording or playback.

## Maintenance

### Cleaning the tape heads and tape path

Wipe the heads, the pinch rollers and the capstans with a cleaning swab slightly moistened with cleaning fluid or alcohol after every 10 hours of operation for optimum playback and recording quality. To make the best possible recording, however, we recommend that you clean all surfaces over which tape travels before each recording.

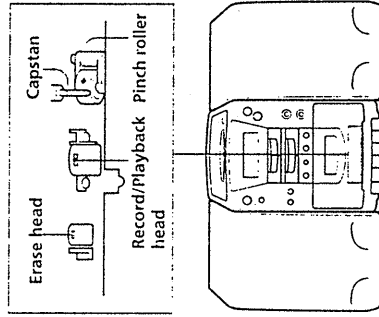

After cleaning, insert a tape when the areas cleaned are completely dry.

### Demagnetizing the tape heads

After 20 to 30 hours of use, enough residual magnetism will have built up on the tape heads to begin to cause loss of high frequency sound and hiss. At this time, you should demagnetize the heads and all metal parts in the tape path with a commercially available tape head demagnetizer.

### Cleaning the cabinet

Clean the cabinet, panel and controls with a soft cloth slightly moistened with a mild detergent solution. Do not use any type of abrasive pad, scouring powder, or solvent, such as alcohol or benzine.

## SECTION 2 DISASSEMBLY

Note: Follow the disassembly procedure in the numerical order given.

### FRONT CABINET ASS'Y

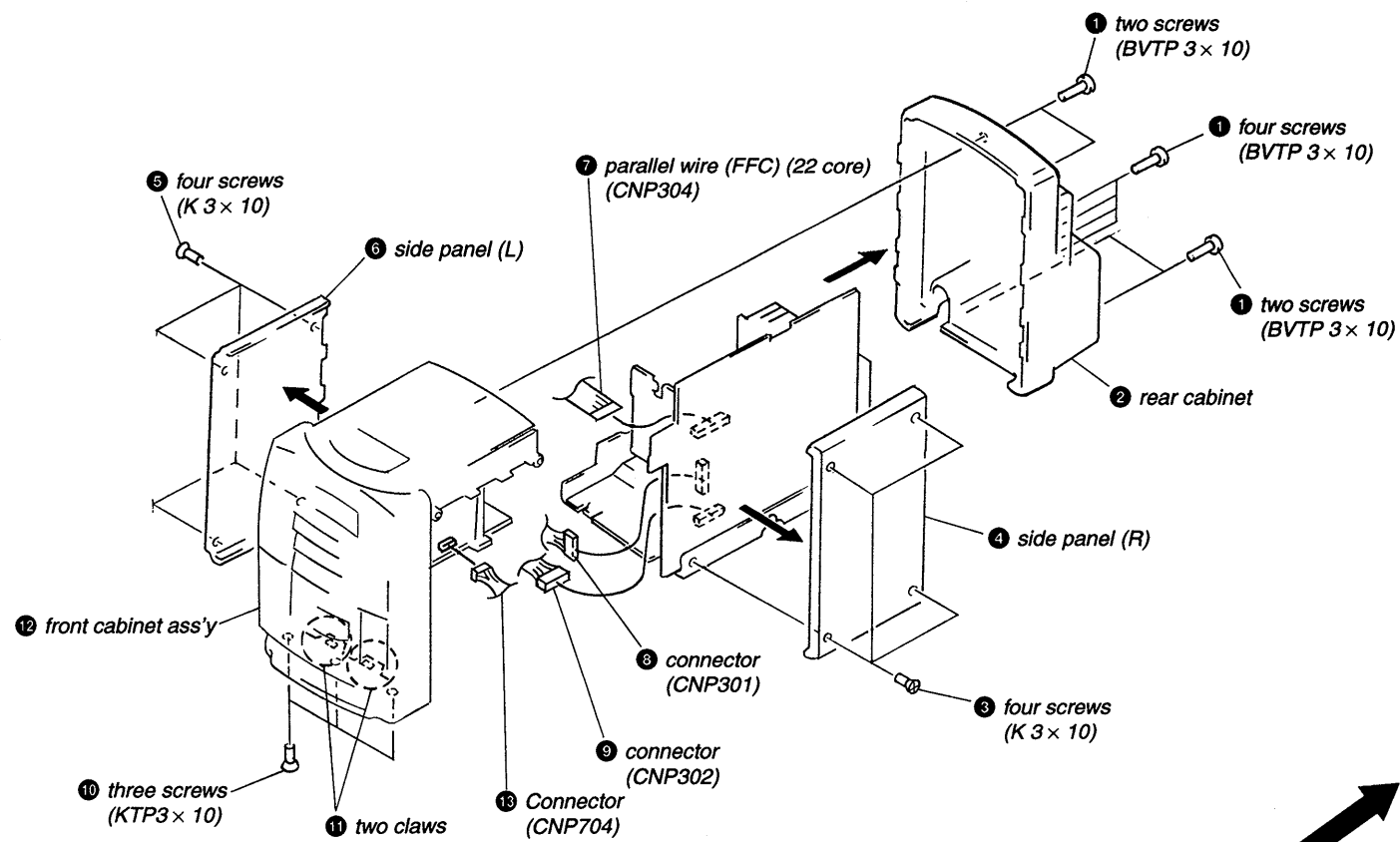

### CD BLOCK ASS'Y

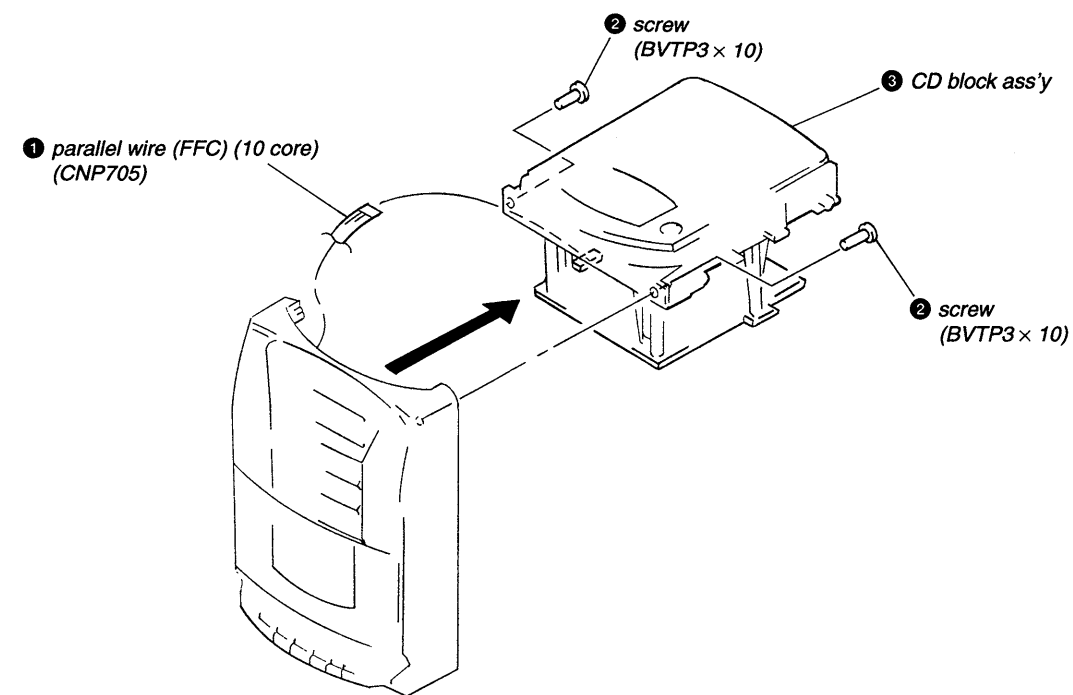

### MECHANISM DECK BLOCK ASS'Y

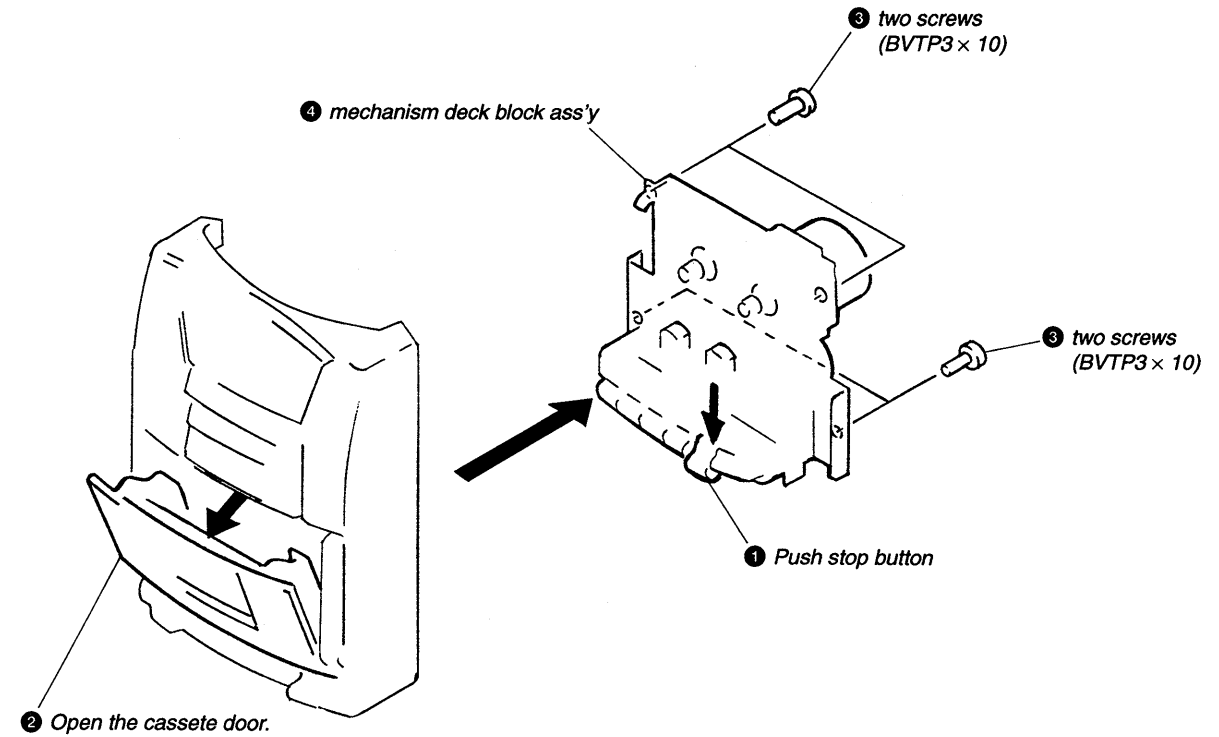

### CHUCKING PLATE

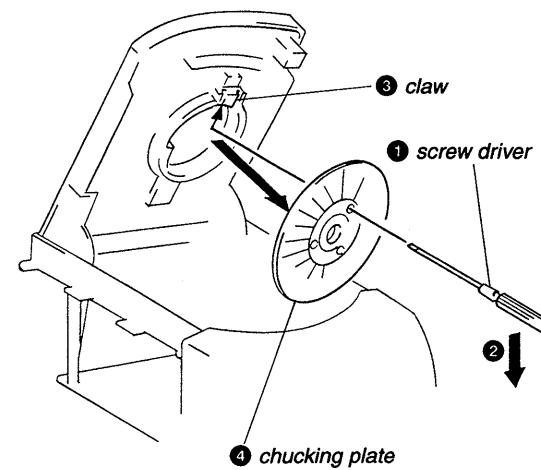

### CD DOOR ASS'Y, CD BOARD, OPTICAL PICK-UP SECTION

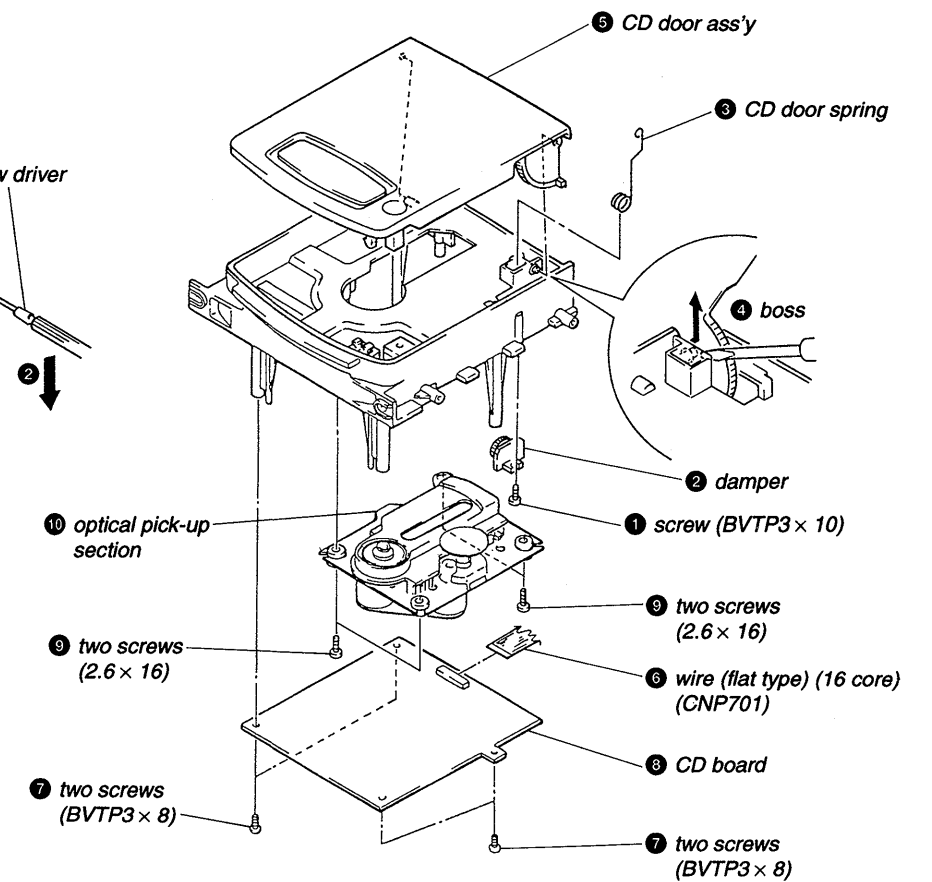

## SECTION 3 MECHANICAL ADJUSTMENTS

### PRECAUTION

1. Clean the following parts with a denatured-alcohol-moistened swab:
 

record/playback head	pinch roller
erase head	rubber belts
capstan	idlers
2. Demagnetize the record/playback head with a head demagnetizer. (Do not bring the head demagnetizer close to the erase head.)
3. Do not use a magnetized screwdriver for the adjustments.
4. After the adjustments, apply suitable locking compound to the parts adjusted.
5. The adjustments should be performed with the rated power supply voltage unless otherwise noted.

### Torque Measurement

Mode	Torque Meter	Meter Reading
FWD	CQ-102C	30-80 g•cm (0.42-1.12 oz•inch)
FWD Back tension		1.5-5.5 g•cm (0.021-0.07 oz•inch)
FF	CQ-201B	50-130 g•cm (0.77-1.80 oz•inch)
REW	CQ-201B	50-130 g•cm (0.77-1.80 oz•inch)

### Tape Tension Measurement

Mode	Tension Meter	Meter Reading
FWD	CQ-403A	more than 100 g (3.53 oz)

## SECTION 4 ELECTRICAL ADJUSTMENTS

### TAPE DECK SECTION

0 dB=0.775 V

1. The adjustments should be performed in the order given in the service manual. (As a general rule. Playback circuit adjustment should be completed before performing recording circuit adjustment.)
2. The adjustments should be performed for both L-ch and R-ch unless otherwise indicated.

### Standard Output Level

	SP OUT	PHONES
Load impedance	6Ω	32Ω
Output level	0.775 V (0 dB)	0.25 V (-10 dB)

### Test Tape

Type	Signal	Used for
WS-48B	3 kHz, 0 dB	Tape speed adjustment
P-4-A063	6.3 kHz, -10 dB	Head azimuth adjustment

### Record/Playback Head Azimuth Adjustment

#### Procedure:

1. Mode: playback

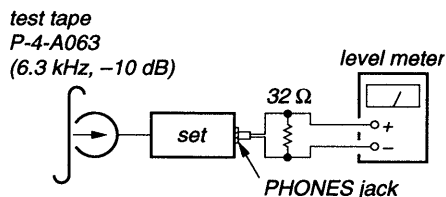

2. Turn the adjustment screw for the maximum output levels. If these levels do not match, turn the adjustment screw until both of output levels match together within 1 dB.

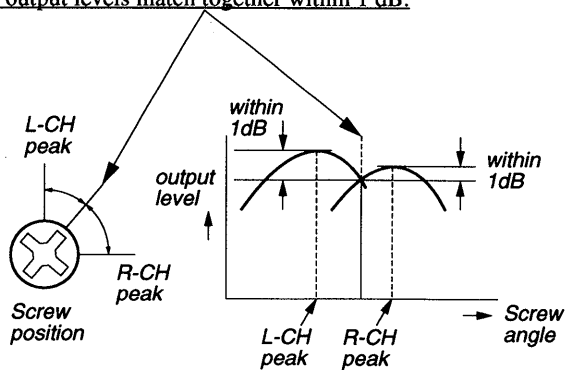

3. Phase Check  
Mode: playback

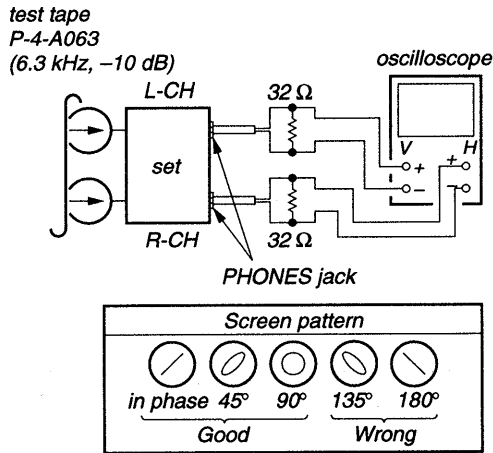

4. After the adjustment, lock the screws with locking compound.

Adjustment Location:

Remove the cassette door

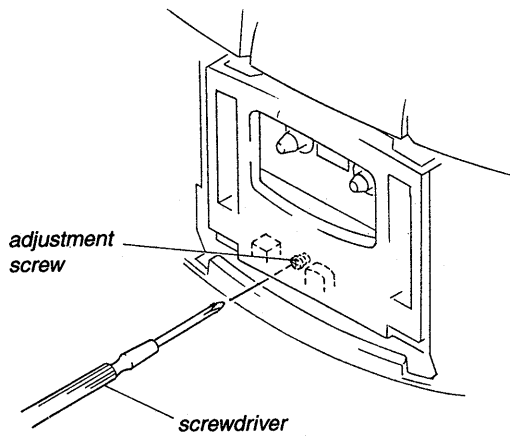

Tape Speed Adjustment

Procedure:

Mode: playback

Adjustment Values:

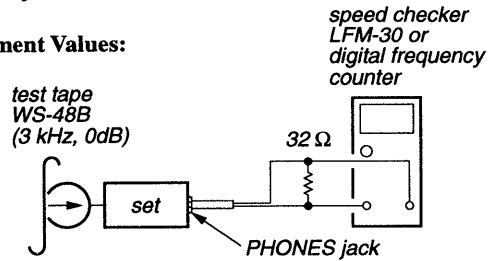

Speed checker	Digital frequency counter
-1% to +1%	2,970 to 3,030 Hz

Frequency difference between the beginning and the end of the tape should be within 1% (30 Hz).

Adjustment Location:

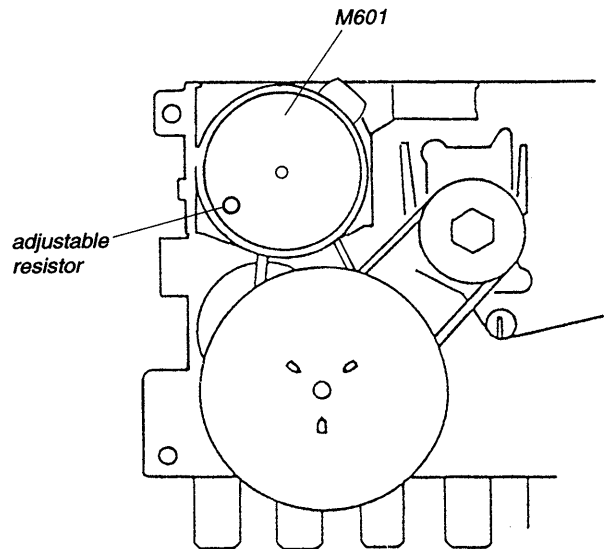

**TUNER SECTION**

[AM]

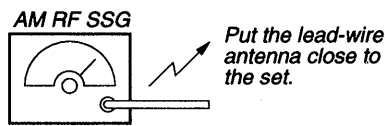

30% amplitude modulation by 400 Hz signal  
output level: as low as possible

[FM]

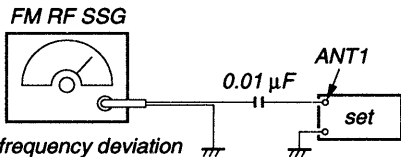

22.5 kHz frequency deviation by 400 Hz signal.  
output level: as low as possible

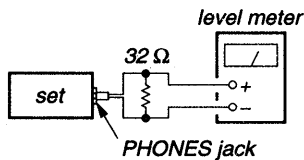

**Adjustment Location:**

[MAIN BOARD]  
(COMPONENT SIDE)

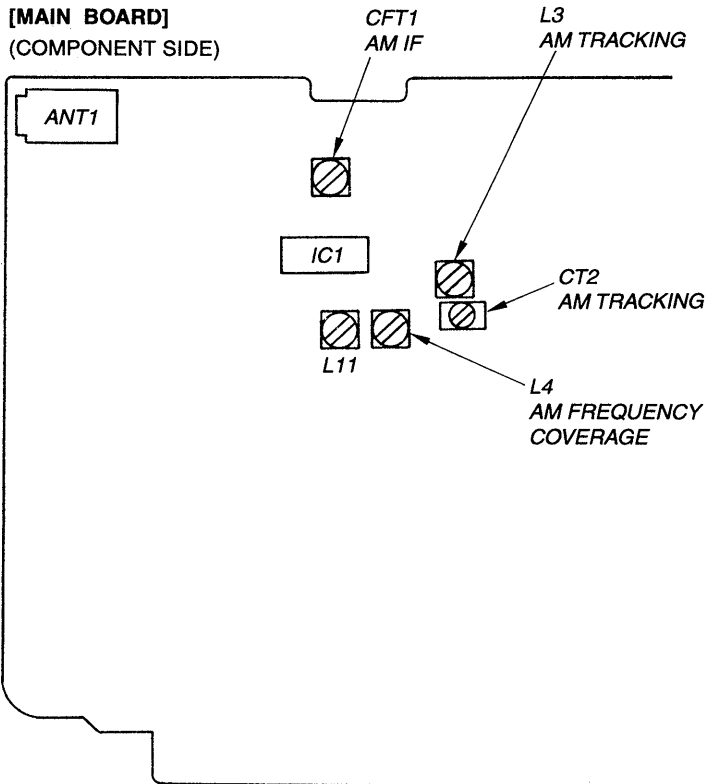

[MAIN BOARD]  
(CONDUCTOR SIDE)

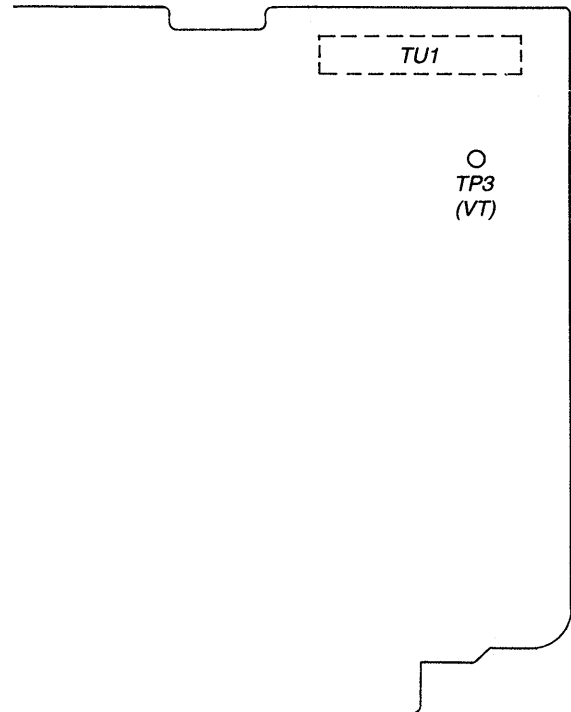

- Repeat the procedures in each adjustment several times, and the frequency coverage and tracking adjustments should be finally done by the trimmer capacitors.

AM IF ADJUSTMENT	
Adjust for a maximum reading on level meter.	
CFT1	450 kHz

AM (TUNNING VOLTAGE) ADJUSTMENT	
Adjust for F MIN: VT 1.0V on voltage meter. F MAX: VT 5.0V	
L4	531 kHz (VT 1.0)
	1,611 kHz (VT 5.0)

AM TRACKING ADJUSTMENT	
Adjust for a maximum reading on level meter.	
L3	612 kHz
CT2	1,404 kHz

## CD SECTION

### Notes on Adjustment

1. Perform adjustment in test mode.  
After adjustments, be sure to release test mode.
2. Perform adjustments in the order given.
3. Use the disc (YEDS-18, Part No. 3-702-101-01) only when so indicated.

### How to Put the Set into Test Mode

1. Disconnect an AC plug cord. (Power is not applied to the set.)
2. Solder across the TEST1 terminal.
3. Close the lid for CD.
4. Connect an AC plug cord.

### [CONTROL BOARD] (Conductor Side)

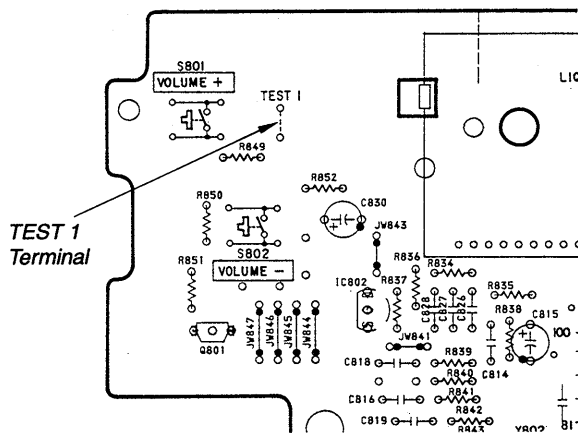

### How to Release the Test Mode

1. Be sure to disconnect the AC plug cord and remove the solder bridge at the TEST1 terminal connected before in setting.
2. The set thus becomes available for normal operation

### Before Beginning Adjustment

Put the set into test mode and perform the following checks.  
Repair if there are any problems.

#### • Sled Motor Check

Press the ►►, ◄◄ buttons and confirm that the optical pick-up moves smoothly from the innermost to outermost circumference and back smoothly and with no catching or abnormal noises.

- : Optical pick-up moves to the outer circumference
- ◄◄ : Optical pick-up moves to the inner circumference

#### • Focus Search Check

1. Press the ►► button. (Focus search operation is performed continuously.)
2. Look at the optical pick-up objective lens and confirm that it moves up and down smoothly, when no catching or abnormal noises.
3. Press the ■ button.  
Confirm that focus search operation stops. If it does not, press the ■ button again longer.

**Note:** When the malfunction is occurred by mis-passing other keys, turn off the power and check again from making the test mode.

### E-F Balance Adjustment

This adjustment is to be done when the optical pick-up is replaced.

#### Procedure:

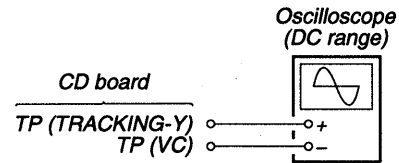

1. Connect the oscilloscope to TP (TRACKING-Y) and TP (VC) on the CD board.
2. Insert the disc (YEDS-18) in and close the lid for CD.
3. Put the set into test mode.
4. Press the ►► and ◄◄ buttons to move the optical pick-up to the center.
5. Press the ►► button.  
[From focus searching, focus is turned ON while entering CLV drawing-in mode. Tracking and sled are turned OFF.]
6. Adjust RV703 so that the oscilloscope traverse waveform is symmetrical, as shown in the figure below.

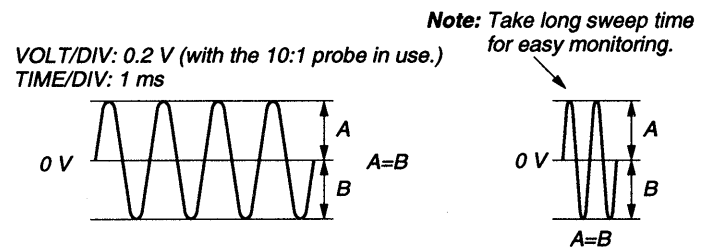

**Adjustment value:**  $0.4 \pm 0.2$  Vp-p (A + B)

7. Release the test mode after adjustment is completed.

**Adjustment Location:** CD board (See page 23.)

## Focus Bias Adjustment

This adjustment is to be done when the optical pick-up is replaced.

### Procedure:

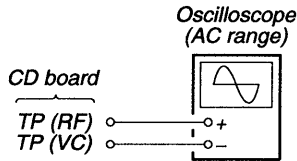

1. Connect the oscilloscope TP (RF) and TP (VC) on the CD board.
2. Insert the disc (YEDS-18) in and close the lid for CD.
3. Put the set into test mode. (See page 20.)
4. Press ►► and ◀◀ buttons to move the optical pick-up to the center. (Move the optical pick-up to the music area on the disc to enable easy visibility of the eye pattern.)
5. Press the ►|| button.
 

From focus searching, focus is turned ON while entering CLV drawing-in mode. Tracking and sled are turned OFF.
6. Press the PLAY MODE button.
 

[Both tracking and sled are turned ON.]
7. Adjust RV701 so that the oscilloscope waveform is as shown in the figure below. (eye pattern)  
A good eye pattern means that the diamond shape (◇) in the center of the waveform can be clearly distinguished.

### • RF signal reference waveform (eye pattern)

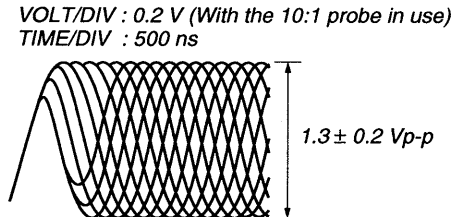

When observing the eye pattern, set the oscilloscope for AC range and raise vertical sensitivity.

8. Release the test mode after adjustment is completed.

**Adjustment Location:** CD board (See page 23.)

## REFERENCE

### Focus/Tracking Gain Adjustment

A frequency response analyzer is necessary in order to perform this adjustment exactly.

However, this gain has a margin, so even if it is slightly off, there is no problem. Therefore, do not perform this adjustment.

Focus/tracking gain determines the pick-up follow-up (vertical and horizontal) relative to mechanical noise and mechanical shock when the 2-axis device operate.

However, as these reciprocate, the adjustment is at the point where both are satisfied.

- When gain is raised, the noise when the 2-axis device operates increases.
- When gain is lowered, mechanical shock and skipping occurs more easily.
- When gain adjustment is off, the symptoms below appear.

	Gain	Focus	Tracking
<b>Symptoms</b>			
• The time until music starts becomes longer for ■→►   on automatic selection. (◀◀, ►► buttons pressed.) (Normally takes about 2 seconds.)		low	low or high
• Music does not start and disc continues to rotate for ■→►   or automatic selection. (◀◀, ►► buttons pressed.)		–	low
• Sound is interrupted during PLAY. Or time counter display stops progressing.		–	low
• More noise during 2-axis device operation.		high	high

The following is a simple adjustment method.

**– Simple Adjustment –**

**Note:** Since exact adjustment cannot be performed, remember the positions of the controls before performing the adjustment. If the positions after the primary adjustment are only a little different, return the controls to the original position.

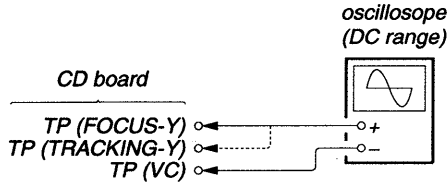

**Procedure:**

1. Keep the set horizontal.  
If the set is not horizontal, this adjustment cannot be performed due to the gravity against the 2-axis device.
2. Connect the oscilloscope TP (FOCUS-Y) and TP (VC) on the CD board.
3. Insert the disc (YEDS-18) in and close the lid for CD.
4. Put the set into test mode. (See page 22.)
5. Press the **▶||** button.  
[From focus searching, focus is turned ON while entering CLV drawing-in mode. Tracking and sled are turned OFF.]
6. Press the PLAY MODE button.  
[Both tracking and sled are turned ON.]
7. Adjust RV702 so that the waveform is as shown in the figure below. (Focus gain adjustment)

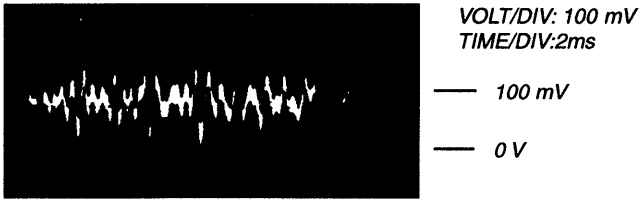

- Inconnect Examples (DC level changes more than on adjusted waveform)

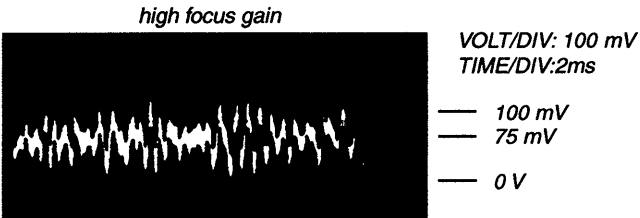
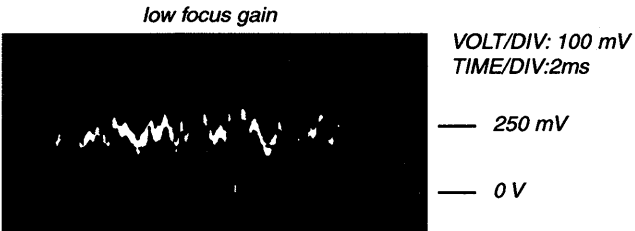

8. Connect the oscilloscope to TP (TRACKING-Y) and TP (VC) on the CD MAIN board.
9. Adjust RV704 so that the waveform is as shown in the figure below. (tracking gain adjustment)



- Incorrect Examples (fundamental wave appears)

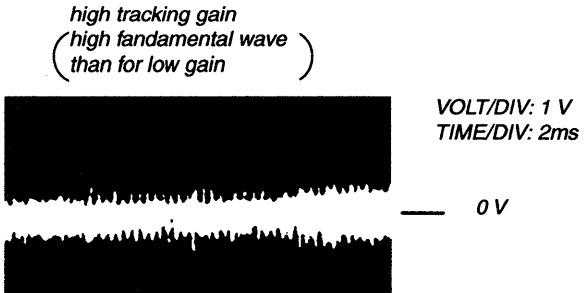
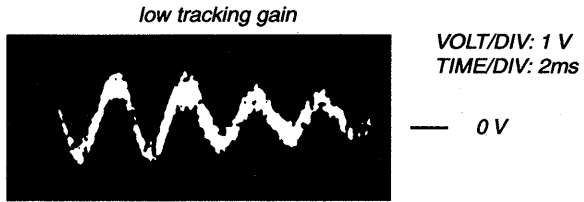

**Note:**  
VOLT/DIV: with the 10:1 probe in used.

10. Release test mode after adjustment is completed.

**Adjustment Location:** CD board (See page 23.)

**Connection and Adjustment Location:**

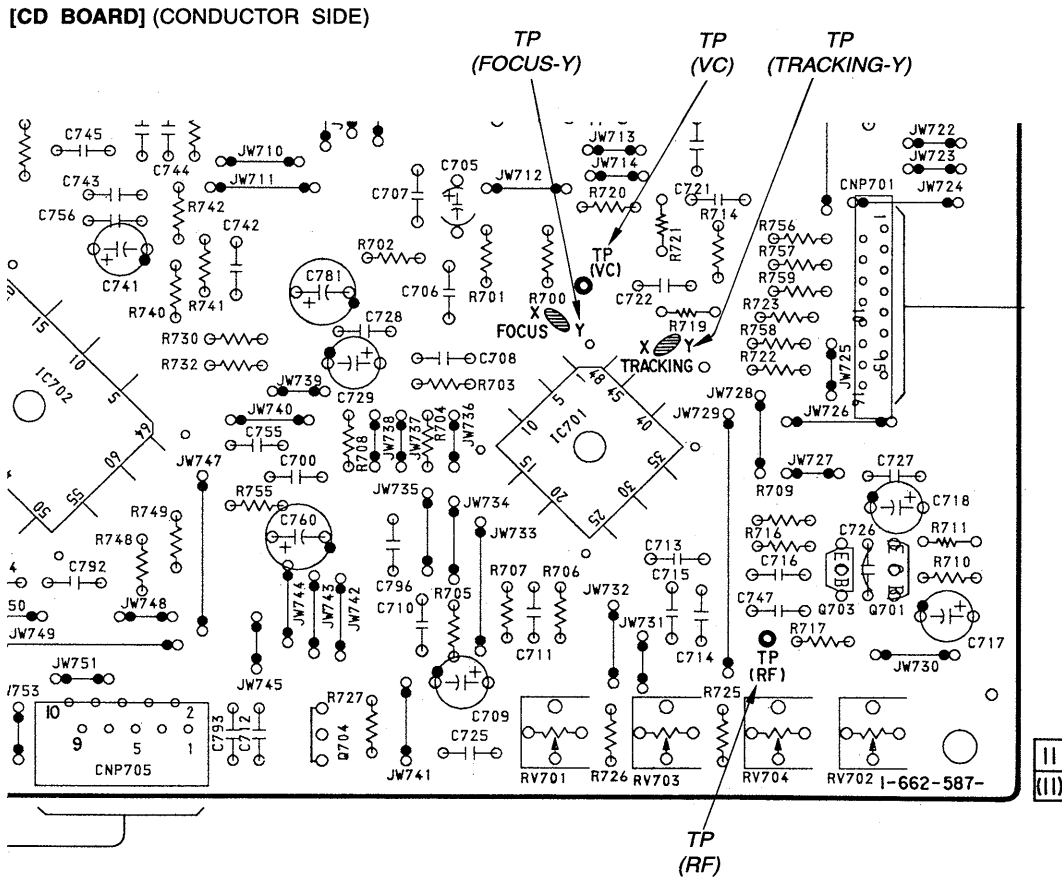

**[CD BOARD] (COMPONENT SIDE)**

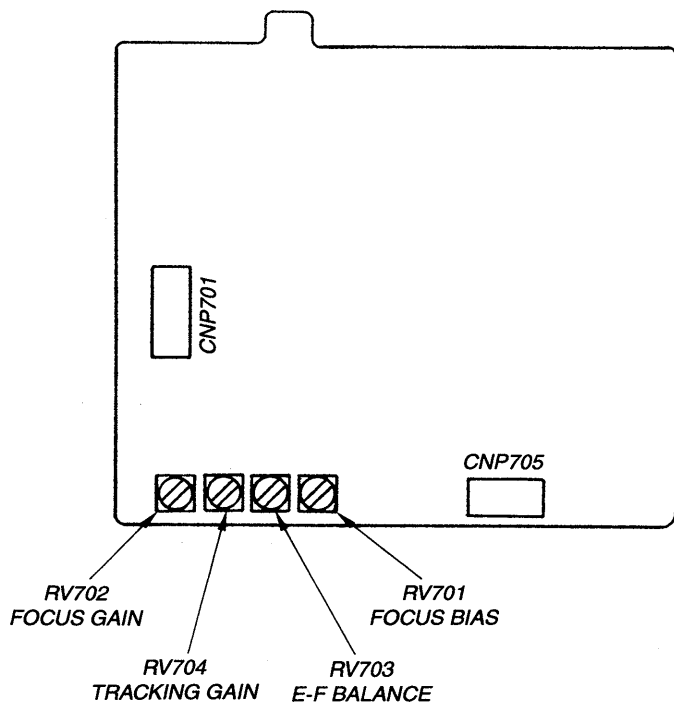

SECTION 5  
DIAGRAMS

5-1. BLOCK DIAGRAM - CD, SYSTEM CONTROL Section -

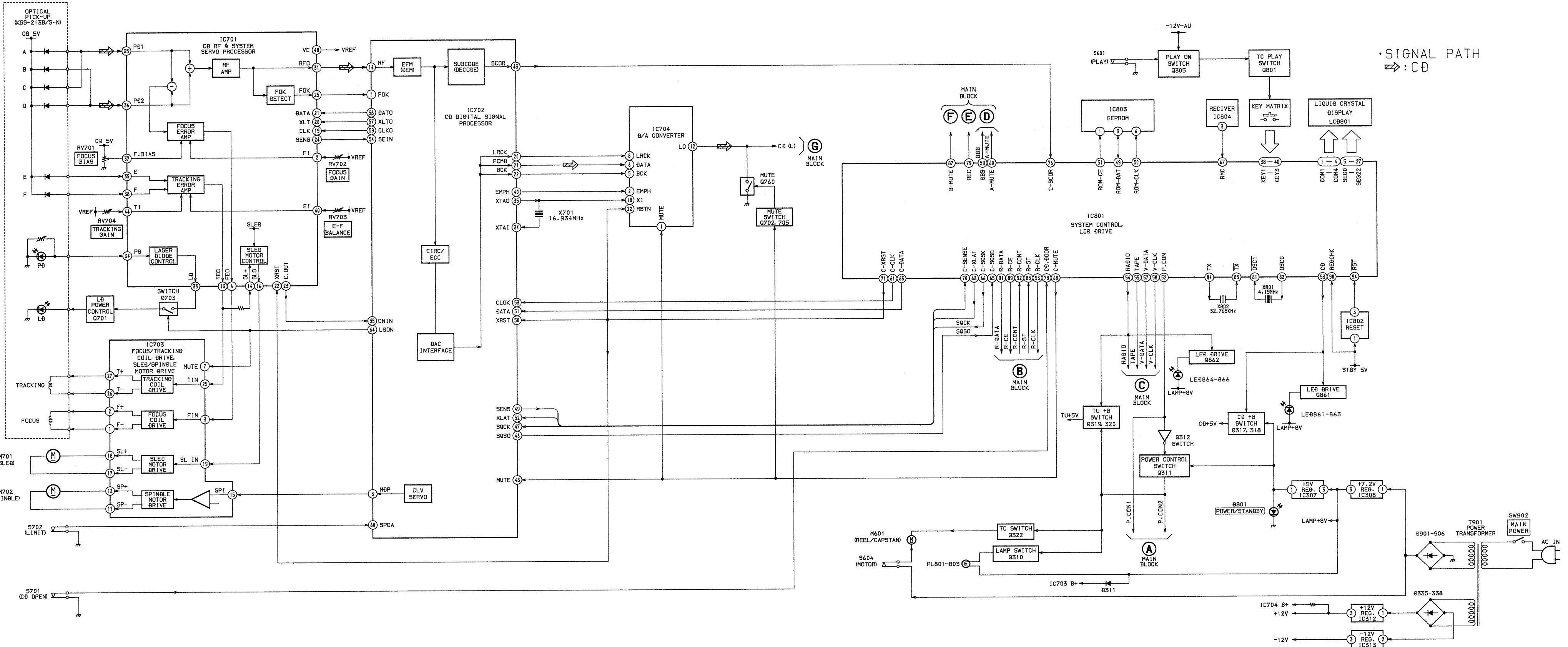

5-2. BLOCK DIAGRAM - MAIN Section -

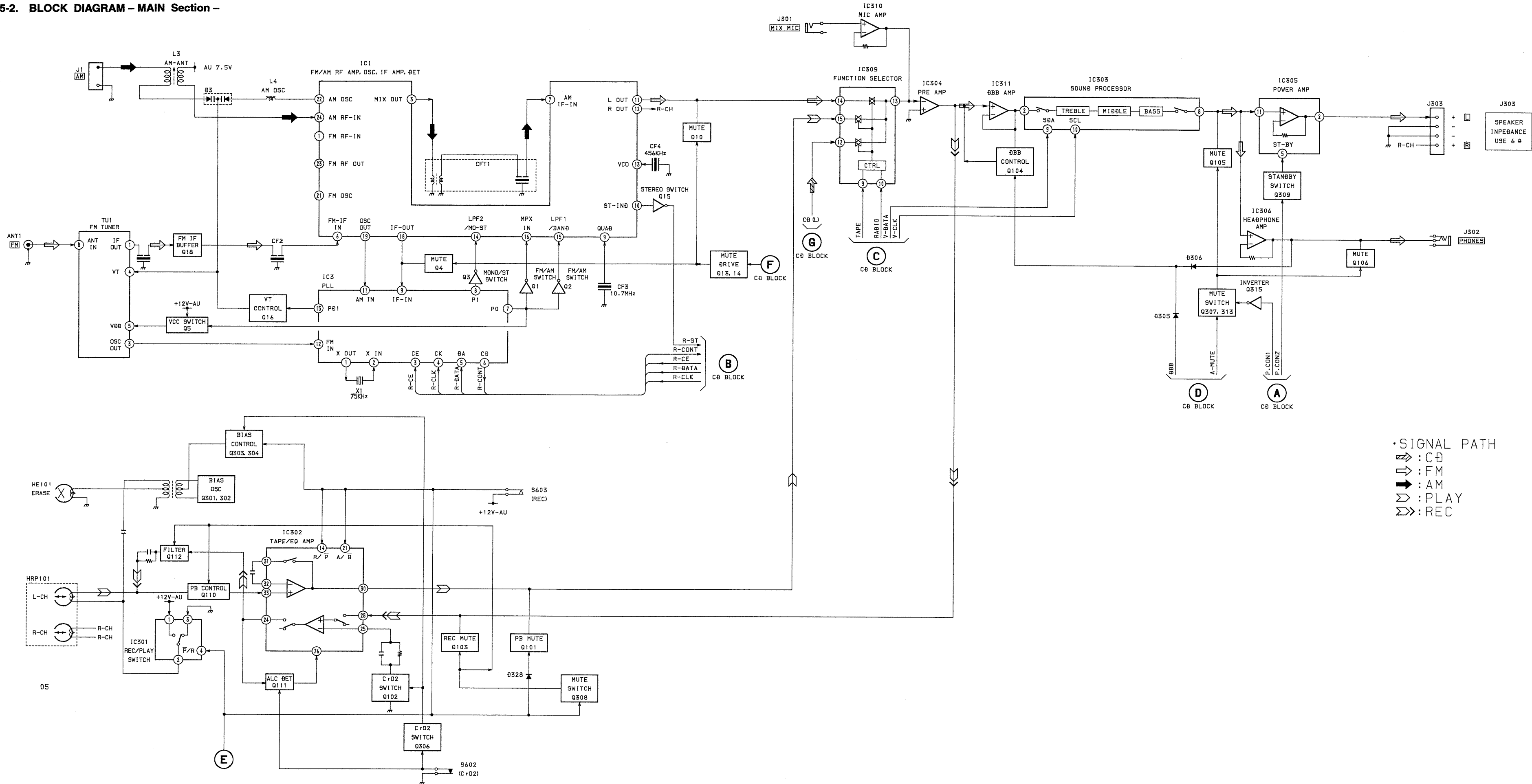

• SIGNAL PATH  
 ⇨ : CØ  
 ⇨ : FM  
 ⇨ : AM  
 ⇨ : PLAY  
 ⇨ : REC

\*R-CH: SAME AS L-CH.

5-3. PRINTED WIRING BOARDS - CD, SYSTEM CONTROL Section -

• Circuit Boards Location

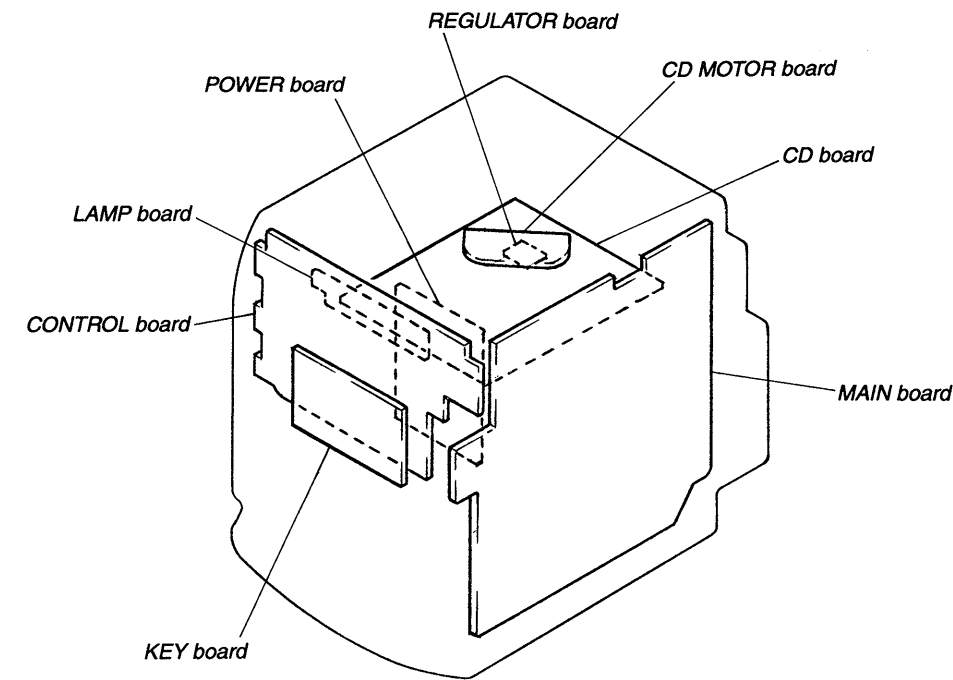

• Semiconductor Location

Ref. No.	Location
D702	D-9
D703	D-9
D801	B-6
D802	D-3
D861	E-4
D862	E-3
D863	E-4
D865	F-3
D866	F-4
IC701	F-11
IC702	F-9
IC703	D-12
IC704	D-9
IC801	C-4
IC802	C-2
IC803	C-5
IC804	B-6
Q701	G-13
Q702	D-9
Q703	G-12
Q705	D-10
Q760	E-10
Q770	D-10
Q801	C-1
Q861	G-5
Q862	G-5

Note on Printed Wiring Board:

- : parts extracted from the component side.
- △ : internal component.
- ▨ : Pattern from the side which enables seeing. (The other layers' patterns are not indicated.)

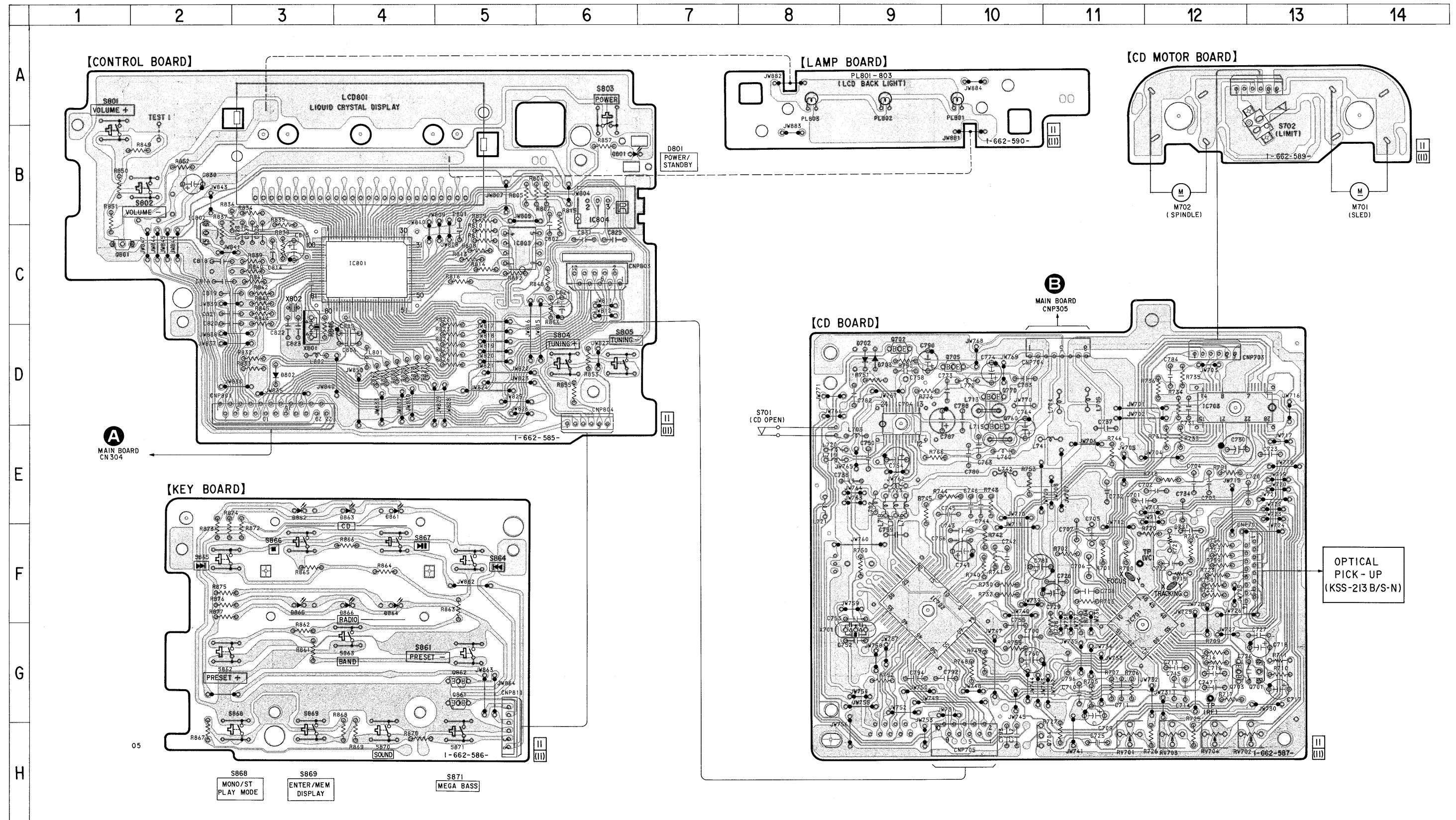

5-4. SCHEMATIC DIAGRAM - CD, SYSTEM CONTROL Section -  
• See page 46 for IC Block Diagrams.

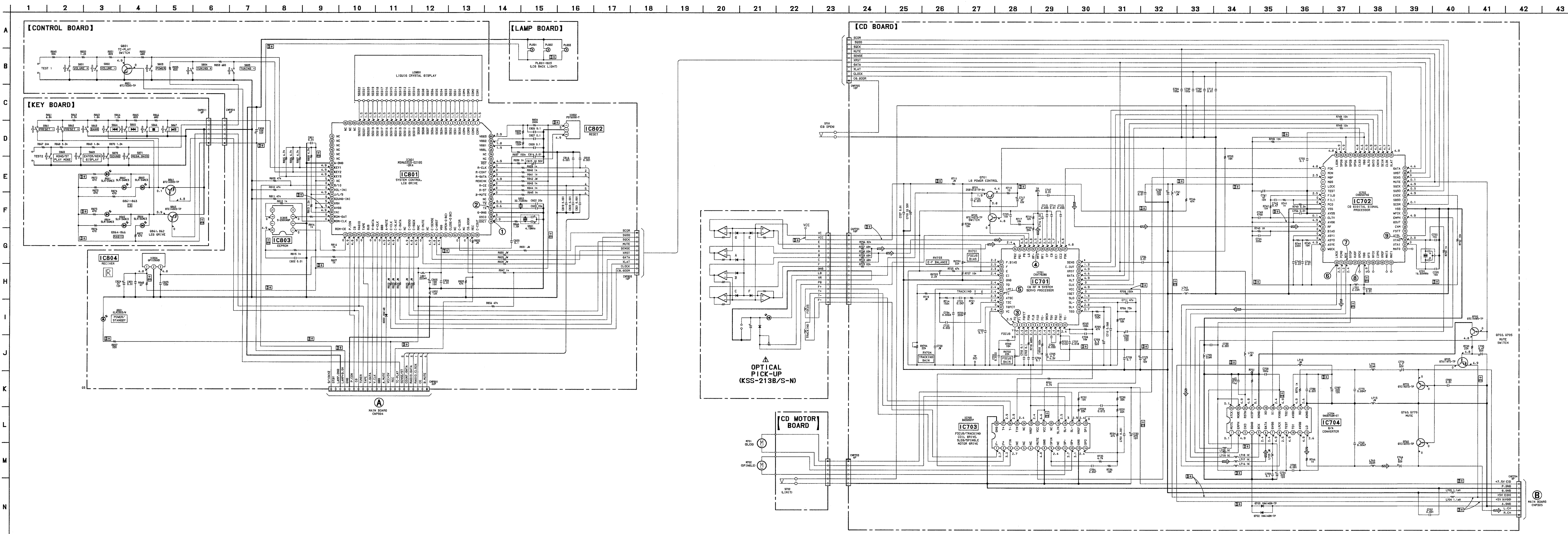

• Waveforms

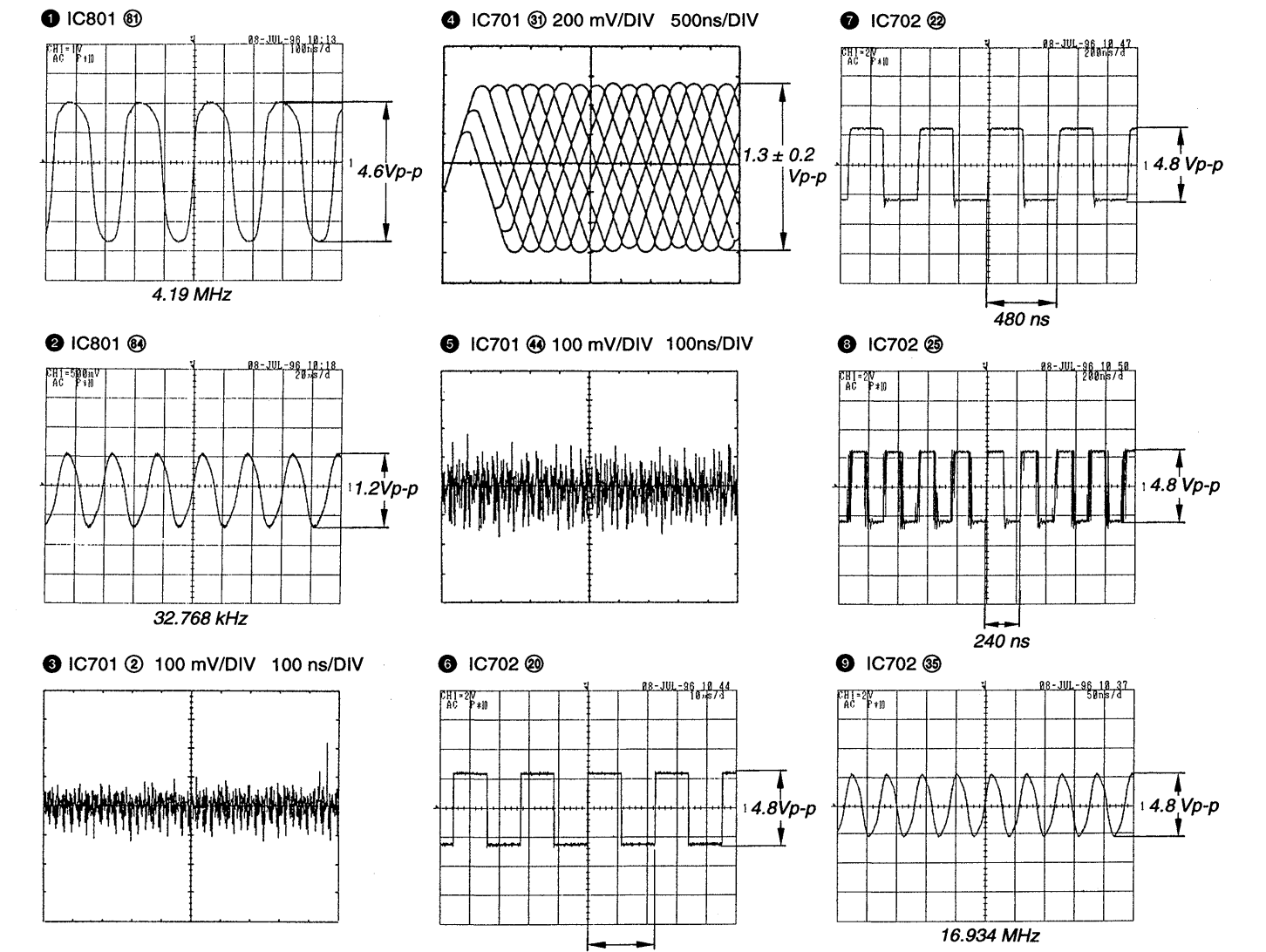

**Note on Schematic Diagram:**

- All capacitors are in  $\mu\text{F}$  unless otherwise noted. pF:  $\mu\text{pF}$  50 WV or less are not indicated except for electrolytics and tantalums.
- All resistors are in  $\Omega$  and  $\frac{1}{4}$  W or less unless otherwise specified.
- $\Delta$  : internal component.
- $\square$  : panel designation.

**Note:** The components identified by mark  $\Delta$  or dotted line with mark  $\Delta$  are critical for safety. Replace only with part number specified.

- $\square +$  : B+ Line.
- $\square$  : adjustment for repair.
- Voltages and waveforms are dc with respect to ground under no-signal CD conditions. no mark : CD
- \* : Impossible to measure
- Voltages are taken with a VOM (input impedance 10 M $\Omega$ ). Voltage variations may be noted due to normal production tolerances.
- Waveforms are taken with an oscilloscope. Voltage variations may be noted due to normal production tolerances.
- Circled numbers refer to waveforms.
- Signal path.
- $\Rightarrow$  : CD

5-5. SCHEMATIC DIAGRAM - MAIN Section -  
• See page 46 for IC Block Diagrams.

• Waveforms

① IC1

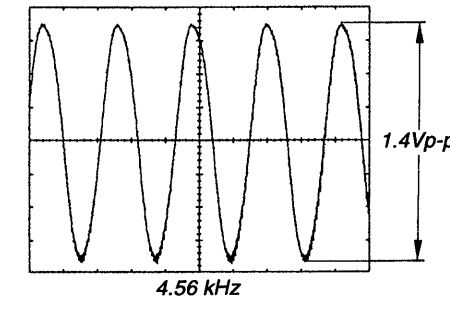

② IC3

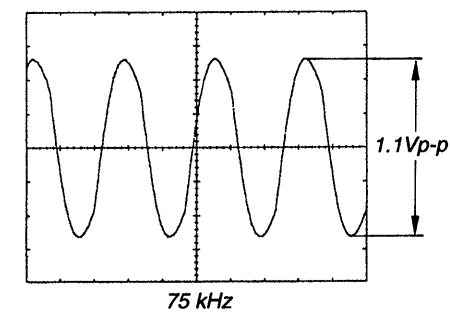

Note on Schematic Diagram:

- All capacitors are in  $\mu\text{F}$  unless otherwise noted. pF:  $\mu\text{F}$  50 WV or less are not indicated except for electrolytics and tantalums.
  - All resistors are in  $\Omega$  and  $\frac{1}{4} W$  or less unless otherwise specified.
  - $\Delta$  : internal component.
  - $\square$  : panel designation.
- Note: The components identified by mark  $\Delta$  or dotted line with mark  $\Delta$  are critical for safety. Replace only with part number specified.

- $\text{B}+$  : B + Line.
- $\text{B}-$  : B - Line.
- $\square$  : adjustment for repair.
- AC voltage readings in the bias oscillator with a VTVM.
- Total current is measured with no cassette installed.
- Power voltage is dc V and fed with regulated dc power supply from external power voltage jack.
- Voltages and waveforms are dc with respect to ground under no-signal (detuned) conditions.
- no mark : FM
- ( ) : AM
- << >> : REC
- [ ] : PB
- Voltages are taken with a VOM (input impedance 10 M $\Omega$ ). Voltage variations may be noted due to normal production tolerances.
- Waveforms are taken with an oscilloscope. Voltage variations may be noted due to normal production tolerances.
- Circled numbers refer to waveforms.
- Signal path.
- $\rightarrow$  : FM
- $\rightarrow$  : AM
- $\rightarrow$  : PB
- $\rightarrow$  : REC
- $\rightarrow$  : CD

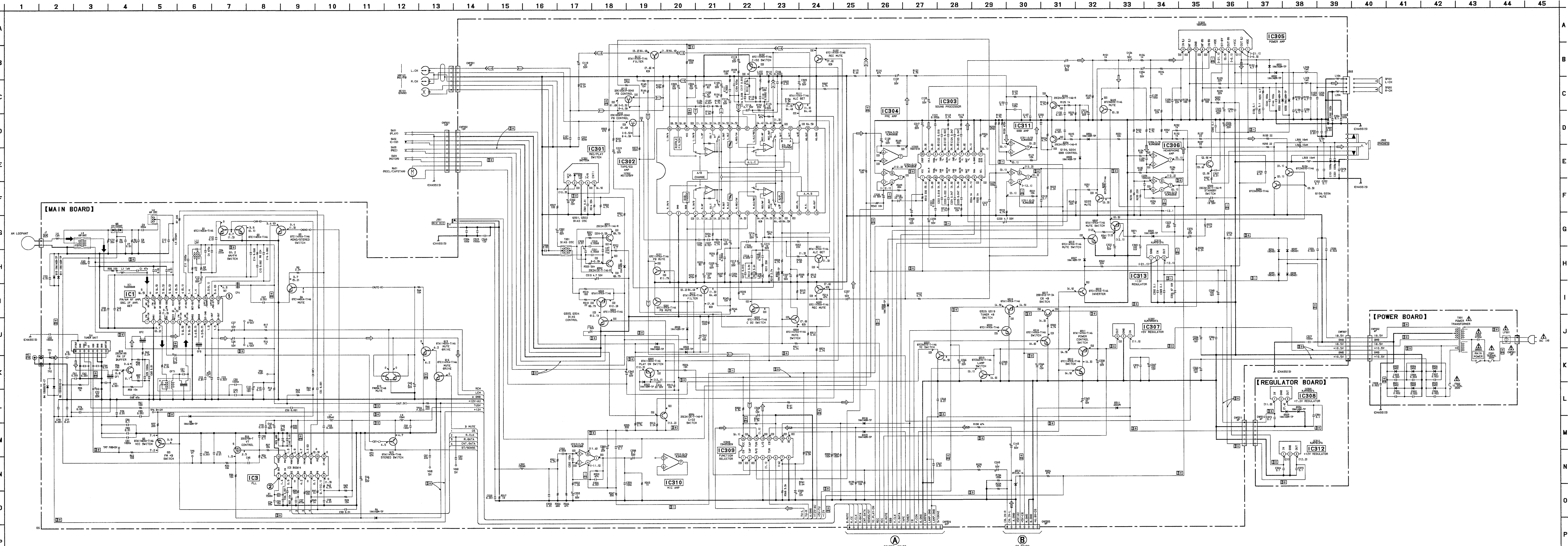

5-6. PRINTED WIRING BOARDS - MAIN Section -  
 • See page 30 for Circuit Boards Location.

• Semiconductor Location

Ref. No.	Location	Ref. No.	Location
D3	D-7	IC311	F-9
D4	A-9	IC312	H-13
D5	A-9	IC313	G-8
D6	E-9		
D8	D-10	Q1	D-8
D10	B-7	Q2	D-9
D11	B-7	Q3	D-9
D301	G-3	Q4	D-9
D302	H-7	Q5	C-11
D303	H-5	Q10	D-9
D304	H-4	Q13	D-10
D305	D-6	Q14	D-9
D306	B-6	Q15	D-10
D308	E-10	Q16	B-10
D309	F-9	Q18	B-8
D310	F-9	Q101	F-5
D311	E-4	Q102	F-6
D318	E-4	Q103	F-6
D319	E-4	Q104	F-9
D323	H-4	Q105	F-10
D327	E-10	Q106	B-5
D328	H-5	Q110	F-4
D329	H-13	Q111	F-6
D330	D-10	Q112	F-5
D331	D-10	Q201	H-5
D332	D-11	Q202	H-7
D333	D-11	Q203	H-6
D334	H-13	Q204	G-8
D335	H-9	Q205	F-10
D336	H-9	Q206	C-5
D337	G-9	Q210	G-5
D338	G-9	Q211	G-6
D901	F-17	Q212	G-5
D902	F-17	Q301	G-4
D903	F-16	Q302	G-4
D904	F-17	Q303	G-3
D905	G-17	Q304	H-3
D906	G-17	Q306	H-5
		Q307	F-10
IC1	C-8	Q308	G-6
IC3	C-10	Q309	G-10
IC301	G-4	Q310	H-7
IC302	G-6	Q311	D-3
IC303	F-8	Q312	D-3
IC304	E-6	Q313	F-10
IC305	F-11	Q315	E-10
IC306	C-5	Q317	D-4
IC307	H-7	Q318	D-4
IC308	I-13	Q319	C-5
IC309	E-5	Q320	C-6
IC310	B-4	Q322	H-7

**Note on Printed Wiring Board:**  
 • — : parts extracted from the component side.  
 • Δ : internal component.  
 • [Pattern] : Pattern from the side which enables seeing.  
 (The other layers' patterns are not indicated.)

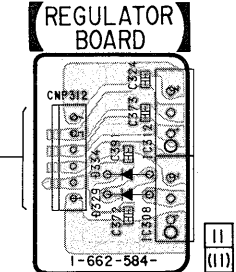
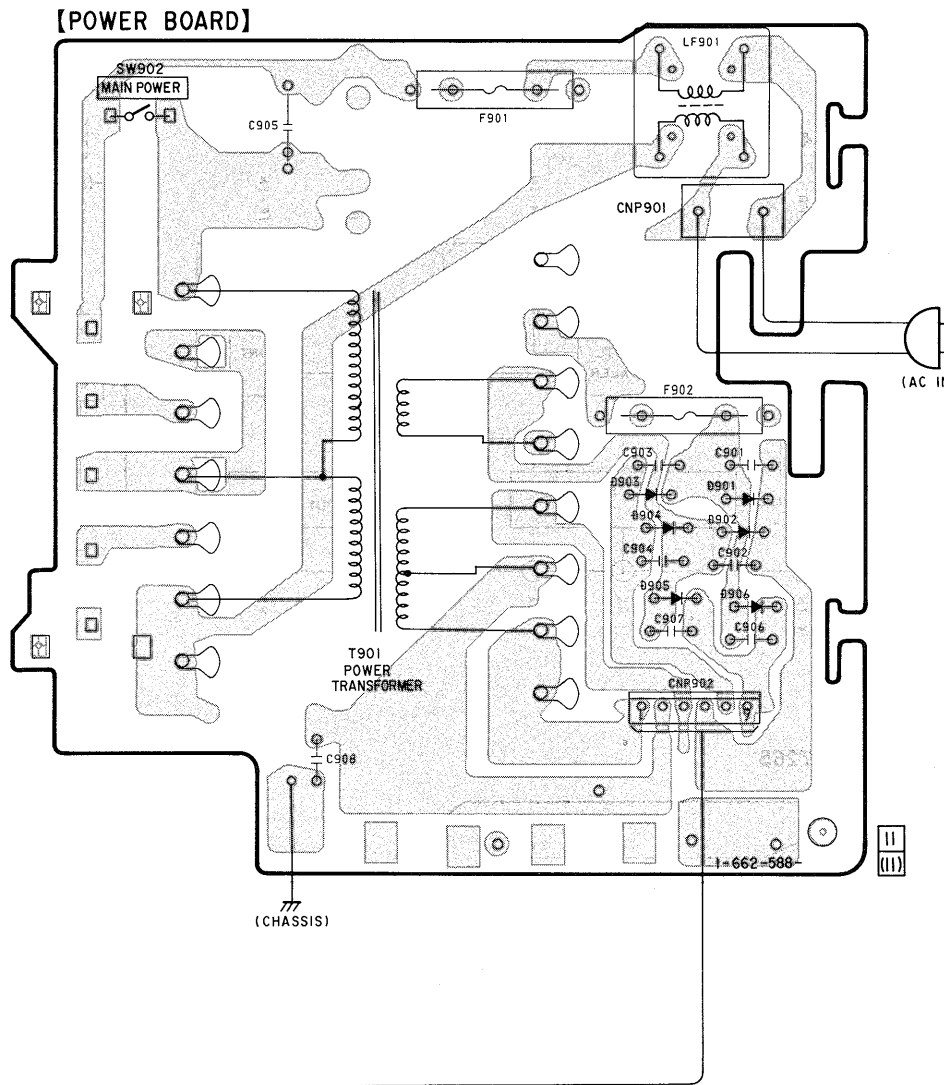
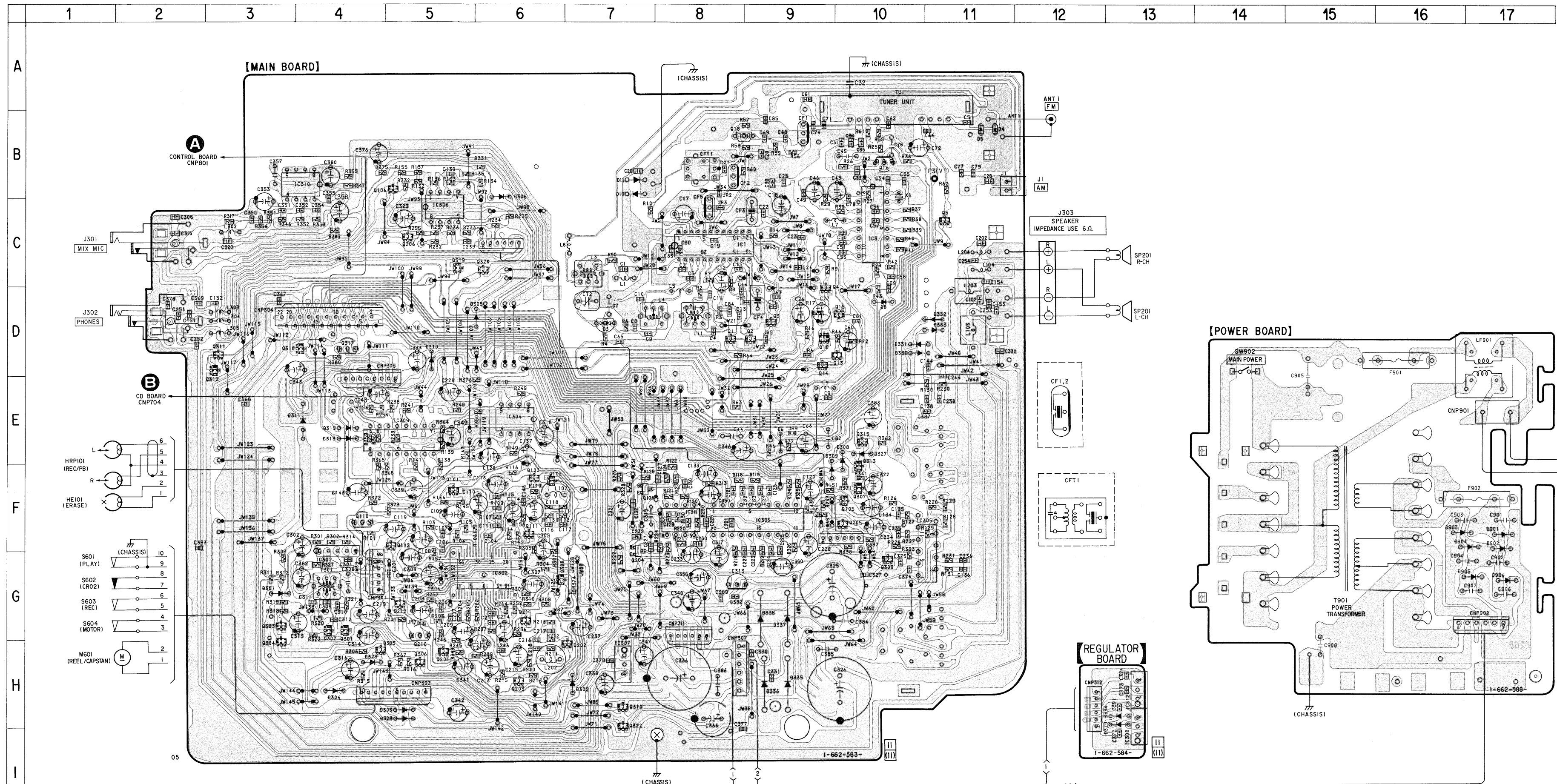

• IC Block Diagram

IC1 TA2008AN

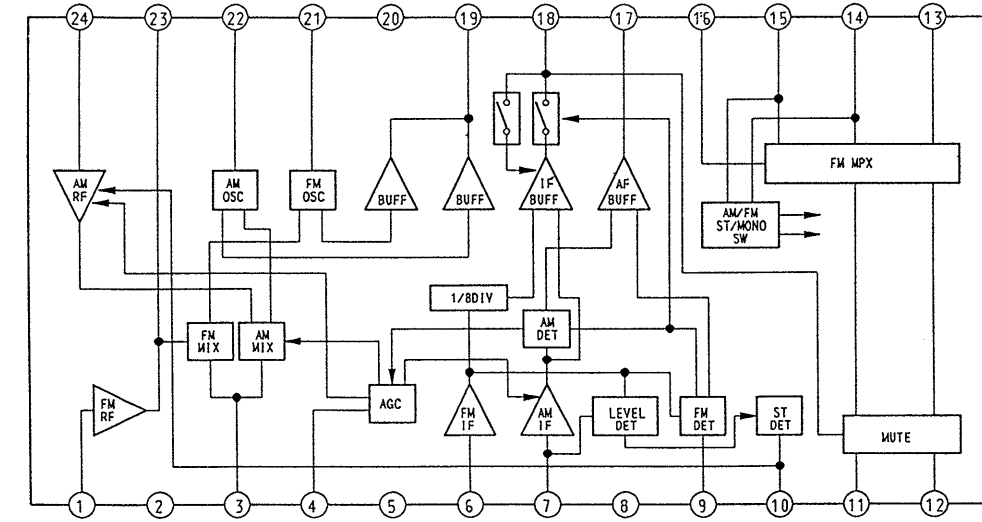

IC3 BU2614

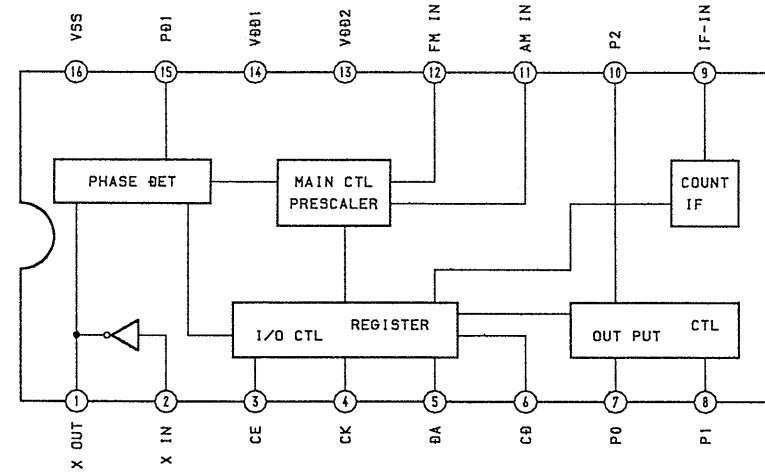

IC305 TDA7265

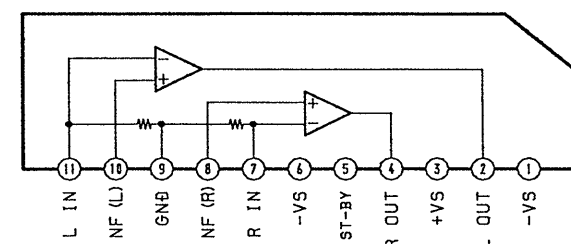

IC303 TDA7319

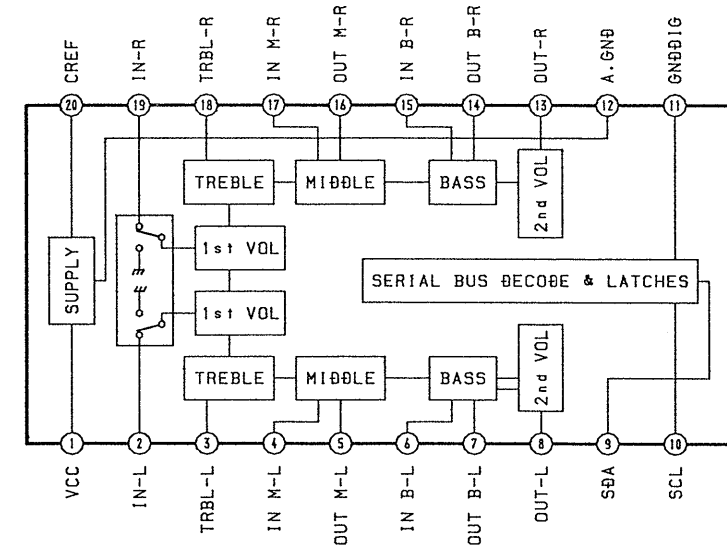

IC309 CD4052BCN

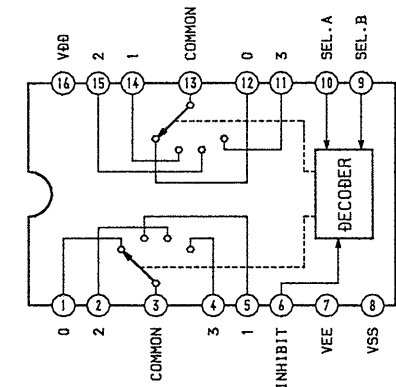

IC701 CXA1782BQ

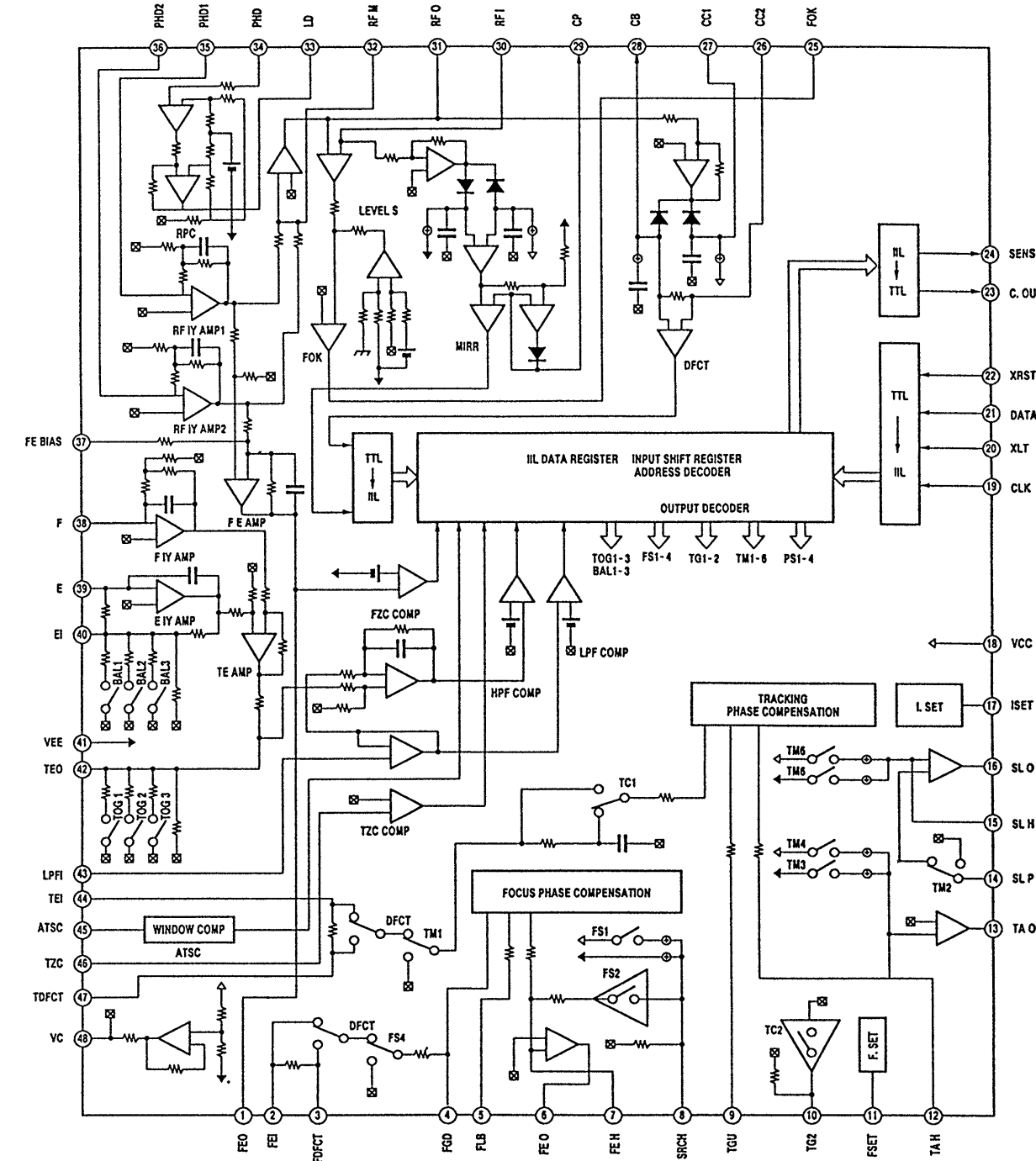

IC702 CXD2507AQ

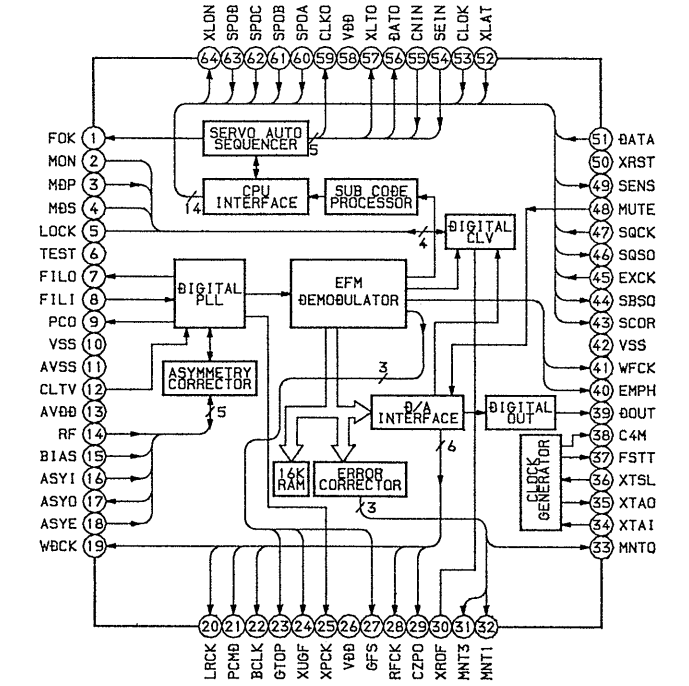

IC703 BA5930FP

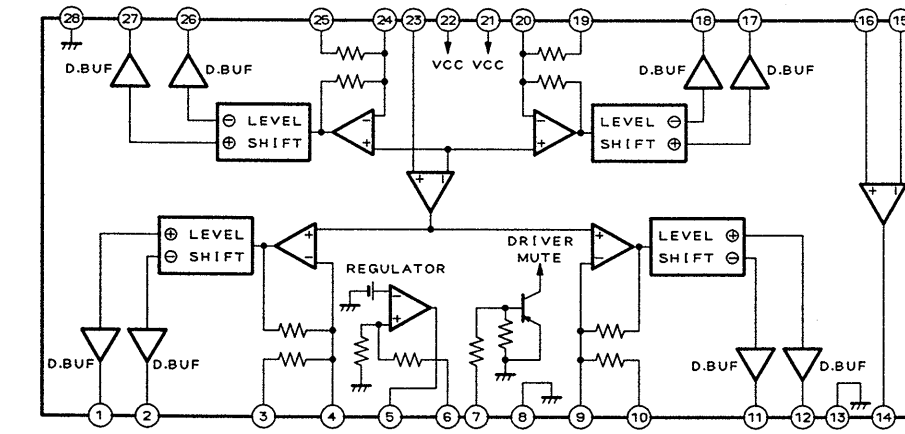

IC704 SM5875AM-ET

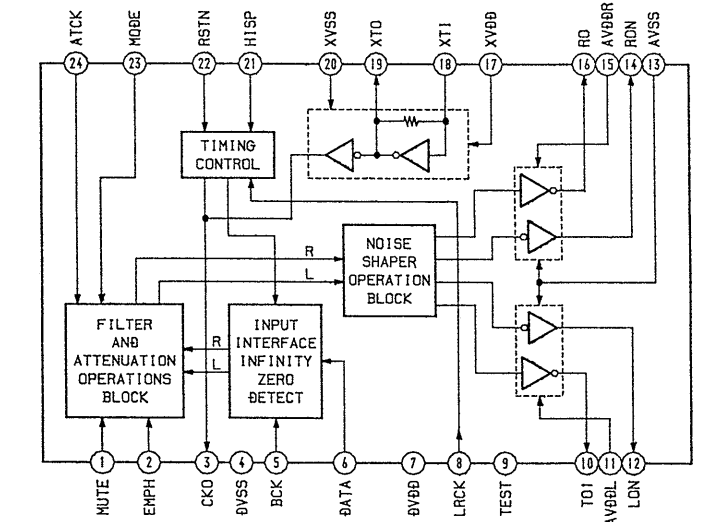

### 5-7. IC PIN FUNCTION DESCRIPTION

#### CONTROL BOARD IC801 MSM65353-021GS-BK4 (SYSTEM CONTROL, LCD DRIVE)

Pin No.	Pin Name	I/O	Function
1	COM1	O	LCD common output.
2	COM2	O	
3	COM3	O	
4	COM4	O	
5	SEG0	O	LCD Segment output
6	SEG1	O	
7	SEG2	O	
8	SEG3	O	
9	SEG4	O	
10	SEG5	O	
11	SEG6	O	
12	SEG7	O	
13	SEG8	O	
14	SEG9	O	
15	SEG10	O	
16	SEG11	O	
17	SEG12	O	
18	SEG13	O	
19	SEG14	O	
20	SEG15	O	
21	SEG16	O	
22	SEG17	O	
23	SEG18	O	
24	SEG19	O	
25	SEG20	O	
26	SEG21	O	
27	SEG22	O	
28	NC	-	Not used (OPEN)
29	NC	-	
30	NC	-	
31	NC	-	
32	NC	-	
33	NC	-	
34	NC	-	
35	NC	-	
36	NC	-	
37	A-GND	-	Analog ground
38	KEY1	I	Key input
39	KEY2	I	
40	KEY3	I	

Pin No.	Pin Name	I/O	Function
41	NC	–	Not used. (Fixed at “H”)
42	9/10	I	9k/10k select input. (not used)
43	VOL-INI	I	Volume initial setting input. (Fixed at “L”)
44	J/L/S	I	Volume initial setting input.
45	SOUND-INI	I	Volume initial setting. (Fixed at “L”)
46	VRH	–	AD reference voltage input.
47	AVDD	–	Analog power supply. (+5 V)
48	INI	O	Initial setting output.
49	ROM-DATA	I/O	EEPROM (IC803) data input/output.
50	ROM-CLK	O	EEPROM (IC803) clock output.
51	ROM-CE	O	EEPROM (IC803) chip enable output.
52	P-CON	O	Power ON/OFF control output.
53	CD	O	Function CD output.
54	RADIO	O	Function CD output.
55	TAPE	O	Function tape output.
56	DUB	–	Not used. (OPEN)
57	V-DATA	O	Volume data output.
58	V-CLK	O	Volume clock output.
59	DBB	O	DBB ON/OFF output.
60	A-MUTE	O	Audio mute output.
61	C-CLK	O	Clock output.for CD DSP (IC702) command.
62	C-XLAT	O	CD DSP (IC702) command.
63	C-DATA	O	CD DSP (IC702) command data output.
64	NC	–	Not used. (OPEN)
65	C-SQSO	I	CD SUBQ input.
66	C-SQCK	O	Clock output for CD SUBQ.
67	RMC	I	Remote commander input.
68	C-MUTE	O	CD mute output.
69	NC	–	Not used. (OPEN)
70	C-SENS	I	CD-SENS input.
71	C-XRST	O	CD System reset output.
72	VDD	–	Digital power supply. (+ 5 V)
73	NC	–	Not used. (OPEN)
74	NC	–	
75	NC	–	
76	C-SCOR	I	CD-SCOR input.
78	NC	–	Not used.
79	REC	I	REC input.
80	C-COUNT	–	Not used. (OPEN)

Pin No.	Pin Name	I/O	Function
81	$\overline{\text{OSC1}}$	O	Main clock output.(4.19 MHz)
82	OSC0	I	Main clock input. (4.19 MHz)
83	D-GND	-	Digital ground.
84	TX	I	SUB clock input. (32.768 kHz)
85	$\overline{\text{TX}}$	O	SUB clock output. (32.768 kHz)
86	NC	-	Not used. (OPEN)
87	R-MUTE	O	Mute for tuner.
88	R-ST	I	R-STEREO input.
89	R-CE	O	Tuner PLL IC CE output.
90	REGCHK	I	Regulator check input.
91	R-DATA	O	Tuner PLL IC data output.
92	R-COUNT	I	Tuner PLL IC count output.
93	R-CLK	O	Tuner PLL IC clock output.
94	$\overline{\text{RST}}$	I	Reset input.
95	NC	-	Not used (OPEN)
96	NC	-	
97	VDDL	-	
98	VDD1	-	Bias power supply for LCD drive
99	VDD2	-	
100	VDD3	-	

## SECTION 6 EXPLODED VIEWS

**NOTE:**

- -XX and -X mean standardized parts, so they may have some difference from the original one.
- Color Indication of Appearance Parts Example:  
KNOB, BALANCE (WHITE) . . . (RED)

↑
↑  
 Parts Color    Cabinet's Color

- Items marked "\*" are not stocked since they are seldom required for routine service. Some delay should be anticipated when ordering these items.
- The mechanical parts with no reference number in the exploded views are not supplied.
- Hardware (# mark) list and accessories and packing materials are given in the last of the electrical parts list.

The components identified by mark  $\Delta$  or dotted line with mark  $\Delta$  are critical for safety. Replace only with part number specified.

**(1) CHASSIS SECTION**

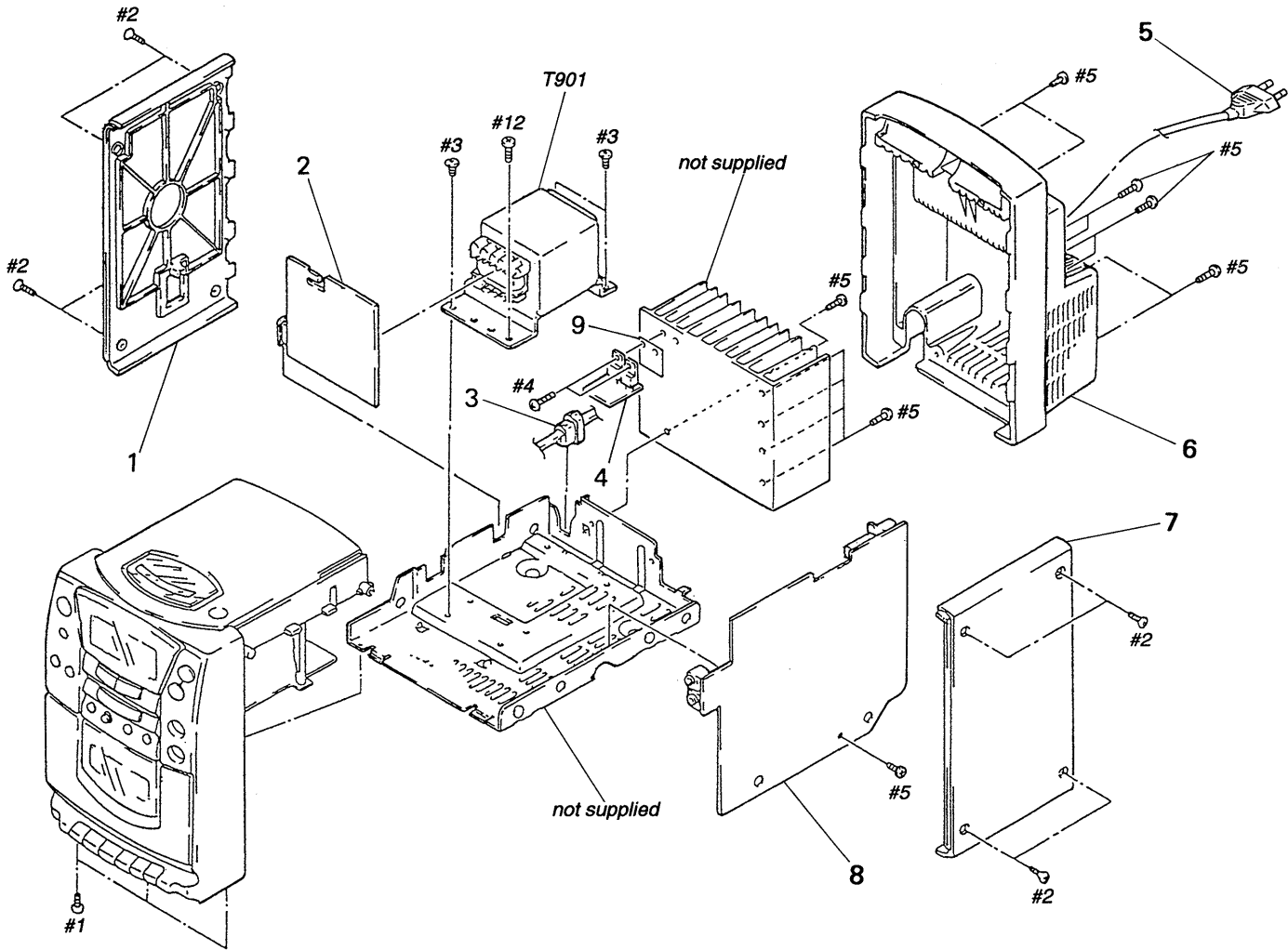

Ref. No.	Part No.	Description	Remark	Ref. No.	Part No.	Description	Remark
1	3-928-398-01	PANEL (L), SIDE		6	3-938-872-01	CABINET (REAR)	
* 2	1-662-588-11	POWER BOARD		7	3-928-399-01	PANEL (R), SIDE	
* 3	3-703-244-00	BUSHING (2104), CORD		* 8	A-3293-236-A	MAIN BOARD, COMPLETE	
* 4	1-662-584-11	REGULATOR BOARD		* 9	3-939-536-01	SHIELD, IC	
$\Delta$ 5	1-575-651-21	CORD, POWER		$\Delta$ T901	1-429-859-11	TRANSFORMER, POWER	

## (2) FRONT CABINET SECTION

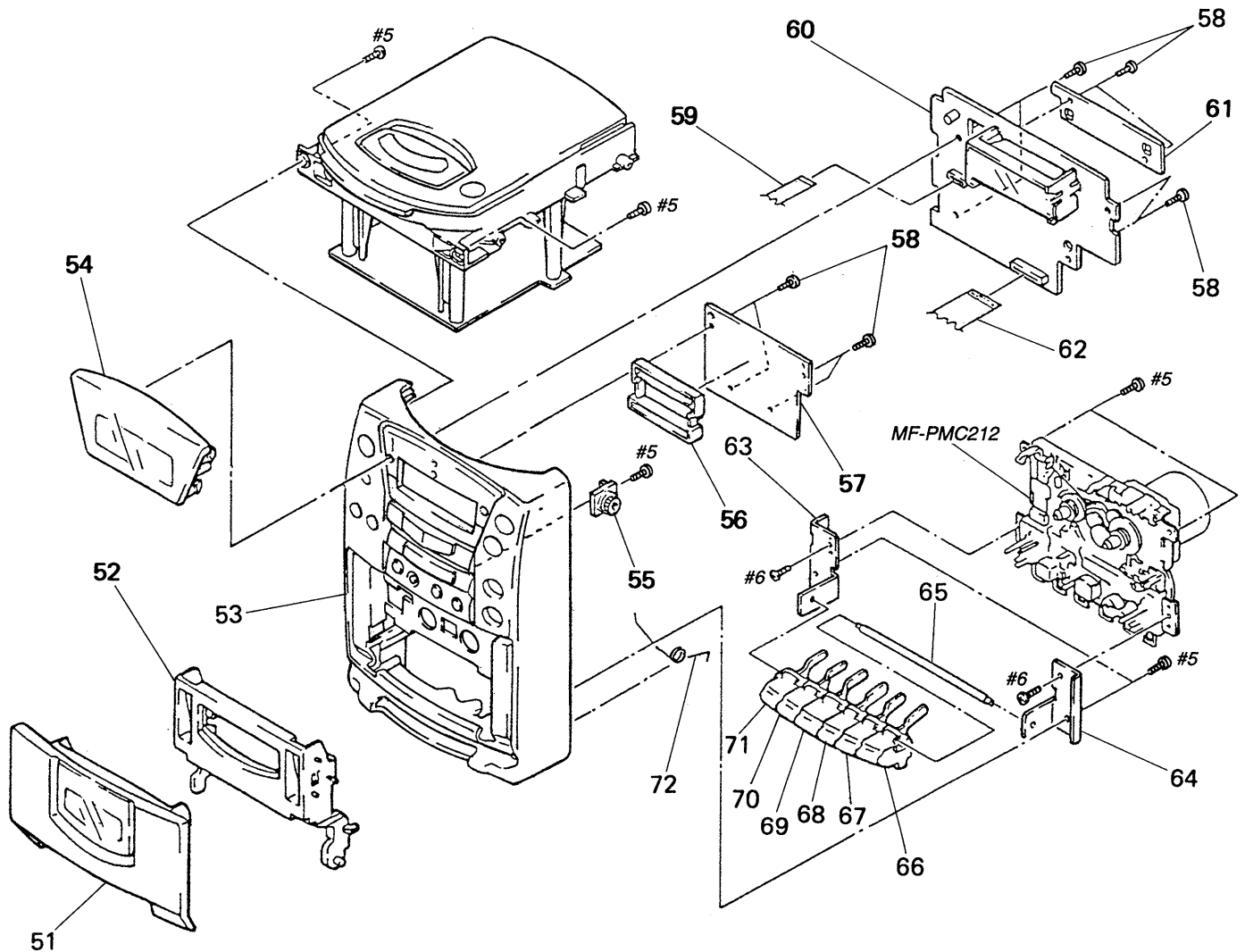

Ref. No.	Part No.	Description	Remark
51	X-3372-676-1	DOOR ASSY, CASSETTE	
52	3-928-355-01	HOLDER, CASSETTE	
53	X-3370-929-1	CABINET SUB ASSY, FRONT	
54	3-928-367-01	WINDOW, LCD	
55	3-351-377-01	DAMPER	
56	3-928-369-01	CASE, LED	
* 57	A-3306-097-A	KEY BOARD, COMPLETE	
58	4-951-620-01	SCREW (2. 6X8), +BVTP	
59	1-775-835-11	WIRE, PARALLEL (FFC) (10 CORE)	
* 60	A-3306-098-A	CONTROL BOARD, COMPLETE	
* 61	1-662-590-11	LAMP BOARD	

Ref. No.	Part No.	Description	Remark
62	1-775-834-11	WIRE, PARALLEL (FFC) (22 CORE)	
63	3-928-358-01	SHAFT (L), BEARING	
64	3-928-359-01	SHAFT (R), BEARING	
65	3-928-360-01	SHAFT, MD	
66	3-928-366-01	BUTTON, PAUSE (  )	
67	3-928-365-01	BUTTON, STOP (■/▲)	
68	3-928-364-01	BUTTON, FF (▶▶)	
69	3-928-363-01	BUTTON, REW (◀◀)	
70	3-928-362-01	BUTTON, PLAY (▶)	
71	3-928-361-01	BUTTON, REC (●)	
72	3-928-357-01	SPRING, CASSETTE	

**(3) CD BLOCK SECTION**

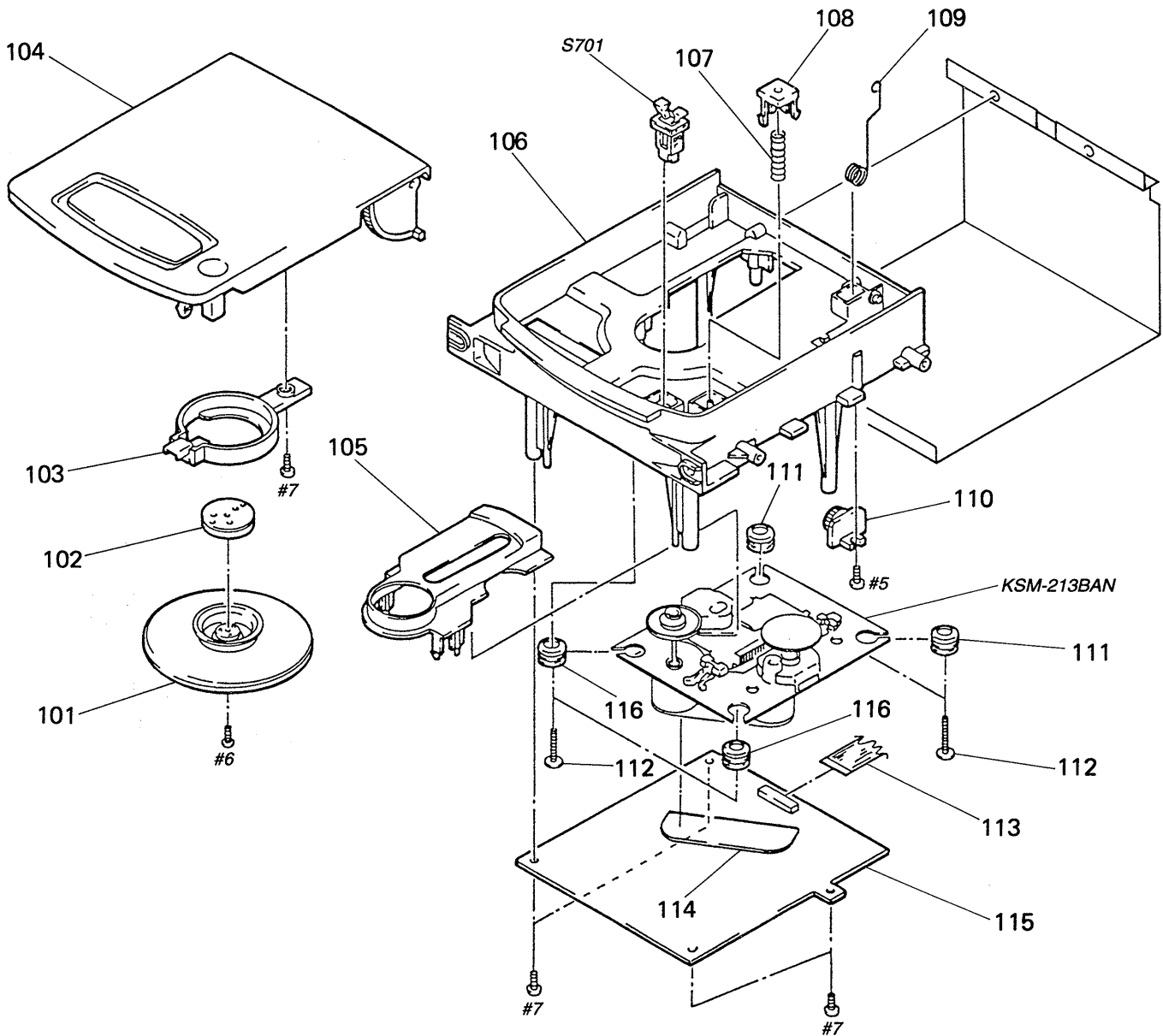

Ref. No.	Part No.	Description	Remark	Ref. No.	Part No.	Description	Remark
101	3-920-158-01	PLATE, CHUCKING		110	3-351-377-01	DAMPER	
102	1-452-732-11	MAGNET		111	3-910-095-11	RUBBER, VIBRATION PROOF (RED)	
103	3-923-733-01	HOLDER (CHUCK)		112	3-916-006-01	SCREW (2. 6X16)	
104	X-3370-927-1	DOOR SUB ASSY, CD		113	1-769-824-11	WIRE (FLAT TYPE) (16 CORE)	
105	3-923-736-01	COVER, CD		* 114	1-662-589-11	CD MOTOR BOARD	
106	3-928-388-01	CHASSIS, CD		* 115	A-3306-101-A	CD BOARD, COMPLETE	
107	3-932-787-01	SPRING, CD LIFT		116	3-910-095-01	RUBBER, VIBRATION PROOF (GREEN)	
108	3-928-389-01	SLIDER, CD		S701	1-692-960-11	SWITCH, PUSH (1 KEY) (CD DOOR OPEN/CLOSE)	
109	3-928-387-01	SPRING, CD DOOR					

**(4) MECHANISM DECK SECTION-1  
(MF-PMC212)**

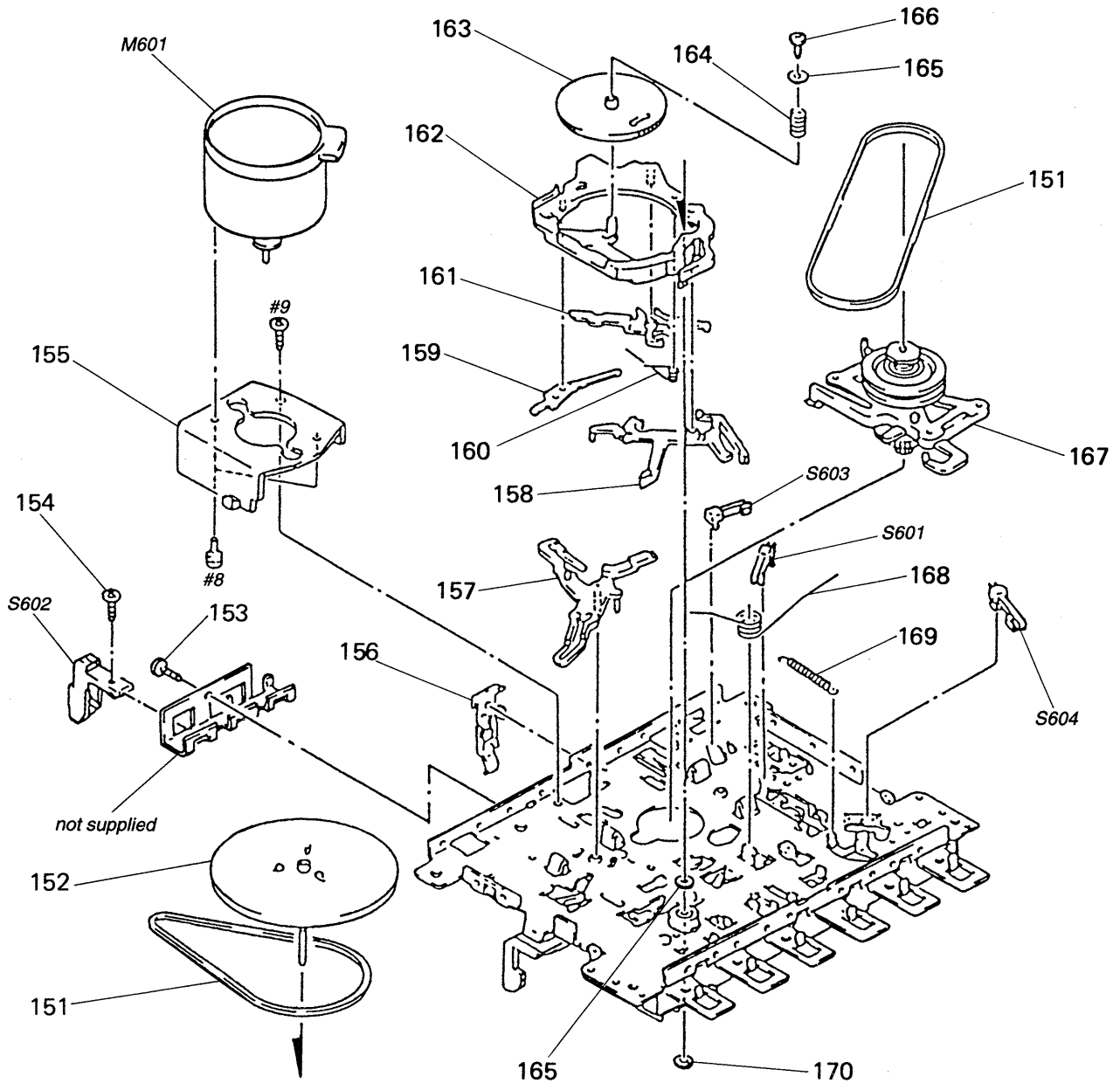

Ref. No.	Part No.	Description	Remark	Ref. No.	Part No.	Description	Remark
151	3-907-721-01	BELT		164	3-369-962-01	SPRING, COMPRESSION	
152	3-910-473-01	FW ASSY		165	3-369-961-01	WASHER	
153	3-929-030-01	SCREW		166	3-366-352-01	SCREW	
154	3-929-033-01	SCREW		167	3-362-969-01	IDLER ASSY, PF	
* 155	3-362-988-01	HOLDER, MOTOR		168	3-362-970-01	SPRING	
156	3-929-025-01	SPRING, CASSETTE		169	3-362-971-01	SPRING	
157	3-387-697-01	SENSOR		170	3-362-980-01	WASHER	
158	3-362-975-01	LEVER, SENSOR		M601	X-3372-674-1	MOTOR ASSY (REEL/CAPSTAN)	
159	3-362-978-01	SPRING, PLATE		S601	1-571-556-11	SWITCH, LEAF (PLAY)	
160	3-362-977-01	SPRING		S602	1-692-302-11	SWITCH, LEAF (0r02)	
161	3-362-976-01	LEVER, CONTROL		S603	1-571-556-11	SWITCH, LEAF (REC)	
162	3-362-973-01	AS (BASE)		S604	1-571-556-11	SWITCH, LEAF (MOTOR)	
163	X-3363-315-1	GEAR, CAM					

**(5) MECHANISM DECK SECTION-2  
(MF-PMC212)**

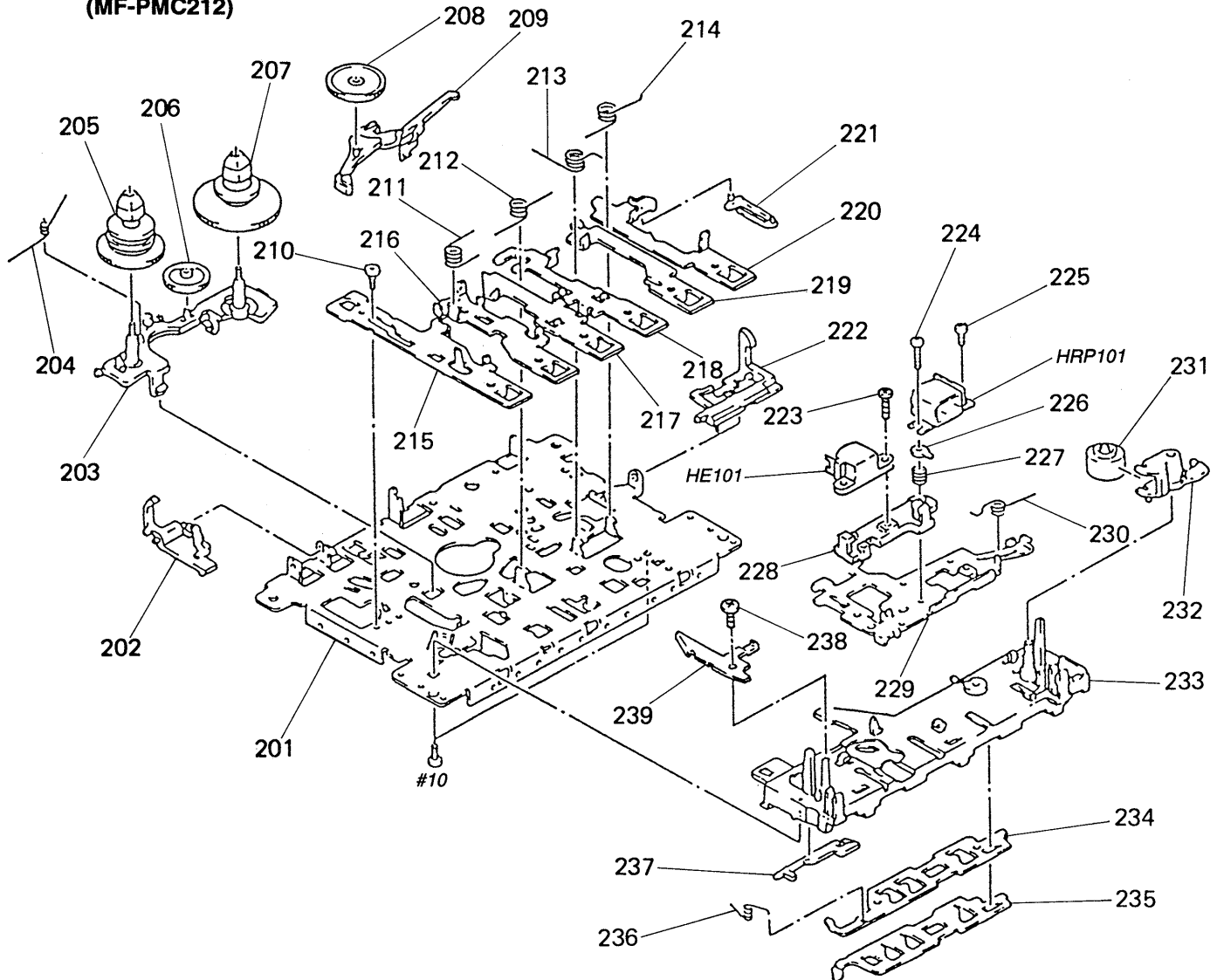

Ref. No.	Part No.	Description	Remark	Ref. No.	Part No.	Description	Remark
* 201	3-362-941-01	CHASSIS		222	3-362-968-01	LEVER, EJECT	
202	3-362-966-01	INTER LOCK		223	3-929-031-01	SCREW	
203	3-362-961-01	SPINDLE (BASE)		224	3-929-029-01	SCREW	
204	3-929-024-01	SPRING		225	3-929-030-01	SCREW	
205	X-3363-611-1	REEL, S		226	3-390-817-01	LUG	
206	3-362-965-01	IDLER, FF		227	3-929-027-01	SPRING	
207	3-362-962-01	REEL ASSY, T		* 228	3-929-028-01	HEAD, HOLDER	
208	3-362-960-01	PULLEY, IDLER		* 229	3-929-026-01	HEAD, BASE	
209	3-362-959-01	ARM, IDLER		230	3-362-983-01	SPRING	
210	3-362-958-01	SCREW		231	3-362-982-01	PINCH ROLLER	
211	3-362-954-01	SPRING		232	3-362-981-01	PINCH ARM	
212	3-362-955-01	SPRING		233	3-362-942-01	FRAME ASSY	
213	3-362-956-01	SPRING		* 234	3-362-943-01	PLATE, FUNCTION	
214	3-362-957-01	SPRING		* 235	3-362-946-01	LEVER, SW	
* 215	3-362-947-01	LEVER, REC		236	3-362-945-01	SPRING	
* 216	3-362-948-01	LEVER, PLAY		237	3-362-944-01	STOPPER, REC	
* 217	3-362-949-01	LEVER, REW		238	3-929-032-01	SCREW	
* 218	3-362-950-01	LEVER, FF		239	3-918-739-01	PLATE, SWITCH	
* 219	3-362-951-01	LEVER, SE		HE101	1-543-673-11	HEAD, MAGNETIC (ERASE)	
* 220	3-362-952-01	LEVER, PAUSE		HRP101	1-543-424-21	HEAD (RECORD/PLAYBACK)	
221	3-362-953-01	ARM, PAUSE					

**(6) OPTICAL PICK-UP SECTION  
(KSM-213BAN)**

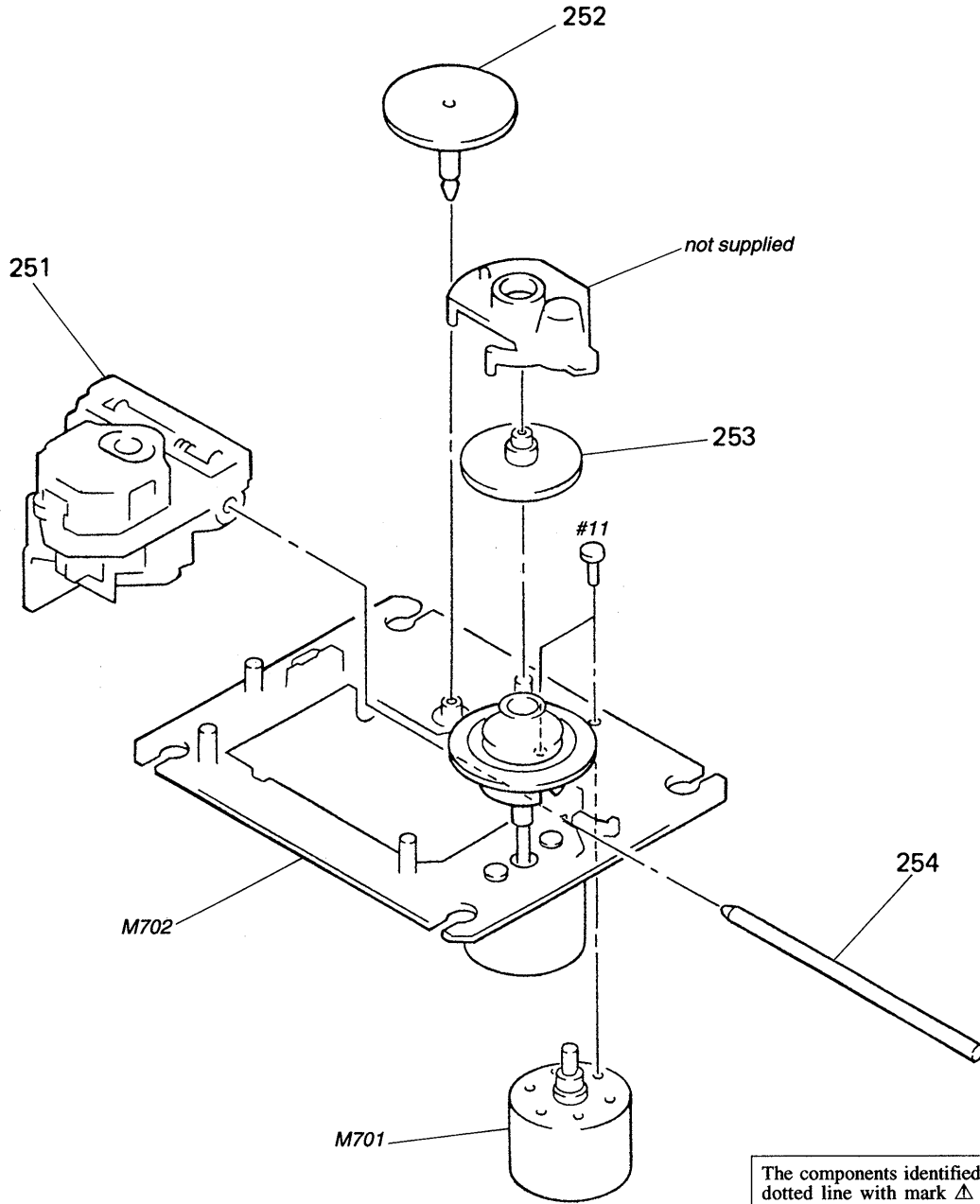

The components identified by mark  $\Delta$  or dotted line with mark  $\Delta$  are critical for safety.  
Replace only with part number specified.

Ref. No.	Part No.	Description	Remark	Ref. No.	Part No.	Description	Remark
$\Delta$ 251	8-848-376-01	OPTICAL PICK-UP KSS-213B		254	2-626-908-01	SHAFT, SLED	
252	2-626-907-01	GEAR (A) (S)		M701	X-2625-769-1	GEAR ASSY (MB), MOTOR (SLED)	
253	2-627-003-01	GEAR (B) (RP)		M702	X-2625-770-1	CHASSIS ASSY (MB) (RP), MOTOR (SPINDLE)	

**(7) SPEAKER SECTION**

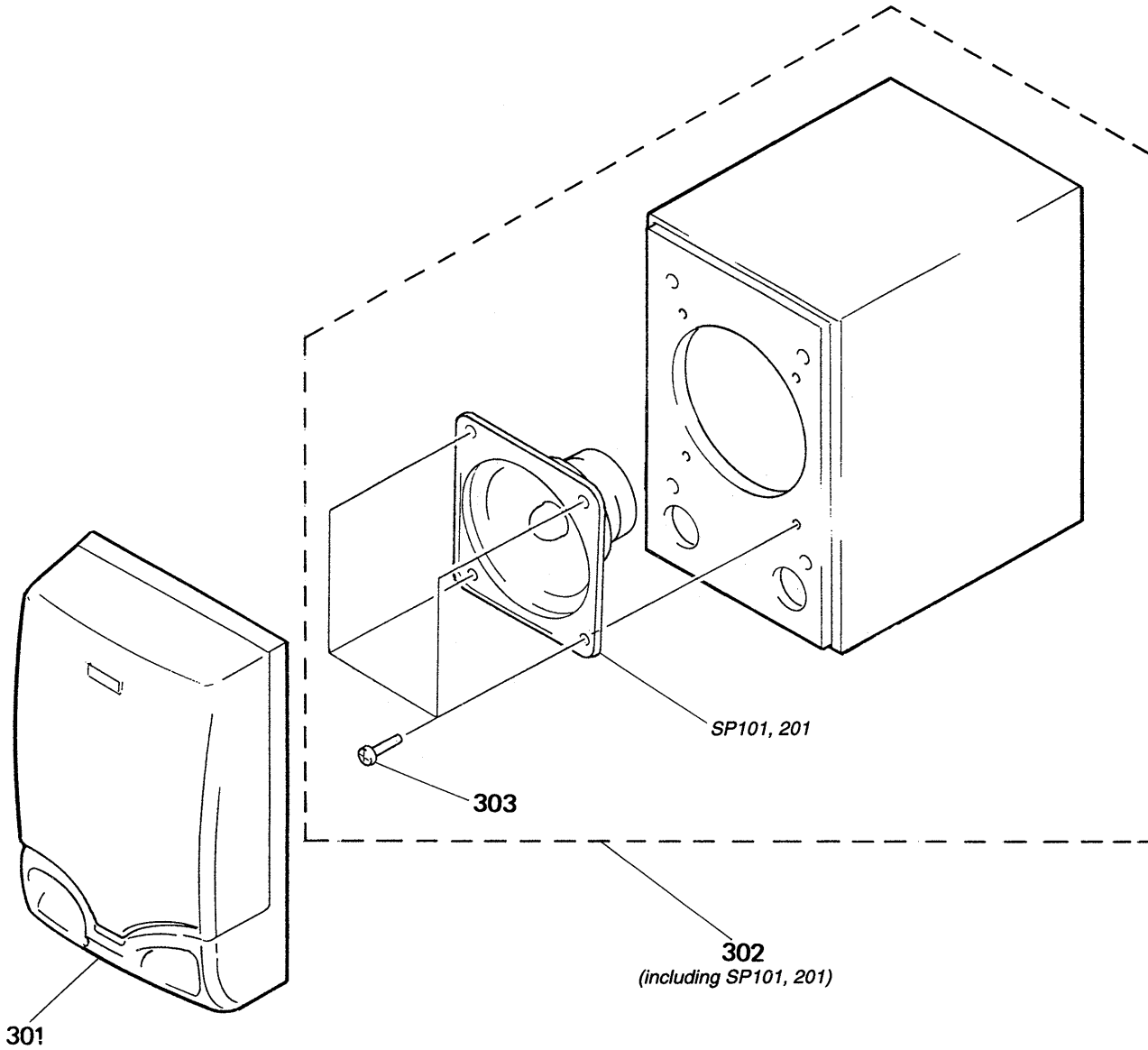

Ref.No.	Part No.	Description	Remark	Ref.No.	Part No.	Description	Remark
301	X-3371-005-1	PANEL ASSY, SPEAKER		303	4-874-614-61	SCREW (4) (3.5X16), TAPPING	
302	X-3372-678-1	BOX ASSY, SPEAKER					

# SECTION 7 ELECTRICAL PARTS LIST

CD

**NOTE:**

- Due to standardization, replacements in the parts list may be different from the parts specified in the diagrams or the components used on the set.
- -XX and -X mean standardized parts, so they may have some difference from the original one.
- RESISTORS  
All resistors are in ohms.  
METAL: Metal-film resistor.  
METAL OXIDE: Metal oxide-film resistor.  
F: nonflammable

- Items marked "\*" are not stocked since they are seldom required for routine service. Some delay should be anticipated when ordering these items.
- SEMICONDUCTORS  
In each case, u:  $\mu$ , for example:  
uA ..:  $\mu$ A.    uPA..:  $\mu$ PA.  
uPB..:  $\mu$ PB.    uPC..:  $\mu$ PC.    uPD..:  $\mu$ PD.
- CAPACITORS  
uF:  $\mu$ F
- COILS  
uH:  $\mu$ H

The components identified by mark  $\triangle$  or dotted line with mark  $\triangle$  are critical for safety. Replace only with part number specified.

When indicating parts by reference number, please include the board.

Ref. No.	Part No.	Description	Remark	Ref. No.	Part No.	Description	Remark
*	A-3306-101-A	CD BOARD, COMPLETE *****					
		< CAPACITOR >					
C700	1-162-306-11	CERAMIC	0.01uF 30% 16V	C734	1-130-481-00	MYLAR	0.0068uF 5% 50V
C701	1-162-302-11	CERAMIC	0.0022uF 20% 16V	C737	1-162-294-31	CERAMIC	0.001uF 10% 50V
C702	1-136-165-00	FILM	0.1uF 5% 50V	C738	1-162-294-31	CERAMIC	0.001uF 10% 50V
C703	1-136-165-00	FILM	0.1uF 5% 50V	C741	1-104-664-11	ELECT	47uF 20% 10V
C704	1-136-165-00	FILM	0.1uF 5% 50V	C742	1-136-173-00	FILM	0.47uF 5% 50V
C705	1-131-375-00	TANTALUM	4.7uF 10% 10V	C743	1-162-290-31	CERAMIC	470PF 10% 50V
C706	1-130-489-00	MYLAR	0.033uF 5% 50V	C744	1-162-286-21	CERAMIC	220PF 10% 50V
C707	1-130-486-00	MYLAR	0.018uF 10% 50V	C745	1-136-169-00	FILM	0.22uF 5% 50V
C708	1-162-199-31	CERAMIC	10PF 5% 50V	C746	1-162-306-11	CERAMIC	0.01uF 30% 16V
C709	1-126-962-11	ELECT	3.3uF 20% 50V	C747	1-130-483-00	MYLAR	0.01uF 5% 50V
C710	1-130-493-00	MYLAR	0.068uF 5% 50V	C750	1-164-159-21	CERAMIC	0.1uF 50V
C711	1-162-215-31	CERAMIC	47PF 5% 50V	C752	1-162-199-31	CERAMIC	10PF 5% 50V
C712	1-162-306-11	CERAMIC	0.01uF 30% 16V	C753	1-162-199-31	CERAMIC	10PF 5% 50V
C713	1-130-489-00	MYLAR	0.033uF 5% 50V	C754	1-104-666-11	ELECT	220uF 20% 10V
C714	1-162-306-11	CERAMIC	0.01uF 30% 16V	C755	1-164-159-21	CERAMIC	0.1uF 50V
C715	1-130-489-00	MYLAR	0.033uF 5% 50V	C756	1-162-306-11	CERAMIC	0.01uF 30% 16V
C716	1-136-169-00	FILM	0.22uF 5% 50V	C758	1-162-282-31	CERAMIC	100PF 10% 50V
C717	1-104-664-11	ELECT	47uF 20% 10V	C759	1-162-306-11	CERAMIC	0.01uF 30% 16V
C718	1-124-907-11	ELECT	10uF 20% 50V	C760	1-104-666-11	ELECT	220uF 20% 10V
C721	1-130-491-00	MYLAR	0.047uF 5% 50V	C763	1-162-600-11	CERAMIC	0.0047uF 30% 16V
C722	1-161-494-00	CERAMIC	0.022uF 25V	C764	1-126-963-11	ELECT	4.7uF 20% 50V
C723	1-130-495-00	MYLAR	0.1uF 5% 50V	C773	1-162-600-11	CERAMIC	0.0047uF 30% 16V
C725	1-162-199-31	CERAMIC	10PF 5% 50V	C774	1-126-963-11	ELECT	4.7uF 20% 50V
C726	1-162-294-31	CERAMIC	0.001uF 10% 50V	C780	1-162-294-31	CERAMIC	0.001uF 10% 50V
C727	1-162-306-11	CERAMIC	0.01uF 30% 16V	C781	1-104-666-11	ELECT	220uF 20% 10V
C728	1-164-159-21	CERAMIC	0.1uF 50V	C782	1-162-294-31	CERAMIC	0.001uF 10% 50V
C729	1-104-664-11	ELECT	47uF 20% 10V	C783	1-162-306-11	CERAMIC	0.01uF 30% 16V
C730	1-124-472-11	ELECT	470uF 20% 10V	C784	1-130-491-00	MYLAR	0.047uF 5% 50V
C731	1-162-294-31	CERAMIC	0.001uF 10% 50V	C787	1-104-666-11	ELECT	220uF 20% 10V
C732	1-130-484-00	MYLAR	0.012uF 5% 50V	C788	1-162-294-31	CERAMIC	0.001uF 10% 50V
				C790	1-124-902-00	ELECT	0.47uF 20% 50V
				C792	1-162-282-31	CERAMIC	100PF 10% 50V
				C793	1-162-282-31	CERAMIC	100PF 10% 50V
				C794	1-162-282-31	CERAMIC	100PF 10% 50V
				C796	1-162-306-11	CERAMIC	0.01uF 30% 16V

Ref. No.	Part No.	Description	Remark
< CONNECTOR >			
CNP701	1-770-168-11	CONNECTOR, FFC/FPC 16P	
* CNP703	1-580-158-11	PIN, CONNECTOR (PC BOARD) 6P	
* CNP704	1-580-169-11	PIN, CONNECTOR (PC BOARD) 8P	
* CNP705	1-695-371-31	PIN, CONNECTOR (PC BOARD) 10P	
< DIODE >			
D702	8-719-987-63	DIODE 1N4148M	
D703	8-719-987-63	DIODE 1N4148M	
< IC >			
IC701	8-752-069-56	IC CXA1782BQ	
IC702	8-752-372-94	IC CXD2507AQ	
IC703	8-759-336-75	IC BA5930FP	
IC704	8-759-283-60	IC SM5875AM-ET	
< COIL/RESISTOR >			
L702	1-410-501-11	INDUCTOR 2.2uH	
L703	1-410-513-11	INDUCTOR 22uH	
L704	1-410-397-21	FERRITE BEAD INDUCTOR	
L705	1-410-397-21	FERRITE BEAD INDUCTOR	
L716	1-249-417-11	CARBON 1K 5%	1/4W
L717	1-249-417-11	CARBON 1K 5%	1/4W
L718	1-249-417-11	CARBON 1K 5%	1/4W
L719	1-249-417-11	CARBON 1K 5%	1/4W
L720	1-249-417-11	CARBON 1K 5%	1/4W
L742	1-410-397-21	FERRITE BEAD INDUCTOR	
L760	1-410-513-11	INDUCTOR 22uH	
L770	1-410-513-11	INDUCTOR 22uH	
< TRANSISTOR >			
Q701	8-729-801-84	TRANSISTOR 2SB1013-4	
Q702	8-729-900-85	TRANSISTOR DTC144WS	
Q703	8-729-900-74	TRANSISTOR DTC143TS	
Q705	8-729-902-80	TRANSISTOR DTA114YS	
Q760	8-729-900-74	TRANSISTOR DTC143TS	
Q770	8-729-900-74	TRANSISTOR DTC143TS	
< RESISTOR >			
R700	1-249-429-11	CARBON 10K 5%	1/4W
R701	1-249-441-11	CARBON 100K 5%	1/4W
R702	1-247-896-11	CARBON 510K 5%	1/4W
R703	1-249-441-11	CARBON 100K 5%	1/4W
R704	1-247-883-00	CARBON 150K 5%	1/4W
R705	1-249-437-11	CARBON 47K 5%	1/4W
R706	1-247-876-11	CARBON 75K 5%	1/4W
R707	1-249-432-11	CARBON 18K 5%	1/4W

Ref. No.	Part No.	Description	Remark
R708	1-247-883-00	CARBON 150K 5%	1/4W
R709	1-247-862-11	CARBON 20K 5%	1/4W
R710	1-249-393-11	CARBON 10 5%	1/4W
R714	1-247-883-00	CARBON 150K 5%	1/4W
R716	1-249-430-11	CARBON 12K 5%	1/4W
R717	1-249-429-11	CARBON 10K 5%	1/4W
R718	1-247-899-11	CARBON 680K 5%	1/4W
R720	1-247-891-00	CARBON 330K 5%	1/4W
R722	1-249-439-11	CARBON 68K 5%	1/4W
R723	1-249-440-11	CARBON 82K 5%	1/4W
R725	1-249-437-11	CARBON 47K 5%	1/4W
R726	1-249-429-11	CARBON 10K 5%	1/4W
R727	1-249-429-11	CARBON 10K 5%	1/4W
R730	1-249-435-11	CARBON 33K 5%	1/4W
R731	1-247-863-11	CARBON 22K 5%	1/4W
R732	1-249-429-11	CARBON 10K 5%	1/4W
R733	1-249-435-11	CARBON 33K 5%	1/4W
R734	1-249-437-11	CARBON 47K 5%	1/4W
R735	1-249-425-11	CARBON 4.7K 5%	1/4W
R736	1-249-429-11	CARBON 10K 5%	1/4W
R740	1-247-843-11	CARBON 3.3K 5%	1/4W
R741	1-249-417-11	CARBON 1K 5%	1/4W
R742	1-249-429-11	CARBON 10K 5%	1/4W
R743	1-247-903-00	CARBON 1M 5%	1/4W
R744	1-247-887-00	CARBON 220K 5%	1/4W
R745	1-249-429-11	CARBON 10K 5%	1/4W
R746	1-249-437-11	CARBON 47K 5%	1/4W
R748	1-249-429-11	CARBON 10K 5%	1/4W
R749	1-249-429-11	CARBON 10K 5%	1/4W
R750	1-249-417-11	CARBON 1K 5%	1/4W
R753	1-249-429-11	CARBON 10K 5%	1/4W
R755	1-249-429-11	CARBON 10K 5%	1/4W
R756	1-249-440-11	CARBON 82K 5%	1/4W
R757	1-249-439-11	CARBON 68K 5%	1/4W
R758	1-249-439-11	CARBON 68K 5%	1/4W
R759	1-249-439-11	CARBON 68K 5%	1/4W
R766	1-249-417-11	CARBON 1K 5%	1/4W
R776	1-249-417-11	CARBON 1K 5%	1/4W
R790	1-247-863-11	CARBON 22K 5%	1/4W
R791	1-249-425-11	CARBON 4.7K 5%	1/4W
R792	1-249-429-11	CARBON 10K 5%	1/4W

< VARIABLE RESISTOR >

RV701	1-230-497-11	RES, ADJ, CARBON 22K
RV702	1-230-497-11	RES, ADJ, CARBON 22K
RV703	1-223-459-21	RES, ADJ, CERMET 2.2K
RV704	1-230-497-11	RES, ADJ, CARBON 22K

Ref. No.	Part No.	Description	Remark
< VIBRATOR >			
X701	1-579-345-11	VIBRATOR, CERAMIC (16.934MHz)	
*****			
*	1-662-589-11	CD MOTOR BOARD	
*****			
< SWITCH >			
S702	1-571-936-11	SWITCH, LEAF (LIMIT)	
*****			
*	A-3306-098-A	CONTROL BOARD, COMPLETE	
*****			
	3-928-783-01	HOLDER, LCD	
	3-928-784-01	HOLDER, LED	
< CAPACITOR >			
C801	1-162-306-11	CERAMIC	0.01uF 30% 16V
C802	1-162-306-11	CERAMIC	0.01uF 30% 16V
C805	1-124-443-00	ELECT	100uF 20% 10V
C806	1-162-306-11	CERAMIC	0.01uF 30% 16V
C814	1-162-306-11	CERAMIC	0.01uF 30% 16V
C815	1-124-907-11	ELECT	10uF 20% 50V
C816	1-162-294-31	CERAMIC	0.001uF 10% 50V
C818	1-162-294-31	CERAMIC	0.001uF 10% 50V
C819	1-162-294-31	CERAMIC	0.001uF 10% 50V
C820	1-162-294-31	CERAMIC	0.001uF 10% 50V
C821	1-162-294-31	CERAMIC	0.001uF 10% 50V
C822	1-102-958-00	CERAMIC	20PF 5% 50V
C823	1-102-958-00	CERAMIC	20PF 5% 50V
C824	1-104-664-11	ELECT	47uF 20% 10V
C825	1-162-282-31	CERAMIC	100PF 10% 50V
C826	1-164-159-21	CERAMIC	0.1uF 50V
C827	1-164-159-21	CERAMIC	0.1uF 50V
C828	1-164-159-21	CERAMIC	0.1uF 50V
C829	1-164-159-21	CERAMIC	0.1uF 50V
C830	1-124-443-00	ELECT	100uF 20% 10V
C831	1-162-306-11	CERAMIC	0.01uF 30% 16V
< CONNECTOR >			
CNP801	1-695-383-31	PIN, CONNECTOR (PC BOARD)	22P
* CNP803	1-695-333-41	PIN, CONNECTOR (PC BOARD)	10P
* CNP804	1-580-158-11	PIN, CONNECTOR (PC BOARD)	6P
< DIODE >			
D801	8-719-055-35	DIODE	KLR2303/N (POWER/STANDBY)
D802	8-719-987-63	DIODE	1N4148M

Ref. No.	Part No.	Description	Remark
< IC >			
IC801	8-759-371-17	IC	MSM65353-021GS-BK4
IC802	8-759-165-81	IC	PST600D-T
IC803	8-759-336-03	IC	S-2900ADP
IC804	8-749-923-11	IC	GP1U58XB
< COIL >			
L801	1-410-336-11	INDUCTOR	220uH
L802	1-414-142-11	INDUCTOR	1uH
< LIQUID CRYSTAL DISPLAY >			
LCD801	1-810-791-11	DISPLAY PANEL, LIQUID CRYSTAL	
< TRANSISTOR >			
Q801	8-729-901-57	TRANSISTOR	DTC143XS
< RESISTOR >			
R805	1-249-425-11	CARBON	4.7K 5% 1/4W
R806	1-249-425-11	CARBON	4.7K 5% 1/4W
R807	1-249-425-11	CARBON	4.7K 5% 1/4W
R808	1-249-425-11	CARBON	4.7K 5% 1/4W
R809	1-249-437-11	CARBON	47K 5% 1/4W
R810	1-249-437-11	CARBON	47K 5% 1/4W
R811	1-249-437-11	CARBON	47K 5% 1/4W
R812	1-249-417-11	CARBON	1K 5% 1/4W
R813	1-249-419-11	CARBON	1.5K 5% 1/4W
R814	1-249-417-11	CARBON	1K 5% 1/4W
R815	1-249-417-11	CARBON	1K 5% 1/4W
R816	1-249-417-11	CARBON	1K 5% 1/4W
R827	1-249-417-11	CARBON	1K 5% 1/4W
R833	1-249-437-11	CARBON	47K 5% 1/4W
R834	1-247-888-11	CARBON	240K 5% 1/4W
R835	1-247-883-00	CARBON	150K 5% 1/4W
R836	1-247-883-00	CARBON	150K 5% 1/4W
R837	1-247-883-00	CARBON	150K 5% 1/4W
R838	1-249-417-11	CARBON	1K 5% 1/4W
R839	1-249-417-11	CARBON	1K 5% 1/4W
R840	1-249-417-11	CARBON	1K 5% 1/4W
R841	1-249-417-11	CARBON	1K 5% 1/4W
R843	1-249-417-11	CARBON	1K 5% 1/4W
R844	1-249-417-11	CARBON	1K 5% 1/4W
R845	1-249-417-11	CARBON	1K 5% 1/4W
R846	1-249-419-11	CARBON	1.5K 5% 1/4W
R847	1-249-417-11	CARBON	1K 5% 1/4W
R848	1-249-401-11	CARBON	47 5% 1/4W
R849	1-249-435-11	CARBON	33K 5% 1/4W
R850	1-249-418-11	CARBON	1.2K 5% 1/4W

<b>CONTROL</b>	<b>KEY</b>	<b>LAMP</b>	<b>MAIN</b>
----------------	------------	-------------	-------------

Ref. No.	Part No.	Description			Remark
R851	1-249-416-11	CARBON	820	5%	1/4W
R852	1-249-415-11	CARBON	680	5%	1/4W
R853	1-249-415-11	CARBON	680	5%	1/4W
R855	1-249-416-11	CARBON	820	5%	1/4W
R856	1-249-437-11	CARBON	47K	5%	1/4W
R857	1-249-411-11	CARBON	330	5%	1/4W
< SWITCH >					
S801	1-762-513-11	SWITCH, KEY BOARD (VOLUME +)			
S802	1-762-513-11	SWITCH, KEY BOARD (VOLUME -)			
S803	1-762-513-11	SWITCH, KEY BOARD (POWER)			
S804	1-762-513-11	SWITCH, KEY BOARD (TUNING +)			
S805	1-762-513-11	SWITCH, KEY BOARD (TUNING -)			
< VIBRATOR >					
X801	1-567-775-11	VIBRATOR, CERAMIC (4.19MHz)			
X802	1-760-305-11	VIBRATOR, CRYSTAL (32.768kHz)			
*****					
*	A-3306-097-A	KEY BOARD, COMPLETE			
*****					
< DIODE >					
D861	8-719-940-82	DIODE SLR34MC3 (CD)			
D862	8-719-940-82	DIODE SLR34MC3 (CD)			
D863	8-719-940-82	DIODE SLR34MC3 (CD)			
D864	8-719-940-82	DIODE SLR34MC3 (RADIO)			
D865	8-719-940-82	DIODE SLR34MC3 (RADIO)			
D866	8-719-940-82	DIODE SLR34MC3 (RADIO)			
< TRANSISTOR >					
Q861	8-729-901-57	TRANSISTOR DTC143XS			
Q862	8-729-901-57	TRANSISTOR DTC143XS			
< RESISTOR >					
R861	1-249-427-11	CARBON	6.8K	5%	1/4W
R862	1-247-843-11	CARBON	3.3K	5%	1/4W
R863	1-249-420-11	CARBON	1.8K	5%	1/4W
R864	1-249-418-11	CARBON	1.2K	5%	1/4W
R865	1-249-416-11	CARBON	820	5%	1/4W
R866	1-249-415-11	CARBON	680	5%	1/4W
R867	1-247-864-11	CARBON	24K	5%	1/4W
R868	1-247-843-11	CARBON	3.3K	5%	1/4W
R869	1-249-420-11	CARBON	1.8K	5%	1/4W
R870	1-249-418-11	CARBON	1.2K	5%	1/4W
R872	1-249-413-11	CARBON	470	5%	1/4W
R873	1-249-413-11	CARBON	470	5%	1/4W
R874	1-249-413-11	CARBON	470	5%	1/4W
R875	1-249-413-11	CARBON	470	5%	1/4W

Ref. No.	Part No.	Description			Remark
R876	1-249-413-11	CARBON	470	5%	1/4W
R877	1-249-413-11	CARBON	470	5%	1/4W
< SWITCH >					
S861	1-762-513-11	SWITCH, KEY BOARD (PRESET -)			
S862	1-762-513-11	SWITCH, KEY BOARD (PRESET +)			
S863	1-762-513-11	SWITCH, KEY BOARD (BAND)			
S864	1-762-513-11	SWITCH, KEY BOARD (◀)			
S865	1-762-513-11	SWITCH, KEY BOARD (▶)			
S866	1-762-513-11	SWITCH, KEY BOARD (■)			
S867	1-762-513-11	SWITCH, KEY BOARD (▶II)			
S868	1-762-513-11	SWITCH, KEY BOARD (MONO/ST PLAY MODE)			
S869	1-762-513-11	SWITCH, KEY BOARD (ENTER/MEM DISPLAY)			
S870	1-762-513-11	SWITCH, KEY BOARD (SOUND)			
S871	1-762-513-11	SWITCH, KEY BOARD (MEGA BASS)			
*****					
*	1-662-590-11	LAMP BOARD			
*****					
< PILOT LAMP >					
PL801	1-517-474-11	LAMP, PILOT			
PL802	1-517-474-11	LAMP, PILOT			
PL803	1-517-474-11	LAMP, PILOT			
*****					
*	A-3293-236-A	MAIN BOARD, COMPLETE			
*****					
< ANTENNA >					
ANT1	1-694-215-11	ANTENNA (FM)			
< CAPACITOR >					
C1	1-163-109-00	CERAMIC CHIP	47PF	5%	50V
C2	1-163-031-11	CERAMIC CHIP	0.01uF		50V
C3	1-163-031-11	CERAMIC CHIP	0.01uF		50V
C4	1-163-133-00	CERAMIC CHIP	470PF	5%	50V
C5	1-163-031-11	CERAMIC CHIP	0.01uF		50V
C7	1-162-306-11	CERAMIC	0.01uF	30%	16V
C8	1-163-097-00	CERAMIC CHIP	15PF	5%	50V
C9	1-163-129-00	CERAMIC CHIP	330PF	5%	50V
C10	1-163-038-00	CERAMIC CHIP	0.1uF		25V
C11	1-163-141-00	CERAMIC CHIP	0.001uF	5%	50V
C12	1-124-907-11	ELECT	10uF	20%	50V
C13	1-163-031-11	CERAMIC CHIP	0.01uF		50V
C14	1-164-344-11	CERAMIC CHIP	0.068uF	10%	25V
C15	1-164-345-11	CERAMIC CHIP	0.082uF	10%	25V
C16	1-164-345-11	CERAMIC CHIP	0.082uF	10%	25V

Ref. No.	Part No.	Description	Remark	Ref. No.	Part No.	Description	Remark
C17	1-126-963-11	ELECT	4.7uF 20% 50V	C82	1-164-054-11	CERAMIC 22PF 5% 50V	
C18	1-124-443-00	ELECT	100uF 20% 10V	C83	1-163-031-11	CERAMIC CHIP 0.01uF 50V	
C19	1-163-031-11	CERAMIC CHIP	0.01uF 50V	C84	1-163-125-00	CERAMIC CHIP 220PF 5% 50V	
C20	1-164-232-11	CERAMIC CHIP	0.01uF 50V	C85	1-163-009-11	CERAMIC CHIP 0.001uF 10% 50V	
C21	1-163-095-00	CERAMIC CHIP	12PF 5% 50V	C86	1-163-038-00	CERAMIC CHIP 0.1uF 25V	
C22	1-163-031-11	CERAMIC CHIP	0.01uF 50V	C90	1-163-031-11	CERAMIC CHIP 0.01uF 50V	
C23	1-124-463-00	CERAMIC CHIP	0.027uF 10% 25V	C91	1-163-117-00	CERAMIC CHIP 100PF 5% 50V	
C24	1-124-463-00	CERAMIC CHIP	0.027uF 10% 25V	C101	1-163-139-00	CERAMIC CHIP 820PF 5% 50V	
C25	1-163-038-00	CERAMIC CHIP	0.1uF 25V	C102	1-163-117-00	CERAMIC CHIP 100PF 5% 50V	
C26	1-124-903-11	ELECT	1uF 20% 50V	C104	1-163-005-11	CERAMIC CHIP 470PF 10% 50V	
C27	1-124-903-11	ELECT	1uF 20% 50V	C106	1-163-117-00	CERAMIC CHIP 100PF 5% 50V	
C28	1-164-232-11	CERAMIC CHIP	0.01uF 50V	C107	1-163-986-00	CERAMIC CHIP 0.027uF 10% 25V	
C29	1-163-009-11	CERAMIC CHIP	0.001uF 10% 50V	C108	1-104-664-11	ELECT 47uF 20% 10V	
C30	1-163-009-11	CERAMIC CHIP	0.001uF 10% 50V	C109	1-124-907-11	ELECT 10uF 20% 50V	
C31	1-163-009-11	CERAMIC CHIP	0.001uF 10% 50V	C110	1-124-907-11	ELECT 10uF 20% 50V	
C32	1-162-294-31	CERAMIC	1000PF 10% 50V	C111	1-163-020-00	CERAMIC CHIP 0.0082uF 10% 50V	
C33	1-164-159-21	CERAMIC CHIP	0.1uF 25V	C113	1-124-907-11	ELECT 10uF 20% 50V	
C44	1-162-294-31	CERAMIC	0.001uF 10% 50V	C114	1-124-463-00	ELECT 0.1uF 20% 50V	
C45	1-136-177-00	FILM	1uF 5% 50V	C115	1-124-907-11	ELECT 10uF 20% 50V	
C46	1-124-907-11	ELECT	10uF 20% 50V	C116	1-162-587-11	CERAMIC CHIP 0.039uF 10% 25V	
C48	1-126-963-11	ELECT	4.7uF 20% 50V	C117	1-163-023-00	CERAMIC CHIP 0.015uF 5% 50V	
C49	1-163-031-11	CERAMIC CHIP	0.01uF 50V	C118	1-163-020-00	CERAMIC CHIP 0.0082uF 10% 50V	
C50	1-163-009-11	CERAMIC CHIP	0.001uF 10% 50V	C119	1-124-907-11	ELECT 10uF 20% 50V	
C51	1-163-009-11	CERAMIC CHIP	0.001uF 10% 50V	C120	1-126-963-11	ELECT 4.7uF 20% 50V	
C53	1-163-009-11	CERAMIC CHIP	0.001uF 10% 50V	C121	1-163-018-00	CERAMIC CHIP 0.0056uF 5% 50V	
C54	1-163-239-11	CERAMIC CHIP	33PF 5% 50V	C122	1-163-024-00	CERAMIC CHIP 0.018uF 10% 50V	
C55	1-163-227-11	CERAMIC CHIP	10PF 0.5PF 50V	C123	1-163-037-11	CERAMIC CHIP 0.022uF 10% 25V	
C56	1-163-009-11	CERAMIC CHIP	0.001uF 10% 50V	C124	1-163-809-11	CERAMIC CHIP 0.047uF 10% 25V	
C57	1-163-133-00	CERAMIC CHIP	470PF 5% 50V	C125	1-163-809-11	CERAMIC CHIP 0.047uF 10% 25V	
C58	1-163-031-11	CERAMIC CHIP	0.01uF 50V	C127	1-164-004-11	CERAMIC CHIP 0.1uF 10% 25V	
C59	1-163-031-11	CERAMIC CHIP	0.01uF 50V	C128	1-124-907-11	ELECT 10uF 20% 50V	
C60	1-126-963-11	ELECT	4.7uF 20% 50V	C129	1-163-117-00	CERAMIC CHIP 100PF 5% 50V	
C61	1-163-009-11	CERAMIC CHIP	0.001uF 10% 50V	C130	1-164-004-11	CERAMIC CHIP 0.1uF 10% 25V	
C62	1-163-009-11	CERAMIC CHIP	0.001uF 10% 50V	C132	1-163-009-11	CERAMIC CHIP 0.001uF 10% 50V	
C63	1-163-038-00	CERAMIC CHIP	0.1uF 25V	C133	1-124-903-11	ELECT 1uF 20% 50V	
C64	1-163-031-11	CERAMIC CHIP	0.01uF 50V	C134	1-124-903-11	ELECT 1uF 20% 50V	
C65	1-163-025-11	CERAMIC CHIP	0.001uF 50V	C135	1-163-117-00	CERAMIC CHIP 100PF 5% 50V	
C66	1-126-963-11	ELECT	4.7uF 20% 50V	C136	1-163-038-00	CERAMIC CHIP 0.1uF 25V	
C67	1-163-009-11	CERAMIC CHIP	0.001uF 10% 50V	C137	1-124-903-11	ELECT 1uF 20% 50V	
C68	1-163-109-00	CERAMIC CHIP	47PF 5% 50V	C138	1-164-004-11	CERAMIC CHIP 0.1uF 10% 25V	
C69	1-163-031-11	CERAMIC CHIP	0.01uF 50V	C139	1-163-117-00	CERAMIC CHIP 100PF 5% 50V	
C71	1-163-009-11	CERAMIC CHIP	0.001uF 10% 50V	C143	1-124-903-11	ELECT 1uF 20% 50V	
C72	1-126-965-11	ELECT	22uF 20% 50V	C144	1-163-117-00	CERAMIC CHIP 100PF 5% 50V	
C74	1-163-009-11	CERAMIC CHIP	0.001uF 10% 50V	C146	1-164-161-11	CERAMIC CHIP 0.0022uF 10% 100V	
C76	1-162-306-11	CERAMIC	0.01uF 30% 16V	C151	1-163-009-11	CERAMIC CHIP 0.001uF 10% 50V	
C77	1-163-031-11	CERAMIC CHIP	0.01uF 50V	C152	1-164-004-11	CERAMIC CHIP 0.1uF 10% 25V	
C78	1-163-031-11	CERAMIC CHIP	0.01uF 50V	C153	1-163-117-00	CERAMIC CHIP 100PF 5% 50V	
C79	1-163-009-11	CERAMIC CHIP	0.001uF 10% 50V	C154	1-163-038-00	CERAMIC CHIP 0.1uF 25V	
C81	1-163-101-00	CERAMIC CHIP	22PF 5% 50V				

# MAIN

Ref. No.	Part No.	Description	Remark			Ref. No.	Part No.	Description	Remark		
C201	1-163-139-00	CERAMIC CHIP	820PF	5%	50V	C308	1-106-367-00	FILM	0.01uF	5%	100V
C202	1-163-117-00	CERAMIC CHIP	100PF	5%	50V	C309	1-164-232-11	CERAMIC CHIP	0.01uF		50V
C204	1-163-005-11	CERAMIC CHIP	470PF	10%	50V	C310	1-163-019-00	CERAMIC CHIP	0.0068uF	10%	50V
C206	1-163-117-00	CERAMIC CHIP	100PF	5%	50V	C311	1-163-019-00	CERAMIC CHIP	0.0068uF	10%	50V
C207	1-163-986-00	CERAMIC CHIP	0.027uF	10%	25V	C312	1-163-023-00	CERAMIC CHIP	0.015uF	5%	50V
C208	1-104-664-11	ELECT	47uF	20%	10V	C313	1-126-963-11	ELECT	4.7uF	20%	50V
C209	1-124-907-11	ELECT	10uF	20%	50V	C314	1-124-903-11	ELECT	1uF	20%	50V
C210	1-124-907-11	ELECT	10uF	20%	50V	C315	1-163-009-11	CERAMIC CHIP	0.001uF	10%	50V
C211	1-163-020-00	CERAMIC CHIP	0.0082uF	10%	50V	C316	1-126-965-11	ELECT	22uF	20%	50V
C213	1-124-907-11	ELECT	10uF	20%	50V	C317	1-126-965-11	ELECT	22uF	20%	50V
C214	1-124-463-00	ELECT	0.1uF	20%	50V	C318	1-126-233-11	ELECT	22uF	20%	50V
C215	1-124-907-11	ELECT	10uF	20%	50V	C319	1-161-772-11	CERAMIC	0.1uF	20%	25V
C216	1-162-587-11	CERAMIC CHIP	0.039uF	10%	25V	C320	1-163-009-11	CERAMIC CHIP	0.001uF	10%	50V
C217	1-163-023-00	CERAMIC CHIP	0.015uF	5%	50V	C321	1-124-902-00	ELECT	0.47uF	20%	50V
C218	1-163-020-00	CERAMIC CHIP	0.0082uF	10%	50V	C322	1-126-963-11	ELECT	4.7uF	20%	50V
C219	1-124-907-11	ELECT	10uF	20%	50V	C323	1-126-233-11	ELECT	22uF	20%	50V
C220	1-126-963-11	ELECT	4.7uF	20%	50V	C325	1-124-564-11	ELECT	4700uF	20%	25V
C221	1-163-018-00	CERAMIC CHIP	0.0056uF	5%	50V	C326	1-124-564-11	ELECT	4700uF	20%	25V
C222	1-163-024-00	CERAMIC CHIP	0.018uF	10%	50V	C327	1-164-232-11	CERAMIC CHIP	0.01uF		50V
C223	1-163-037-11	CERAMIC CHIP	0.022uF	10%	25V	C330	1-163-037-11	CERAMIC CHIP	0.022uF	10%	25V
C224	1-163-809-11	CERAMIC CHIP	0.047uF	10%	25V	C331	1-163-037-11	CERAMIC CHIP	0.022uF	10%	25V
C225	1-163-809-11	CERAMIC CHIP	0.047uF	10%	25V	C332	1-164-232-11	CERAMIC CHIP	0.01uF		50V
C227	1-164-004-11	CERAMIC CHIP	0.1uF	10%	25V	C336	1-126-937-11	ELECT	4700uF	20%	16V
C228	1-124-907-11	ELECT	10uF	20%	50V	C338	1-124-907-11	ELECT	10uF	20%	50V
C229	1-163-117-00	CERAMIC CHIP	100PF	5%	50V	C339	1-104-664-11	ELECT	47uF	20%	10V
C230	1-164-004-11	CERAMIC CHIP	0.1uF	10%	25V	C341	1-124-907-11	ELECT	10uF	20%	50V
C232	1-163-009-11	CERAMIC CHIP	0.001uF	10%	50V	C342	1-124-907-11	ELECT	10uF	20%	50V
C233	1-124-903-11	ELECT	1uF	20%	50V	C343	1-104-664-11	ELECT	47uF	20%	10V
C234	1-124-903-11	ELECT	1uF	20%	50V	C344	1-104-664-11	ELECT	47uF	20%	10V
C235	1-163-117-00	CERAMIC CHIP	100PF	5%	50V	C346	1-124-907-11	ELECT	10uF	20%	50V
C236	1-163-038-00	CERAMIC CHIP	0.1uF		25V	C347	1-104-666-11	ELECT	220uF	20%	10V
C237	1-124-903-11	ELECT	1uF	20%	50V	C348	1-104-665-11	ELECT	100uF	20%	16V
C238	1-164-004-11	CERAMIC CHIP	0.1uF	10%	25V	C349	1-104-664-11	ELECT	47uF	20%	10V
C239	1-163-117-00	CERAMIC CHIP	100PF	5%	50V	C350	1-164-232-11	CERAMIC CHIP	0.01uF		50V
C243	1-124-903-11	ELECT	1uF	20%	50V	C351	1-163-989-11	CERAMIC CHIP	0.033uF	10%	25V
C244	1-163-117-00	CERAMIC CHIP	100PF	5%	50V	C352	1-163-117-00	CERAMIC CHIP	100PF	5%	50V
C246	1-164-161-11	CERAMIC CHIP	0.0022uF	10%	100V	C353	1-124-903-11	ELECT	1uF	20%	50V
C251	1-163-009-11	CERAMIC CHIP	0.001uF	10%	50V	C354	1-163-009-11	CERAMIC CHIP	0.001uF	10%	50V
C252	1-164-004-11	CERAMIC CHIP	0.1uF	10%	25V	C355	1-163-117-00	CERAMIC CHIP	100PF	5%	50V
C253	1-163-117-00	CERAMIC CHIP	100PF	5%	50V	C356	1-104-664-11	ELECT	47uF	20%	10V
C254	1-163-038-00	CERAMIC CHIP	0.1uF		25V	C357	1-161-772-11	CERAMIC	0.1uF	20%	25V
C301	1-164-232-11	CERAMIC CHIP	0.01uF		50V	C358	1-124-463-00	ELECT	0.1uF	20%	50V
C302	1-104-664-11	ELECT	47uF	20%	10V	C360	1-124-907-11	ELECT	10uF	20%	50V
C303	1-104-663-11	ELECT	33uF	20%	16V	C366	1-126-941-11	ELECT	470uF	20%	16V
C304	1-104-663-11	ELECT	33uF	20%	16V	C367	1-164-232-11	CERAMIC CHIP	0.01uF		50V
C305	1-124-907-11	ELECT	10uF	20%	50V	C368	1-164-232-11	CERAMIC CHIP	0.01uF		50V
C306	1-163-117-00	CERAMIC CHIP	100PF	5%	50V	C369	1-163-095-00	CERAMIC CHIP	12PF	5%	50V
C307	1-124-907-11	ELECT	10uF	20%	50V	C370	1-163-038-00	CERAMIC CHIP	0.1uF		25V
						C374	1-164-232-11	CERAMIC CHIP	0.01uF		50V

Ref. No.	Part No.	Description	Remark
C375	1-164-232-11	CERAMIC CHIP 0.01uF	50V
C376	1-126-233-11	ELECT 22uF	20% 50V
C377	1-163-009-11	CERAMIC CHIP 0.001uF	10% 50V
C378	1-163-038-00	CERAMIC CHIP 0.1uF	25V
C380	1-126-233-11	ELECT 22uF	20% 50V
C382	1-126-233-11	ELECT 22uF	20% 50V
C383	1-104-665-11	ELECT 100uF	20% 16V
C384	1-136-165-00	FILM 0.1uF	5% 50V
C385	1-136-165-00	FILM 0.1uF	5% 50V
C386	1-136-165-00	FILM 0.1uF	5% 50V
C387	1-164-232-11	CERAMIC CHIP 0.01uF	50V
C389	1-163-038-00	CERAMIC CHIP 0.1uF	25V
C390	1-124-907-11	ELECT 10uF	20% 50V
C392	1-163-038-00	CERAMIC CHIP 0.1uF	25V
C393	1-163-031-11	CERAMIC CHIP 0.01uF	50V
< FILTER >			
CF1	1-760-468-11	FILTER, CERAMIC	
CF2	1-760-468-11	FILTER, CERAMIC	
CF3	1-760-468-11	FILTER, CERAMIC	
CF4	1-579-762-11	VIBRATOR, CERAMIC	
< COMPOSITION CIRCUIT BLOCK >			
CFT1	1-239-173-11	ENCAPSULATED COMPONENT	
< CONNECTOR >			
* CNP301	1-580-158-11	PIN, CONNECTOR (PC BOARD) 6P	
* CNP302	1-691-581-11	PIN, CONNECTOR (PC BOARD) 10P	
CNP304	1-695-345-41	PIN, CONNECTOR (PC BOARD) 22P	
* CNP305	1-580-160-11	PIN, CONNECTOR (PC BOARD) 8P	
* CNP311	1-580-158-11	PIN, CONNECTOR (PC BOARD) 6P	
< TRIMMER >			
CT2	1-141-411-11	CAP, ADJ 20PF	
< DIODE >			
D3	8-719-050-69	DIODE KV1520NT	
D4	8-719-988-61	DIODE 1SS355TE-17	
D5	8-719-988-61	DIODE 1SS355TE-17	
D6	8-719-987-63	DIODE 1N4148M	
D8	8-719-987-63	DIODE 1N4148M	
D10	8-719-987-63	DIODE 1N4148M	
D11	8-719-987-63	DIODE 1N4148M	
D301	8-719-987-63	DIODE 1N4148M	
D302	8-719-987-63	DIODE 1N4148M	
D303	8-719-987-63	DIODE 1N4148M	
D304	8-719-987-63	DIODE 1N4148M	
D305	8-719-987-63	DIODE 1N4148M	

Ref. No.	Part No.	Description	Remark
D306	8-719-987-63	DIODE 1N4148M	
D308	8-719-987-63	DIODE 1N4148M	
D309	8-719-987-63	DIODE 1N4148M	
D310	8-719-921-42	DIODE MTZJ-5. 1A	
D311	8-719-046-07	DIODE 2A02M	
D318	8-719-987-63	DIODE 1N4148M	
D319	8-719-987-63	DIODE 1N4148M	
D323	8-719-987-63	DIODE 1N4148M	
D327	8-719-987-63	DIODE 1N4148M	
D328	8-719-987-63	DIODE 1N4148M	
D330	8-719-987-63	DIODE 1N4148M	
D331	8-719-987-63	DIODE 1N4148M	
D332	8-719-987-63	DIODE 1N4148M	
D333	8-719-987-63	DIODE 1N4148M	
D335	8-719-902-17	DIODE U15G	
D336	8-719-902-17	DIODE U15G	
D337	8-719-902-17	DIODE U15G	
D338	8-719-902-17	DIODE U15G	
< IC >			
IC1	8-759-386-02	IC TA2008AN	
IC3	8-759-333-33	IC BU2614	
IC301	1-809-920-11	IC BA7755A	
IC302	8-759-359-99	IC M51167BFP	
IC303	8-759-325-94	IC TDA7319	
IC304	8-759-711-35	IC NJM4580D	
IC305	8-759-190-89	IC TDA7265	
IC306	8-759-711-35	IC NJM4580D	
IC307	8-759-701-56	IC NJM78M05FA	
IC309	8-759-068-07	IC CD4052BCN	
IC310	8-759-634-51	IC M5218AP	
IC311	8-759-711-35	IC NJM4580D	
IC313	8-759-701-88	IC NJM7912FA	
< JACK >			
J1	1-778-310-11	CONNECTOR 2P (AM)	
J301	1-774-302-11	JACK (MIX MIC)	
J302	1-774-303-11	JACK (PHONES)	
J303	1-537-240-31	TERMINAL BOARD (CHECKER PIN) (SPEAKER)	
< CHIP CONDUCTOR >			
JR2	1-216-295-00	CONDUCTOR, CHIP	(2012)
JR3	1-216-295-00	CONDUCTOR, CHIP	(2012)
JR4	1-216-295-00	CONDUCTOR, CHIP	(2012)
JR5	1-216-295-00	CONDUCTOR, CHIP	(2012)
JR6	1-216-295-00	CONDUCTOR, CHIP	(2012)
JR7	1-216-295-00	CONDUCTOR, CHIP	(2012)
JR9	1-216-295-00	CONDUCTOR, CHIP	(2012)

**MAIN**

Ref. No.	Part No.	Description	Remark
< COIL >			
L1	1-410-443-21	INDUCTOR 1uH	
L3	1-411-586-11	COIL, AM ANT	
L4	1-411-234-11	COIL, AM OSC	
L5	1-410-336-11	INDUCTOR 220uH	
L6	1-410-443-21	INDUCTOR 1uH	
L7	1-410-521-11	INDUCTOR 100uH	
L9	1-410-509-11	INDUCTOR 10uH	
L11	1-233-306-31	ENCAPSULATED COMPONENT	
L102	1-410-775-11	INDUCTOR 10mH	
L103	1-415-921-11	INDUCTOR 1uH	
L104	1-410-397-21	FERRITE BEAD INDUCTOR	
L202	1-410-775-11	INDUCTOR 10mH	
L203	1-415-921-11	INDUCTOR 1uH	
L204	1-410-397-21	FERRITE BEAD INDUCTOR	
L302	1-410-521-11	INDUCTOR 100uH	
L303	1-410-509-11	INDUCTOR 10uH	
L304	1-410-509-11	INDUCTOR 10uH	
L305	1-410-509-11	INDUCTOR 10uH	
< TRANSISTOR >			
Q1	8-729-900-53	TRANSISTOR DTC114EK	
Q2	8-729-900-53	TRANSISTOR DTC114EK	
Q3	8-729-027-46	TRANSISTOR DTC114YKA-T146	
Q4	8-729-027-59	TRANSISTOR DTC144EKA-T146	
Q5	8-729-027-23	TRANSISTOR DTA114EKA-T146	
Q10	8-729-907-03	TRANSISTOR FMG5	
Q13	8-729-027-23	TRANSISTOR DTA114EKA-T146	
Q14	8-729-027-46	TRANSISTOR DTC114YKA-T146	
Q15	8-729-027-24	TRANSISTOR DTA114TKA-T146	
Q16	8-729-012-83	TRANSISTOR 2SK679A	
Q18	8-729-922-66	TRANSISTOR 2SC2410SN	
Q101	8-729-027-60	TRANSISTOR DTC144TKA-T146	
Q102	8-729-027-46	TRANSISTOR DTC114YKA-T146	
Q103	8-729-027-60	TRANSISTOR DTC144TKA-T146	
Q104	8-729-920-74	TRANSISTOR 2SC2412K-QR	
Q105	8-729-920-31	TRANSISTOR DTC343TK	
Q106	8-729-920-31	TRANSISTOR DTC343TK	
Q110	8-729-011-94	TRANSISTOR 2SK105ATP-3040	
Q111	8-729-027-24	TRANSISTOR DTA114TKA-T146	
Q112	8-729-027-24	TRANSISTOR DTA114TKA-T146	
Q201	8-729-027-60	TRANSISTOR DTC144TKA-T146	
Q202	8-729-027-46	TRANSISTOR DTC114YKA-T146	
Q203	8-729-027-60	TRANSISTOR DTC144TKA-T146	
Q204	8-729-920-74	TRANSISTOR 2SC2412K-QR	
Q205	8-729-920-31	TRANSISTOR DTC343TK	
Q206	8-729-920-31	TRANSISTOR DTC343TK	
Q210	8-729-011-94	TRANSISTOR 2SK105ATP-3040	

Ref. No.	Part No.	Description	Remark
Q211	8-729-027-24	TRANSISTOR DTA114TKA-T146	
Q212	8-729-027-24	TRANSISTOR DTA114TKA-T146	
Q301	8-729-920-74	TRANSISTOR 2SC2412K-QR	
Q302	8-729-920-74	TRANSISTOR 2SC2412K-QR	
Q303	8-729-027-26	TRANSISTOR DTA114YKA-T146	
Q304	8-729-027-46	TRANSISTOR DTC114YKA-T146	
Q305	8-729-027-23	TRANSISTOR DTA114EKA-T146	
Q306	8-729-920-74	TRANSISTOR 2SC2412K-QR	
Q307	8-729-027-26	TRANSISTOR DTA114YKA-T146	
Q308	8-729-027-60	TRANSISTOR DTC144TKA-T146	
Q309	8-729-920-74	TRANSISTOR 2SC2412K-QR	
Q310	8-729-920-31	TRANSISTOR DTC343TK	
Q311	8-729-027-26	TRANSISTOR DTA114YKA-T146	
Q312	8-729-027-46	TRANSISTOR DTC114YKA-T146	
Q313	8-729-027-46	TRANSISTOR DTC114YKA-T146	
Q315	8-729-027-60	TRANSISTOR DTC144TKA-T146	
Q317	8-729-801-84	TRANSISTOR 2SB1013-4	
Q318	8-729-027-46	TRANSISTOR DTC114YKA-T146	
Q319	8-729-027-26	TRANSISTOR DTA114YKA-T146	
Q320	8-729-027-46	TRANSISTOR DTC114YKA-T146	
Q322	8-729-920-31	TRANSISTOR DTC343TK	
< RESISTOR >			
R2	1-216-049-00	METAL GLAZE 1K 5% 1/10W	
R3	1-216-081-00	METAL CHIP 22K 5% 1/10W	
R4	1-216-073-00	METAL CHIP 10K 5% 1/10W	
R6	1-216-089-00	METAL GLAZE 47K 5% 1/10W	
R7	1-216-033-00	METAL CHIP 220 5% 1/10W	
R8	1-216-081-00	METAL CHIP 22K 5% 1/10W	
R9	1-216-057-00	METAL CHIP 2.2K 5% 1/10W	
R10	1-216-057-00	METAL CHIP 2.2K 5% 1/10W	
R14	1-216-017-00	METAL GLAZE 47 5% 1/10W	
R16	1-216-049-00	METAL GLAZE 1K 5% 1/10W	
R17	1-216-049-00	METAL GLAZE 1K 5% 1/10W	
R25	1-216-073-00	METAL CHIP 10K 5% 1/10W	
R26	1-216-065-00	METAL CHIP 4.7K 5% 1/10W	
R27	1-216-073-00	METAL CHIP 10K 5% 1/10W	
R28	1-216-073-00	METAL CHIP 10K 5% 1/10W	
R29	1-216-045-00	METAL CHIP 680 5% 1/10W	
R30	1-216-039-00	METAL CHIP 390 5% 1/10W	
R36	1-216-073-00	METAL CHIP 10K 5% 1/10W	
R37	1-216-073-00	METAL CHIP 10K 5% 1/10W	
R38	1-216-073-00	METAL CHIP 10K 5% 1/10W	
R39	1-216-073-00	METAL CHIP 10K 5% 1/10W	
R40	1-216-049-00	METAL GLAZE 1K 5% 1/10W	
R41	1-216-049-00	METAL GLAZE 1K 5% 1/10W	
R42	1-216-065-00	METAL CHIP 4.7K 5% 1/10W	
R43	1-216-089-00	METAL GLAZE 47K 5% 1/10W	

Ref. No.	Part No.	Description	Remark
R44	1-216-073-00	METAL CHIP	10K 5% 1/10W
R46	1-216-033-00	METAL CHIP	220 5% 1/10W
R55	1-216-049-00	METAL GLAZE	1K 5% 1/10W
R56	1-216-029-00	METAL CHIP	150 5% 1/10W
R57	1-216-013-00	METAL CHIP	33 5% 1/10W
R58	1-216-041-00	METAL CHIP	470 5% 1/10W
R59	1-216-077-00	METAL CHIP	15K 5% 1/10W
R60	1-216-057-00	METAL CHIP	2.2K 5% 1/10W
R61	1-216-025-00	METAL GLAZE	100 5% 1/10W
R62	1-216-025-00	METAL CHIP	100 5% 1/10W
R63	1-216-081-00	METAL CHIP	22K 5% 1/10W
R64	1-216-073-00	METAL CHIP	10K 5% 1/10W
R72	1-216-089-00	METAL GLAZE	47K 5% 1/10W
R77	1-216-033-00	METAL CHIP	220 5% 1/10W
R90	1-216-025-00	METAL GLAZE	100 5% 1/10W
R101	1-216-071-00	METAL CHIP	8.2K 5% 1/10W
R103	1-216-023-00	METAL CHIP	82 5% 1/10W
R104	1-216-069-00	METAL CHIP	6.8K 5% 1/10W
R105	1-216-065-00	METAL CHIP	4.7K 5% 1/10W
R106	1-216-049-00	METAL GLAZE	1K 5% 1/10W
R107	1-216-079-00	METAL CHIP	18K 5% 1/10W
R109	1-216-049-00	METAL GLAZE	1K 5% 1/10W
R110	1-216-059-00	METAL CHIP	2.7K 5% 1/10W
R111	1-216-037-00	METAL GLAZE	330 5% 1/10W
R112	1-216-063-91	METAL GLAZE	3.9K 5% 1/10W
R113	1-216-067-00	METAL CHIP	5.6K 5% 1/10W
R114	1-216-089-00	METAL GLAZE	47K 5% 1/10W
R115	1-216-067-00	METAL CHIP	5.6K 5% 1/10W
R116	1-216-089-00	METAL GLAZE	47K 5% 1/10W
R118	1-216-059-00	METAL CHIP	2.7K 5% 1/10W
R119	1-216-073-00	METAL CHIP	10K 5% 1/10W
R120	1-216-065-00	METAL CHIP	4.7K 5% 1/10W
R121	1-216-073-00	METAL CHIP	10K 5% 1/10W
R122	1-216-065-00	METAL CHIP	4.7K 5% 1/10W
R123	1-216-057-00	METAL CHIP	2.2K 5% 1/10W
R124	1-216-065-00	METAL GLAZE	4.7K 5% 1/10W
R125	1-216-049-00	METAL GLAZE	1K 5% 1/10W
R126	1-216-049-00	METAL GLAZE	1K 5% 1/10W
R127	1-216-081-00	METAL CHIP	22K 5% 1/10W
R128	1-216-031-00	METAL CHIP	180 5% 1/10W
R129	1-216-081-00	METAL CHIP	22K 5% 1/10W
R130	1-216-308-00	METAL CHIP	4.7 5% 1/10W
R131	1-216-308-00	METAL CHIP	4.7 5% 1/10W
R132	1-216-049-00	METAL GLAZE	1K 5% 1/10W
R133	1-216-065-00	METAL CHIP	4.7K 5% 1/10W
R134	1-216-073-00	METAL CHIP	10K 5% 1/10W
R135	1-216-033-00	METAL CHIP	220 5% 1/10W
R136	1-216-073-00	METAL CHIP	10K 5% 1/10W
R137	1-216-009-00	METAL CHIP	22 5% 1/10W

Ref. No.	Part No.	Description	Remark
R138	1-216-089-00	METAL GLAZE	47K 5% 1/10W
R139	1-216-073-00	METAL CHIP	10K 5% 1/10W
R140	1-216-073-00	METAL CHIP	10K 5% 1/10W
R141	1-216-067-00	METAL CHIP	5.6K 5% 1/10W
R143	1-216-081-00	METAL CHIP	22K 5% 1/10W
R145	1-216-073-00	METAL CHIP	10K 5% 1/10W
R146	1-216-295-00	CONDUCTOR, CHIP	(2012)
R149	1-216-689-11	METAL CHIP	39K 5% 1/10W
R150	1-216-113-00	METAL CHIP	470K 5% 1/10W
R151	1-216-049-00	METAL GLAZE	1K 5% 1/10W
R152	1-216-081-00	METAL CHIP	22K 5% 1/10W
R154	1-216-097-00	METAL GLAZE	100K 5% 1/10W
R155	1-216-009-00	METAL CHIP	22 5% 1/10W
R156	1-216-061-00	METAL CHIP	3.3K 5% 1/10W
R157	1-216-113-00	METAL CHIP	470K 5% 1/10W
R201	1-216-071-00	METAL CHIP	8.2K 5% 1/10W
R203	1-216-023-00	METAL CHIP	82 5% 1/10W
R204	1-216-069-00	METAL CHIP	6.8K 5% 1/10W
R205	1-216-065-00	METAL CHIP	4.7K 5% 1/10W
R206	1-216-049-00	METAL GLAZE	1K 5% 1/10W
R207	1-216-079-00	METAL CHIP	18K 5% 1/10W
R209	1-216-049-00	METAL GLAZE	1K 5% 1/10W
R210	1-216-059-00	METAL CHIP	2.7K 5% 1/10W
R211	1-216-037-00	METAL GLAZE	330 5% 1/10W
R212	1-216-063-91	METAL GLAZE	3.9K 5% 1/10W
R213	1-216-067-00	METAL CHIP	5.6K 5% 1/10W
R214	1-216-089-00	METAL GLAZE	47K 5% 1/10W
R215	1-216-067-00	METAL CHIP	5.6K 5% 1/10W
R216	1-216-089-00	METAL GLAZE	47K 5% 1/10W
R218	1-216-059-00	METAL CHIP	2.7K 5% 1/10W
R219	1-216-073-00	METAL CHIP	10K 5% 1/10W
R220	1-216-065-00	METAL CHIP	4.7K 5% 1/10W
R221	1-216-073-00	METAL CHIP	10K 5% 1/10W
R222	1-216-065-00	METAL CHIP	4.7K 5% 1/10W
R223	1-216-057-00	METAL CHIP	2.2K 5% 1/10W
R224	1-216-065-00	METAL GLAZE	4.7K 5% 1/10W
R225	1-216-049-00	METAL GLAZE	1K 5% 1/10W
R226	1-216-049-00	METAL GLAZE	1K 5% 1/10W
R227	1-216-081-00	METAL CHIP	22K 5% 1/10W
R228	1-216-031-00	METAL CHIP	180 5% 1/10W
R229	1-216-081-00	METAL CHIP	22K 5% 1/10W
R230	1-216-308-00	METAL CHIP	4.7 5% 1/10W
R231	1-216-308-00	METAL CHIP	4.7 5% 1/10W
R232	1-216-049-00	METAL GLAZE	1K 5% 1/10W
R233	1-216-065-00	METAL CHIP	4.7K 5% 1/10W
R234	1-216-073-00	METAL CHIP	10K 5% 1/10W
R235	1-216-033-00	METAL CHIP	220 5% 1/10W
R236	1-216-073-00	METAL CHIP	10K 5% 1/10W

**MAIN**

**POWER**

Ref. No.	Part No.	Description	Remark		
R237	1-216-009-00	METAL GLAZE	22	5%	1/10W
R238	1-216-089-00	METAL GLAZE	47K	5%	1/10W
R239	1-216-073-00	METAL CHIP	10K	5%	1/10W
R240	1-216-073-00	METAL CHIP	10K	5%	1/10W
R241	1-216-067-00	METAL CHIP	5.6K	5%	1/10W
R243	1-216-081-00	METAL CHIP	22K	5%	1/10W
R245	1-216-073-00	METAL CHIP	10K	5%	1/10W
R246	1-216-295-00	CONDUCTOR, CHIP			(2012)
R249	1-216-689-11	METAL CHIP	39K	5%	1/10W
R250	1-216-113-00	METAL CHIP	470K	5%	1/10W
R251	1-216-049-00	METAL GLAZE	1K	5%	1/10W
R252	1-216-081-00	METAL CHIP	22K	5%	1/10W
R254	1-216-097-00	METAL GLAZE	100K	5%	1/10W
R255	1-216-009-00	METAL CHIP	22	5%	1/10W
R256	1-216-061-00	METAL CHIP	3.3K	5%	1/10W
R257	1-216-113-00	METAL CHIP	470K	5%	1/10W
R301	1-216-065-00	METAL CHIP	4.7K	5%	1/10W
R302	1-216-065-00	METAL CHIP	4.7K	5%	1/10W
R303	1-216-041-00	METAL CHIP	470	5%	1/10W
R304	1-216-033-00	METAL CHIP	220	5%	1/10W
R305	1-216-061-00	METAL CHIP	3.3K	5%	1/10W
R306	1-216-073-00	METAL CHIP	10K	5%	1/10W
R307	1-216-065-00	METAL CHIP	4.7K	5%	1/10W
R308	1-216-065-00	METAL CHIP	4.7K	5%	1/10W
R309	1-216-121-91	METAL GLAZE	1M	5%	1/10W
R310	1-216-061-00	METAL CHIP	3.3K	5%	1/10W
R311	1-216-065-00	METAL CHIP	4.7K	5%	1/10W
R312	1-216-061-00	METAL CHIP	3.3K	5%	1/10W
R313	1-216-037-00	METAL CHIP	330	5%	1/10W
R314	1-216-085-00	METAL CHIP	33K	5%	1/10W
R315	1-216-073-00	METAL CHIP	10K	5%	1/10W
R316	1-216-057-00	METAL CHIP	2.2K	5%	1/10W
R317	1-216-001-00	METAL CHIP	10	5%	1/10W
R318	1-216-009-00	METAL CHIP	22	5%	1/10W
R319	1-216-031-00	METAL CHIP	180	5%	1/10W
R320	1-216-091-00	METAL CHIP	56K	5%	1/10W
R321	1-216-091-00	METAL CHIP	56K	5%	1/10W
R322	1-216-308-00	METAL CHIP	4.7	5%	1/10W
R324	1-216-049-00	METAL GLAZE	1K	5%	1/10W
R325	1-216-049-00	METAL GLAZE	1K	5%	1/10W
R326	1-216-017-00	METAL GLAZE	47	5%	1/10W
R327	1-216-025-00	METAL GLAZE	100	5%	1/10W
R329	1-216-121-91	METAL GLAZE	1M	5%	1/10W
R331	1-216-073-00	METAL GLAZE	10K	5%	1/10W
R332	1-216-049-00	METAL GLAZE	1K	5%	1/10W
R333	1-216-113-00	METAL CHIP	470K	5%	1/10W
R337	1-216-065-00	METAL CHIP	4.7K	5%	1/10W
R338	1-216-057-00	METAL CHIP	2.2K	5%	1/10W

Ref. No.	Part No.	Description	Remark		
R341	1-216-073-00	METAL CHIP	10K	5%	1/10W
R346	1-216-089-00	METAL GLAZE	47K	5%	1/10W
R347	1-216-037-00	METAL CHIP	330	5%	1/10W
R349	1-216-097-00	METAL GLAZE	100K	5%	1/10W
R350	1-216-061-00	METAL CHIP	3.3K	5%	1/10W
R351	1-216-065-00	METAL CHIP	4.7K	5%	1/10W
R352	1-216-051-00	METAL CHIP	1.2K	5%	1/10W
R353	1-216-089-00	METAL GLAZE	47K	5%	1/10W
R354	1-216-045-00	METAL CHIP	680	5%	1/10W
R355	1-216-037-00	METAL CHIP	330	5%	1/10W
R359	1-216-097-00	METAL GLAZE	100K	5%	1/10W
R360	1-216-097-00	METAL GLAZE	100K	5%	1/10W
R362	1-216-081-00	METAL CHIP	22K	5%	1/10W
R363	1-216-049-00	METAL GLAZE	1K	5%	1/10W
R364	1-216-061-00	METAL CHIP	3.3K	5%	1/10W
R365	1-216-061-00	METAL CHIP	3.3K	5%	1/10W
R367	1-216-059-00	METAL CHIP	2.7K	5%	1/10W
R368	1-216-061-00	METAL CHIP	3.3K	5%	1/10W
R371	1-216-049-00	METAL GLAZE	1K	5%	1/10W
R372	1-216-113-00	METAL CHIP	470K	5%	1/10W
R373	1-216-109-00	METAL CHIP	330K	5%	1/10W
R374	1-216-059-00	METAL CHIP	2.7K	5%	1/10W
R375	1-216-057-00	METAL CHIP	2.2K	5%	1/10W
R376	1-216-035-00	METAL CHIP	270	5%	1/10W
R380	1-216-065-00	METAL CHIP	4.7K	5%	1/10W
< TRANSFORMER >					
T301	1-411-980-11	COIL, BIAS OSCILLATION			
< TUNER UNIT >					
* TU1	1-473-650-11	TUNER UNIT			
< VIBRATOR >					
X1	1-760-130-11	VIBRATOR, CRYSTAL (75kHz)			
*****					
*	1-662-588-11	POWER BOARD			
*****					
	1-533-217-31	HOLDER, FUSE			
	1-575-651-21	CORD, POWER			
< CAPACITOR >					
C901	1-161-494-00	CERAMIC	0.022uF		25V
C902	1-161-494-00	CERAMIC	0.022uF		25V
C903	1-161-494-00	CERAMIC	0.022uF		25V
C904	1-161-494-00	CERAMIC	0.022uF		25V
△C905	1-113-924-11	CERAMIC	0.0047uF	20%	250V
C906	1-161-494-00	CERAMIC	0.022uF		25V

The components identified by mark △ or dotted line with mark. △ are critical for safety. Replace only with part number specified.

**POWER**

**REGULATOR**

Ref. No.	Part No.	Description	Remark
C907	1-161-494-00	CERAMIC 0.022uF	25V
C908	1-161-494-00	CERAMIC 0.022uF	25V
< CONNECTOR >			
△CNP901	1-580-230-11	PIN, CONNECTOR (PC BOARD) 2P	
* CNP902	1-564-509-11	PLUG, CONNECTOR 6P	
< DIODE >			
D901	8-719-046-07	DIODE 2A02M	
D902	8-719-046-07	DIODE 2A02M	
D903	8-719-046-07	DIODE 2A02M	
D904	8-719-046-07	DIODE 2A02M	
D905	8-719-046-07	DIODE 2A02M	
D906	8-719-046-07	DIODE 2A02M	
< FUSE >			
△F901	1-532-500-31	FUSE, TIME-LAG (630mA 250V)	
△F902	1-532-502-31	FUSE, TIME-LAG (1.25A 250V)	
< LINE FILTER >			
△LF901	1-424-485-11	FILTER, LINE	
< SWITCH >			
△SW902	1-762-509-11	SWITCH, POWER (MAIN POWER)	
< TRANSFORMER >			
△T901	1-429-859-11	TRANSFORMER, POWER	
*****			
*	1-662-584-11	REGULATOR BOARD	
*****			
< CAPACITOR >			
C324	1-163-038-00	CERAMIC CHIP 0.1uF	25V
C372	1-163-038-00	CERAMIC CHIP 0.1uF	25V
C373	1-163-038-00	CERAMIC CHIP 0.1uF	25V
C391	1-163-038-00	CERAMIC CHIP 0.1uF	25V
< CONNECTOR >			
CNP312	1-580-158-11	PIN, CONNECTOR 6P	
< DIODE >			
D329	8-719-987-63	DIODE 1N4148M	
D334	8-719-987-63	DIODE 1N4148M	

Ref. No.	Part No.	Description	Remark
< IC >			
IC308	8-759-332-39	IC UPC24M06HF	
IC312	8-759-231-58	IC TA7812S	
*****			
MISCELLANEOUS			
*****			
△5	1-575-651-21	CORD, POWER	
59	1-775-835-11	WIRE, PARALLEL (FFC) (10 CORE)	
62	1-775-834-11	WIRE, PARALLEL (FFC) (22 CORE)	
102	1-452-732-11	MAGNET	
113	1-769-824-11	WIRE (FLAT TYPE) (16 CORE)	
△251	8-848-376-01	OPTICAL PICK-UP KSS-213B	
HE101	1-543-673-11	HEAD, MAGNETIC (ERASE)	
HRP101	1-543-424-21	HEAD (RECORD/PLAYBACK)	
M601	X-3372-674-1	MOTOR ASSY (REEL/CAPSTAN)	
M701	X-2625-769-1	GEAR ASSY (MB), MOTOR (SLED)	
M702	X-2625-770-1	CHASSIS ASSY (MB) (RP), MOTOR (SPINDLE)	
S601	1-571-556-11	SWITCH, LEAF (PLAY)	
S602	1-692-302-11	SWITCH, LEAF (OrO2)	
S603	1-571-556-11	SWITCH, LEAF (REC)	
S604	1-571-556-11	SWITCH, LEAF (MOTOR)	
S701	1-692-960-11	SWITCH, PUSH (1 KEY) (CD DOOR OPEN/CLOSE)	
△T901	1-429-859-11	TRANSFORMER, POWER	
*****			
*****			
HARDWARE LIST			
*****			
#1	7-685-247-19	SCREW +KTP 3X10 TYPE2 NON-SLIT	
#2	7-682-249-09	SCREW +K 3X10	
#3	7-682-560-04	SCREW +BVTT 4X6 (S)	
#4	7-621-770-XX	SCREW +P 2.6X8	
#5	7-685-647-79	SCREW +BVTP 3X10 TYPE2 N-S	
#6	7-685-862-09	SCREW +BVTT 2.6X6 (S)	
#7	7-685-646-79	SCREW +BVTP 3X8 TYPE2 N-S	
#8	7-628-254-05	SCREW +PS 2.6X5	
#9	7-685-861-01	SCREW +BVTT 2.6X5 (S)	
#10	7-685-104-19	SCREW +P 2X6 TYPE2 NON-SLIT	
#11	7-621-255-15	SCREW +P 2X3	
#12	7-685-881-01	SCREW (4X8)	
*****			

The components identified by mark △ or dotted line with mark △ are critical for safety. Replace only with part number specified.

<u>Ref. No.</u>	<u>Part No.</u>	<u>Description</u>	<u>Remark</u>
-----------------	-----------------	--------------------	---------------

ACCESSORIES & PACKING MATERIALS

\*\*\*\*\*

	1-501-594-11	ANTENNA (FM)	
	1-501-843-11	ANTENNA, AM LOOP	
	3-800-801-13	MANUAL, INSTRUCTION (ENGLISH, GERMAN) (AEP)	
	3-800-801-23	MANUAL, INSTRUCTION (FRENCH, SPANISH) (AEP)	
	3-800-801-33	MANUAL, INSTRUCTION (DUTCH, SWEDISH, PORTUGUESE) (AEP)	
	3-800-801-43	MANUAL, INSTRUCTION (ITALIAN) (Italian)	
*	3-939-550-01	INDIVIDUAL CARTON	
	4-973-399-01	LID, BATTERY CASE (for RMT-C202)	
	8-917-525-90	REMOTE COMMANDER RMT-C202 SET	