

PMC-303L

SERVICE MANUAL

AEP Model
UK Model



Dolby noise reduction manufactured under license from Dolby Laboratories Licensing Corporation.

"DOLBY" and the double-D symbol \square are trademarks of Dolby Laboratories Licensing Corporation.

Model Name Using Similar Mechanism	CD Section	CFD-17
	Tape Section	PMC-301
Optical Pick-up Type	KSM-213BAN/S-N	
Tape Transport Mechanism Type	MF-303-105	

SPECIFICATIONS

CD player section

System

Compact disc digital audio system

Laser diode properties

Material: GaAlAs

Wave length: 780 nm

Emission duration: Continuous

Laser output: Less than 44.6 μ W (This output is the value measured at a distance of about 200 mm from the objective lens surface on the optical pick-up block with 7 mm aperture.)

Spindle speed

200 r/min (rpm) to 500 r/min (rpm) (CLV)

Number of channels

2

Frequency response

20 - 20,000 Hz +1/-2 dB

Wow and flutter

Below measurable limit

Radio section

Frequency range

FM	AEP, UK, German model : 87.6 - 107 MHz Italian model : 87.5 - 108 MHz
MW	531 - 1,602 kHz
LW	153 - 279 kHz

IF

FM: 10.7 MHz
MW/LW: 450 kHz

Aerials

FM: FM lead aerial
MW/LW: External aerial terminals

Cassette-corder section

Recording system

4-track 2 channel stereo

Fast winding time

Approx. 120s (sec.) with Sony cassette C-60

Frequency response

TYPE I (normal): 40 - 16,000 Hz
TYPE II (high position): 40 - 17,000 Hz

General

Speaker

Full range: 10 cm (4 in.) dia., cone type x 2

Outputs

Headphones jack (stereo minijack)

For 16 - 68 ohms impedance headphones

Maximum power output

20 W + 20 W

- Continued on page 2 -

PERSONAL COMPONENT SYSTEM
SONY[®]



Power requirements

For personal component system:

UK model

230 -240 V AC, 50 Hz

AEP, German, Italian model

220 - 230 V AC, 50 Hz

For remote commander:

3 V DC, 2 R6 (size AA) batteries

Power consumption

AC 40 W

Dimensions (incl. projecting parts)

Unit: approx. 140 × 222.5 × 280.5 mm (w/h/d)

(5 7/8 × 8 7/8 × 11 1/4 inches)

Speaker: approx. 130 × 222.5 × 210 mm (w/h/d)

(5 1/8 × 8 7/8 × 8 3/8 inches)

Mass (incl. batteries)

Unit: approx. 3.5 kg (7 lb. 11 oz)

Speaker: approx. 1.4 kg (3 lb. 1 oz)

Supplied accessories

Remote (1)

FM aerial (1)

MW/LW loop aerial (1)

Design and specifications are subject to change without notice.

CAUTION

Use of controls or adjustments or performance of procedures other than those specified herein may result in hazardous radiation exposure.

Laser component in this product is capable of emitting radiation exceeding the limit for Class 1.

For customers in Europe and Saudi Arabia

CLASS 1 LASER PRODUCT
LUOKAN 1 LASERLAITE
KLASS1 LASERAPPARAT

This Compact Disc player is classified as a CLASS 1 LASER product. The CLASS 1 LASER PRODUCT label is located on the rear exterior.

Flexible Circuit Board Repairing

- Keep the temperature of the soldering iron around 270°C during repairing.
- Do not touch the soldering iron on the same conductor of the circuit board (within 3 times).
- Be careful not to apply force on the conductor when soldering or unsoldering.



Notes on chip component replacement

- Never reuse a disconnected chip component.
- Notice that the minus side of a tantalum capacitor may be damaged by heat.

TABLE OF CONTENTS

Specifications	1
1. SERVICING NOTES	3
2. GENERAL	
Location and Function of Controls	4
3. DISASSEMBLY	
3-1. Rear Plate Removal	6
3-2. Cabinet (Upper) Removal	6
3-3. Front Panel Removal	7
3-4. MD Section Removal	7
3-5. Heat Sink, Diode Board, VOL Board Removal	8
3-6. Main Board, Power Board Removal	8
4. TEST MODE	9
5. ADJUSTMENTS	
5-1. Mechanical Adjustments	11
5-2. Electrical Adjustments	12
6. EXPLANATION OF IC TERMINALS	20
7. DIAGRAMS	
7-1. Block Diagram (Main Section)	22
7-2. Block Diagram (CD Section)	25
7-3. Printed Wiring Boards (Main Section)	29
7-4. Schematic Diagram (Main Section)	31
7-5. Schematic Diagram (TC Section)	36
7-6. Printed Wiring Boards (TC Section)	39
7-7. Printed Wiring Boards (CD Section)	41
7-8. Schematic Diagram (CD Section)	43
7-9. Printed Wiring Boards (Display Section)	46
7-10. Schematic Diagram (Display Section)	49
8. EXPLODED VIEWS	
8-1. Chassis Section	57
8-2. Front Panel Section	58
8-3. Cabinet (Upper) Section	59
8-4. Mechanism Deck Section (1)	60
8-5. Mechanism Deck Section (2)	61
8-6. Optical Pick-up Section	62
8-7. Speaker Section	63
9. ELECTRICAL PARTS LIST	64

SAFETY-RELATED COMPONENT WARNING!!

COMPONENTS IDENTIFIED BY MARK  OR DOTTED LINE WITH MARK  ON THE SCHEMATIC DIAGRAMS AND IN THE PARTS LIST ARE CRITICAL TO SAFE OPERATION. REPLACE THESE COMPONENTS WITH SONY PARTS WHOSE PART NUMBERS APPEAR AS SHOWN IN THIS MANUAL OR IN SUPPLEMENTS PUBLISHED BY SONY.

SECTION 1 SERVICING NOTES

NOTES ON HANDLING THE OPTICAL PICK-UP BLOCK OR BASE UNIT

The laser diode in the optical pick-up block may suffer electrostatic break down because of the potential difference generated by the charged electrostatic load, etc. on clothing and the human body. During repair, pay attention to electrostatic break down and also use the procedure in the printed matter which is included in the repair parts. The flexible board is easily damaged and should be handled with care.

NOTES ON LASER DIODE EMISSION CHECK

The laser beam on this model is concentrated so as to be focused on the disc reflective surface by the objective lens in the optical pick-up block. Therefore, when checking the laser diode emission, observe more than 30cm away from the objective lens.

CHUCK PLATE JIG ON REPAIRING

On repairing CD section, playing a disc without the CD lid, use Chuck Plate Jig.

- Code number of Chuck Plate Jig : X-4918-255-1

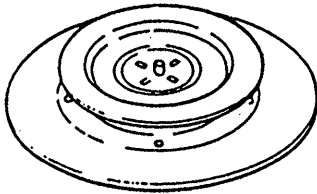

LASER DIODE AND FOCUS SEARCH OPERATION CHECK

1. Open the lid for CD.
2. Push on LEAF SWITCH (S702) as following figure.
3. Press  key.
4. Confirm the laser diode emission while observing the objecting lens. When there is no emission, Auto Power Control circuit or Optical Pick-up is broken. Objective lens moves up and down once for the focus search.

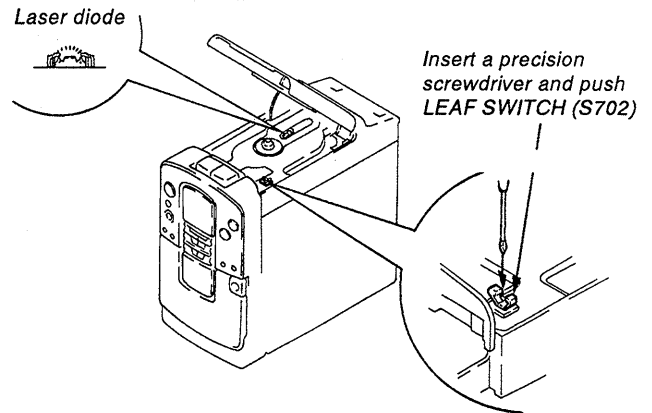

SECTION 2 GENERAL

LOCATION AND FUNCTION OF CONTROLS

Front Panel

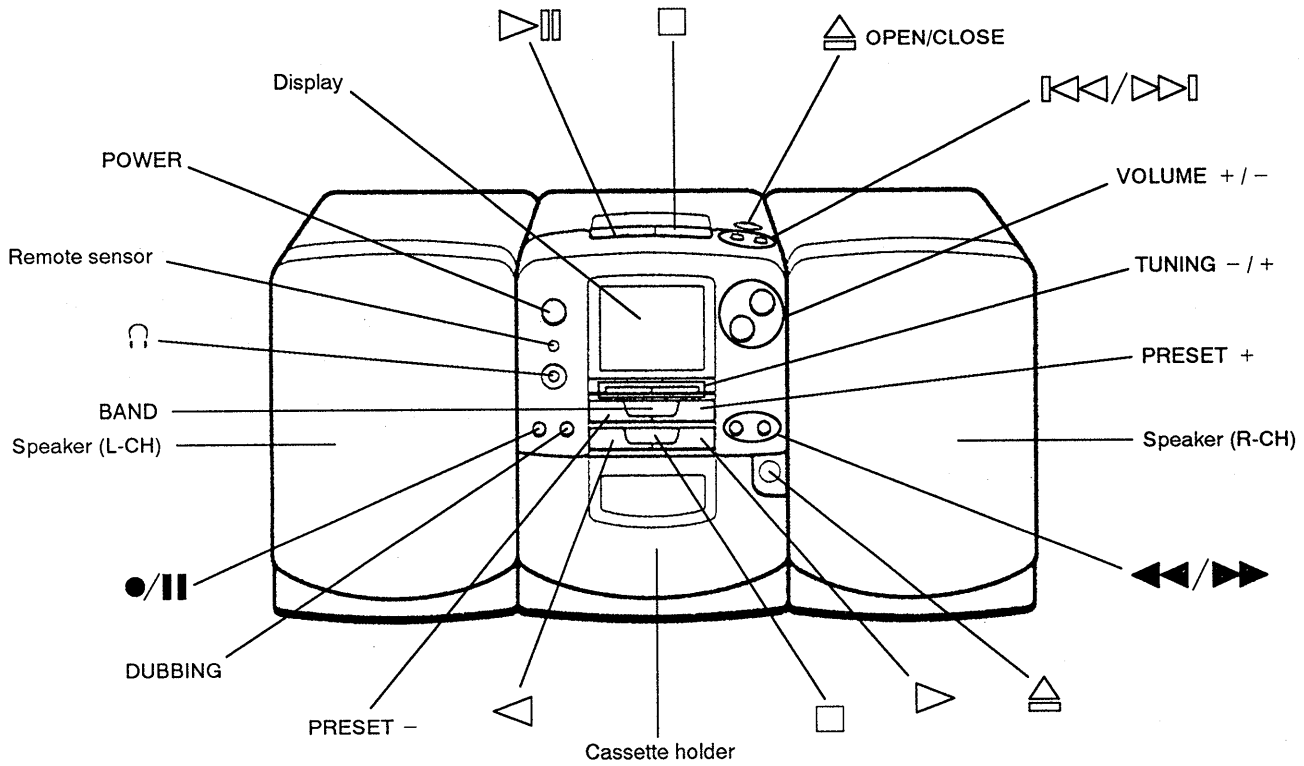

Remote Commander (RMT-C303A)

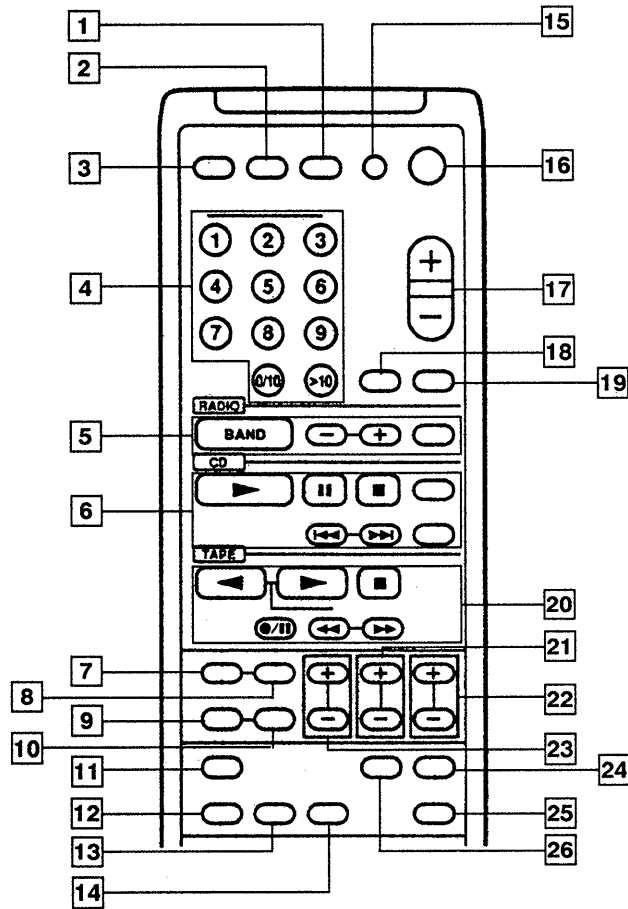

- | | |
|--------------------------------|----------------------------------|
| 1 SLEEP button | 14 COUNTER RESET button |
| 2 BEEP button | 15 CLOCK button |
| 3 DISPLAY button | 16 POWER button |
| 4 Numeric buttons | 17 VOLUME +, - buttons |
| 5 Tuner control buttons | 18 SOUND button |
| 6 CD control buttons | 19 MEGA BASS button |
| 7 ALARM button | 20 TAPE control buttons |
| 8 ALARM SET/OFF button | 21 HOUR +, - buttons |
| 9 TIMER button | 22 MIN +, - buttons |
| 10 TIMER SET/OFF button | 23 SELECT +, - buttons |
| 11 FUNCTION button | 24 ENTER button |
| 12 DOLBY NR button | 25 STEREO/MONO/ISS button |
| 13 DIR MODE button | 26 CANCEL button |

SECTION 3 DISASSEMBLY

Note : Follow the disassembly procedure in the numerical order given.

3-1. REAR PLATE REMOVAL

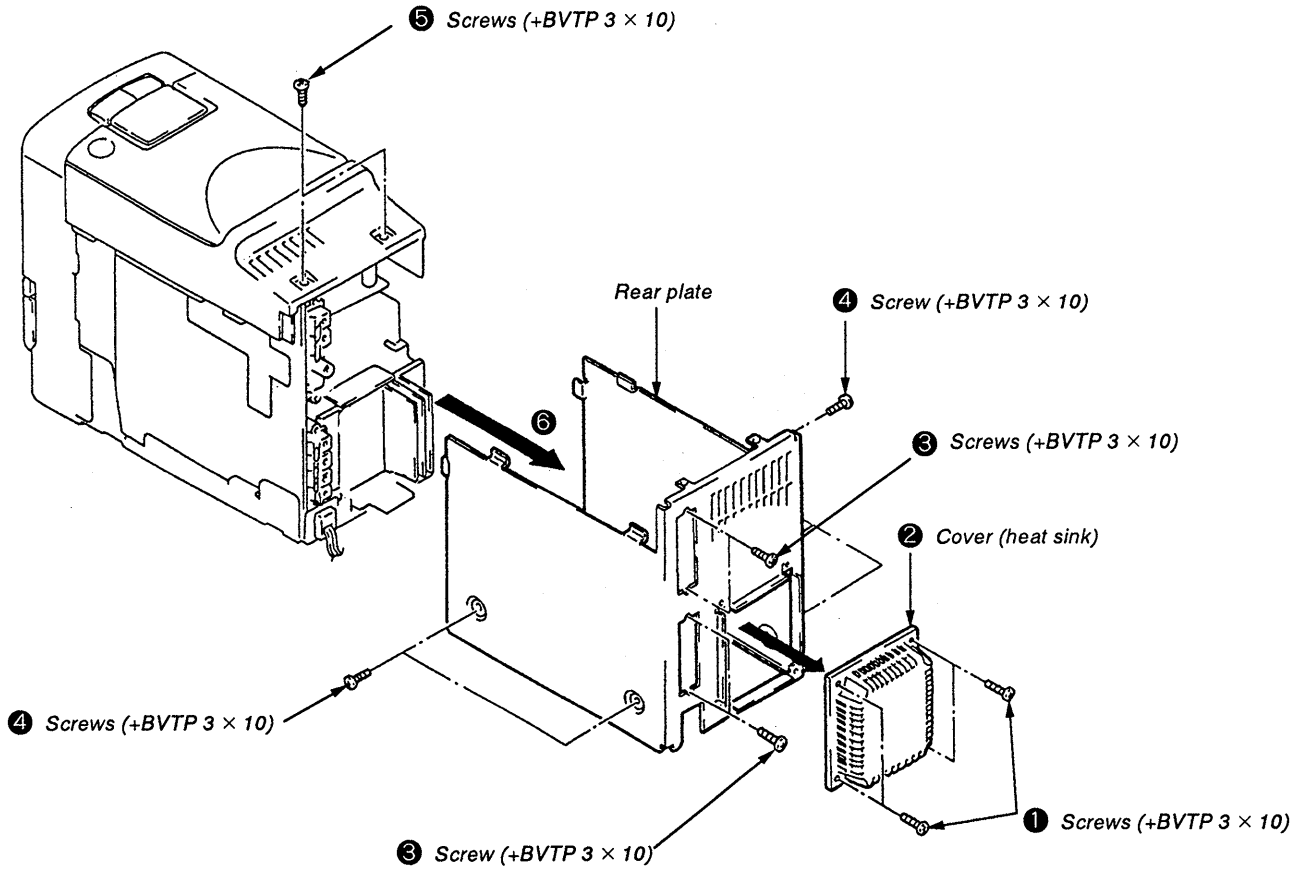

3-2. CABINET (UPPER) REMOVAL

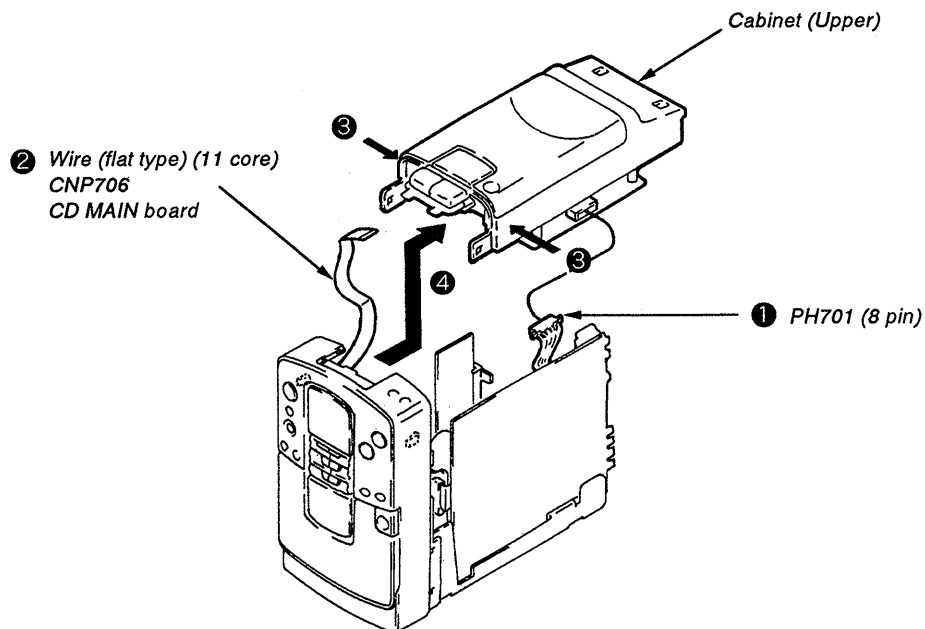

3-3. FRONT PANEL REMOVAL

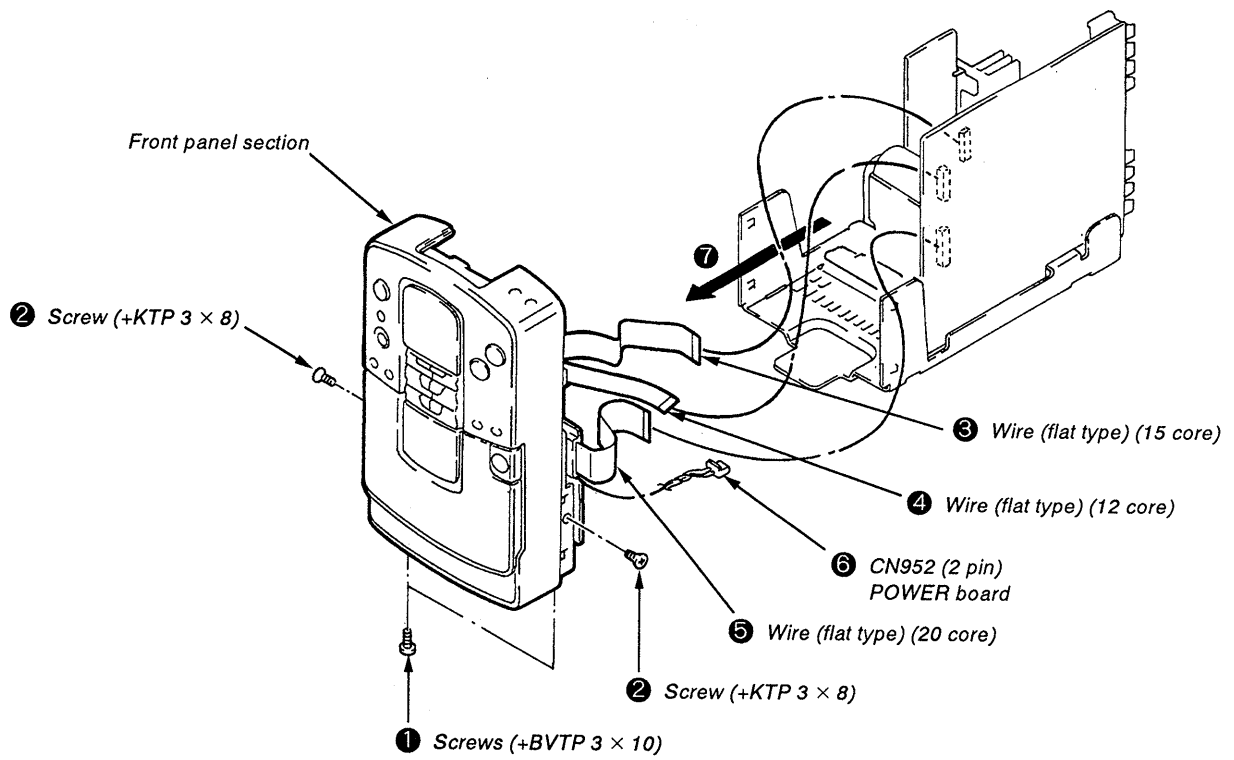

3-4. MD SECTION REMOVAL (MF-303-105)

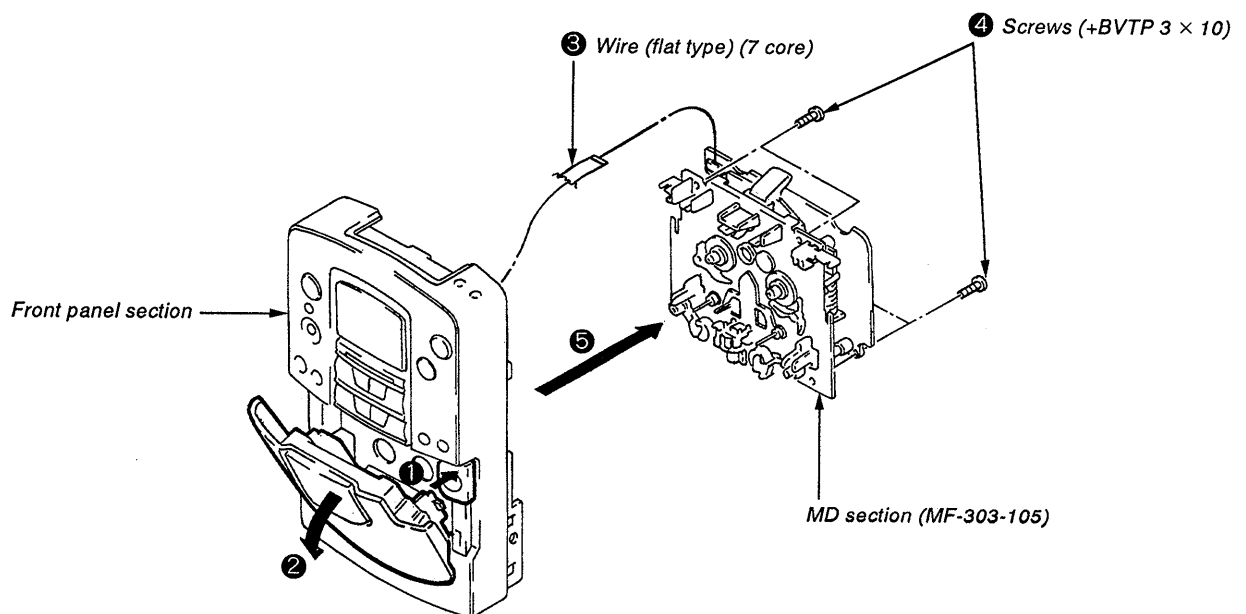

3-5. HEAT SINK, DIODE BOARD, VOL BOARD REMOVAL

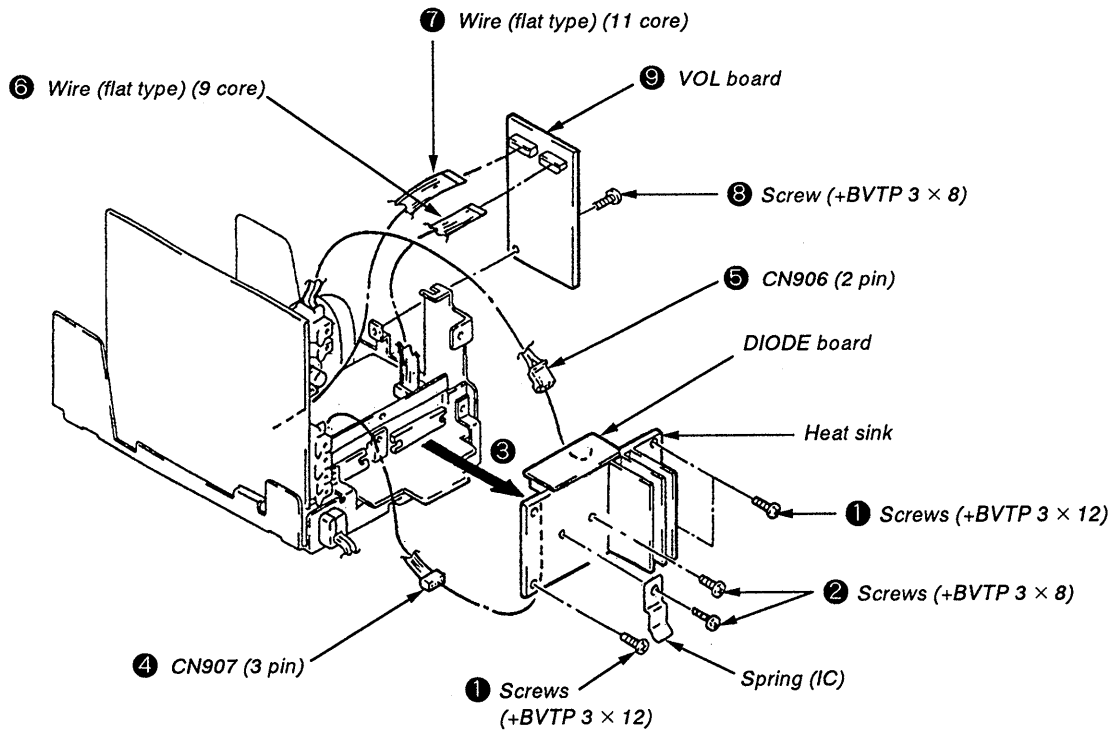

3-6. MAIN BOARD, POWER BOARD REMOVAL

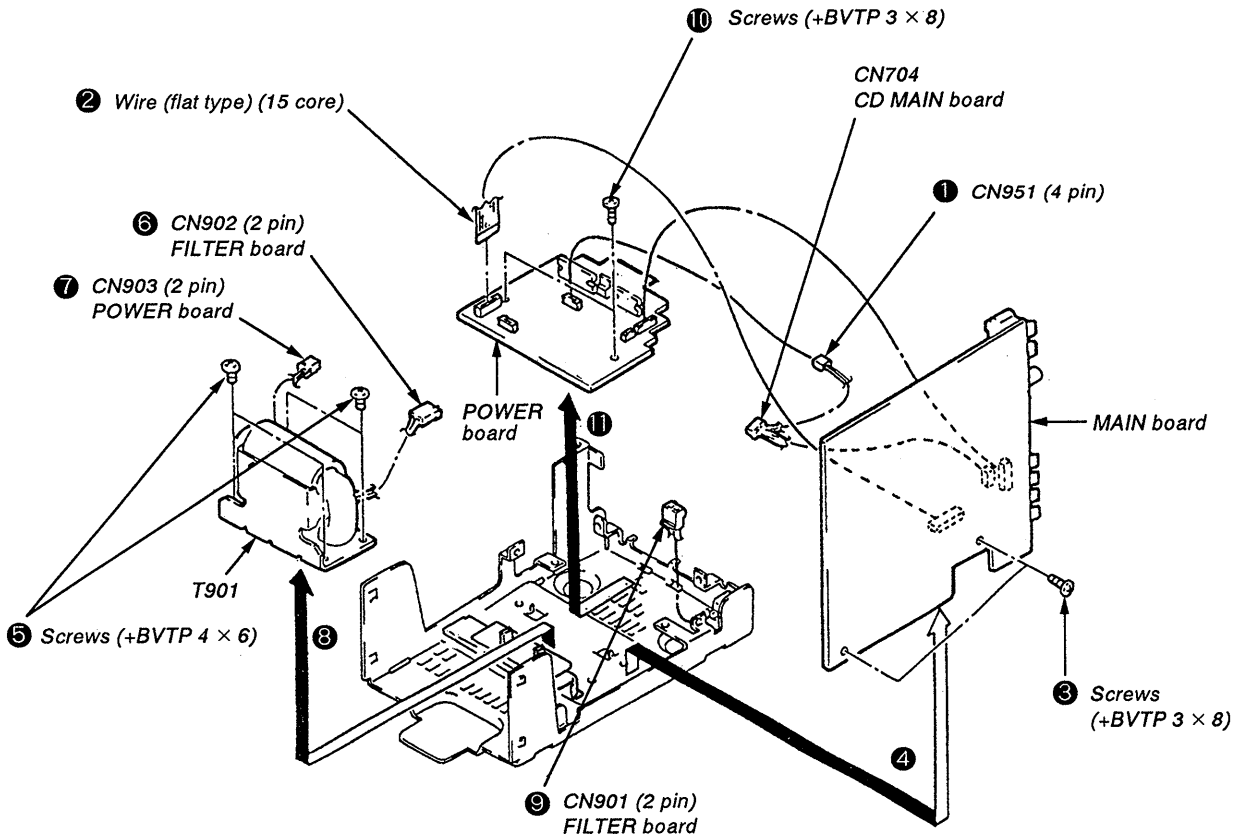

SECTION 4 TEST MODE

< Entering test mode >

- With the power off, while holding down the DUBBING key and the TUNING + key, press the POWER key. The display is normal display. (Pre-test mode)

In this state,

- 1) Press the CD STOP key The system goes into CD test mode.
 - 2) Press the DUBBING key The system goes into display test mode.
- * In display test mode, pressing the DUBBING key repeatedly switches all the COM indicators OFF and ON.

< Ending test mode >

- With the system in pre-test mode, pressing any key other than the CD STOP key or DUBBING key ends test mode.
- Test mode in ended by switching the power OFF or by switching the function.

< Display test mode usage method >

- (1) Immediately after entering test mode, the indicators are all OFF. Then, when the DUBBING key is pressed, the display follows the pattern sequence below.

- 1) All OFF ←
 - 2) COM 0 all ON
 - 3) COM 1 all ON
 - 4) COM 2 all ON
 - 5) COM 3 all ON
 - 6) All ON
-

< CD test mode definitions >

Mode	CD state	LCD display
STOP	All stopped : initial state.	See *
PLAY	Playback with E-F balance and tracking gain \$37 and \$3F, respectively ; All servo ON	PL 7 F
FOCUS	The E-F balance and tracking gain are set to \$37 and \$3F, respectively. The focus search is repeated. If there is a disc and the focus servo is on, rotation with CLV-S starts. Focus servo ON, CLV-S, tracking servo OFF, sled servo OFF.	Cd F
TRACKING Gain UP	Tracking gain up with servo ON.	Cd guP
FF SLED	SLED sent to outer edge.	Cd - F
FR SLED	SLED sent to inner edge.	Cd - r
FOCUS FF	SLED sent to outer edge with focus servo ON.	Cd - F F
FOCUS FR	SLED sent to inner edge with focus servo ON.	Cd - F r
HI PLAY	High-speed playback with E-F balance and tracking gain \$37 and \$3F, respectively ; All servo ON	HP 7 F

* COM0 → COM1 → COM2 → COM3 → All lit repeated ; One second per step

< CD test mode transition table >

Operation keys



operation key CD state	■	PLAY/ PAUSE	AMS FR		AMS FF		>10
			Continuous press	Releas	Continuous press	Releas	
STOP	STOP	FOCUS	FR SLED	STOP	FF SLED	STOP	STOP
FOCUS	STOP	PLAY	FOCUS FR	FOCUS	FOCUS FF	FOCUS	PLAY
PLAY	STOP	TRACKING Gain UP	FOCUS FR	FOCUS	FOCUS FF	FOCUS	HI PLAY
TRACKING Gain UP	STOP	PLAY	FOCUS FR	FOCUS	FOCUS FF	FOCUS	TRACKING Gain UP
HI PLAY	STOP	PLAY	FOCUS FR	FOCUS	FOCUS FF	FOCUS	HI PLAY

When the tracking gain is up, when the AMS FF/FR, PLAY, or STOP key is pressed, the tracking gain up state must be cleared.
 For Hi play, when the AMS FF/FR, PLAY, or STOP key is pressed, the Hi play state must be cleared.

SECTION 5 ADJUSTMENTS

5-1. MECHANICAL ADJUSTMENTS

PRECAUTION

1. Clean the following parts with a denatured-alcohol-moistened swab :

record/playback/erase head	pinch roller
capstan	rubber belts
2. Demagnetize the record/playback/erase head with a head demagnetizer.
3. Do not use a magnetized screwdriver for the adjustments.
4. After the adjustments, apply suitable locking compound to the parts adjusted.
5. The adjustments should be performed in the order given in this service manual.

Torque Measurement

Torque	Torque Meter	Meter Reading
Forward	CQ-102D	25 – 50g•cm (0.35 – 0.69 oz•inch)
Forward back tension	CQ-102D	2.5 – 5g•cm (0.035 – 0.069 oz•inch)
Reverse	CQ-102RC	25 – 50g•cm (0.35 – 0.69 oz•inch)
Reverse back tension	CQ-102RC	2.5 – 5g•cm (0.035 – 0.069 oz•inch)
Fast Forward	CQ-201B	* 60 – 100g•cm (0.84 – 1.38 oz•inch)

* Before the fast forward torque measurement, the record/playback/erase head is turn to forward mode.

Tape Tension Measurement

Torque	Torque Meter	Meter Reading
Forward	CQ-403A	more than 100g (more than 3.53 oz)
Reverse	CQ-403R	

Head Height Adjustment

Procedure :

1. If one does not have a mirror cassette CQ-009C (8-909-708-01), cut out the three portions of a 90-minute cassette tape shell as indicated below and use that cassette tape.

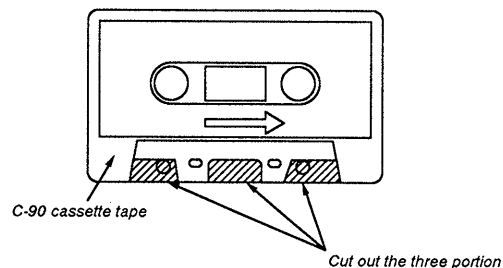

2. Set to the FWD playback mode. Loosen the FWD tape guide fixing screw and adjust with inserting the head height adjustment shim to eliminate tape curl and tape twist in the portions of tape guide and head.
3. Set to the REV playback mode. Loosen the REV tape guide fixing screw and adjust with inserting the head height adjustment shim to eliminate tape curl and tape twist in the portions of tape guide and head.
4. After the adjustments, apply suitable locking compound to the screws (P2 × 8).

Note : Make the assembly do not touch the NR slider for head height adjustment shims.

Adjustment Location :

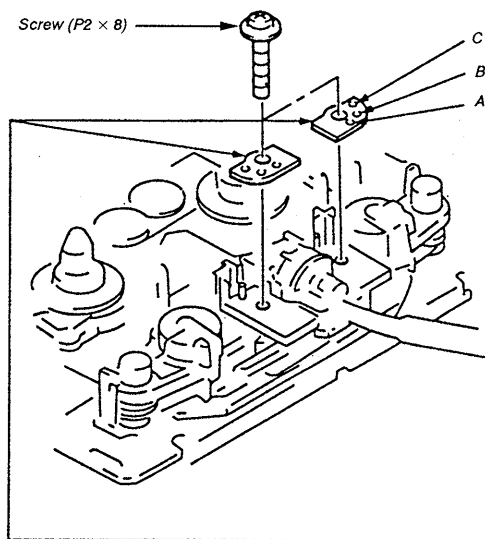

Head height adjustment shims

Part No.	t	Holes
3-384-356-01	0.30 ± 0.02	without
3-384-356-11	0.35 ± 0.02	A
3-384-356-21	0.40 ± 0.02	B
3-384-356-31	0.45 ± 0.02	C
3-384-356-41	0.50 ± 0.02	without

5-2. ELECTRICAL ADJUSTMENTS

DECK SECTION 0dB=0.775V

PRECAUTION

1. The adjustments should be performed in the order given in this service manual. As a rule, adjustments about playback should be performed before those about recording.
2. The adjustments should be performed before for both L-CH and R-CH.
3. Function mode TAPE

Standard Input Level

Input terminal	CD IN
Signal source impedance	1k Ω
Input signal level	0.23V (- 10.7dB)
Frequency	1kHz

Standard Output Level

Output terminal	SP OUT (L, R)	H.P OUT	DOLBY OUT
Load impedance	4 Ω	32 Ω	47k Ω
Output signal level	0.775V (0dB)	77.5mV (- 20dB)	0.18V (- 12.7dB)

Test Tape

Type	Signal	Used for
WS-48A	3kHz, 0dB	tape speed adjustment
P-4-L300	315Hz, 0dB	playback level, record/playback/erase head azimuth and phase adjustments
P-4-A063	6.3kHz, - 10dB	record/playback/erase head azimuth and phase adjustments
CS-123	—	record bias, record level adjustments

Tape Speed Adjustment

Procedure :

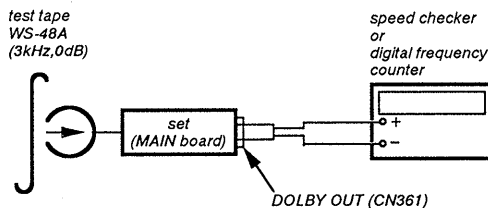

1. Set to the FWD playback mode.
2. Adjust RV601 so that the reading on the digital frequency counter is within the adjustment value below.

Adjustment Value : normal speed

Speed checker	Digital frequency counter
- 0.33 to +0.33%	3,010 to 3,030 Hz

Frequency difference between REV side should be within $\pm 1\%$ (30Hz).

Adjustment Location : TC board (See page18)

Playback Level Adjustment

Procedure :

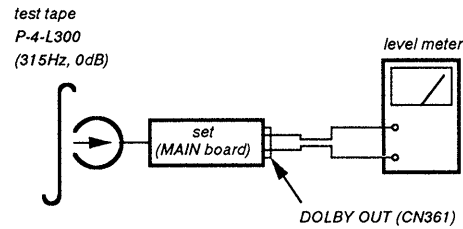

1. Set to the FWD playback mode and adjust RV102 (L-CH) and RV202 (R-CH) so that the reading on the level meter is within the adjustment value below.

Adjustment Value :

DOLBY OUT level : 0.27 to 0.30V (- 9.3 to - 8.3dB)
Level difference between channels : within 0.3dB

Confirm the DOLBY OUT level does not change even if playback or stop operation is repeated several time.

2. Set to the REV playback mode and confirm that the DOLBY OUT level difference between FWD playback mode is within 0.5dB.

Adjustment Location : TC board (See page 18)

Record/Playback/Erase Head Azimuth and Phase Adjustments

Procedure :

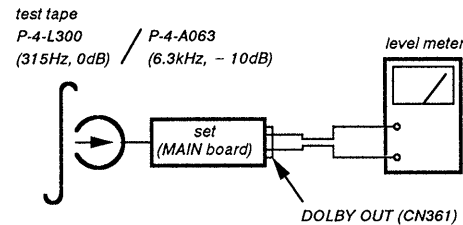

1. Set to the FWD (REV) playback mode with P-4-L300 and reading on level meter.
2. Set to the FWD (REV) playback mode with P-4-A063 and confirm that the reading on the level meter is within $- 12 \pm 2$ dB relative to the P-4-L300 playback level.
3. If the confirmation value are not satisfied, replace the adjustment shims and repeat the steps 1 and 2.

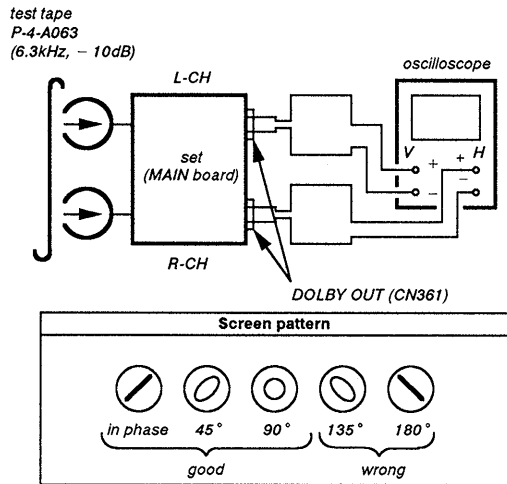

- Set to the FWD (REV) playback mode and confirm that the screen pattern.
- After the adjustment, apply suitable locking compound to the screws (P2 × 8).

Adjustment Location :

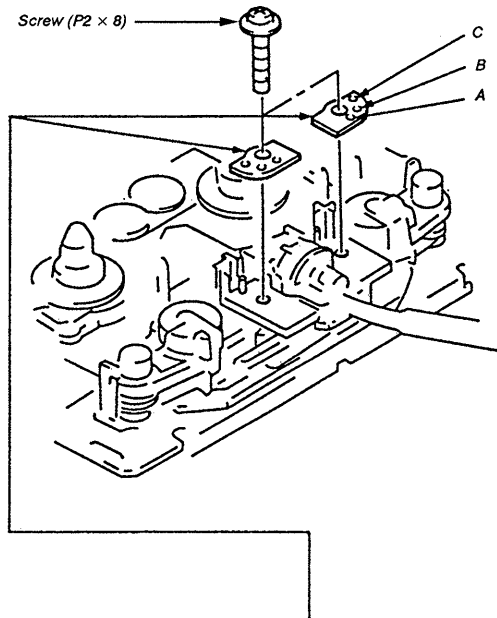

Head height adjustment shims

Part No.	t	Holes
3-384-356-01	0.30 ± 0.02	without
3-384-356-11	0.35 ± 0.02	A
3-384-356-21	0.40 ± 0.02	B
3-384-356-31	0.45 ± 0.02	C
3-384-356-41	0.50 ± 0.02	without

Record Level Adjustment

Procedure :

- Mode : record

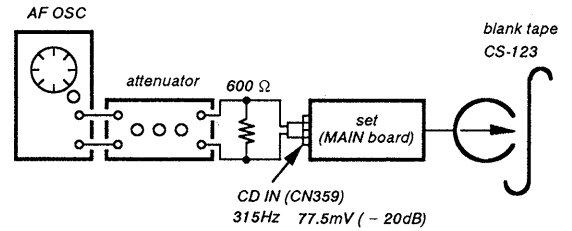

- Mode : FWD Playback

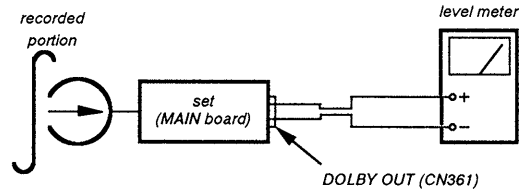

- Confirm that the DOLBY OUT level difference at record and playback is within $0 \pm 0.5\text{dB}$ relative to the DOLBY OUT level, at 315Hz with -20dB inputs from CD IN. If the confirmation value are not satisfied, adjust RV103 (L-CH), RV203 (R-CH) and repeat the steps 1 and 2.
- Confirm that the REV playback mode is within confirmation value.

Adjustment Location : TC board (See page 18)

Record Bias Adjustment

Procedure :

1. Mode : Record

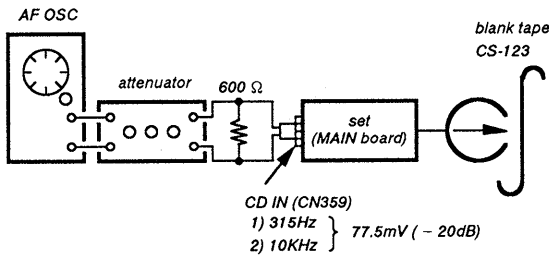

2. Mode : FWD Playback

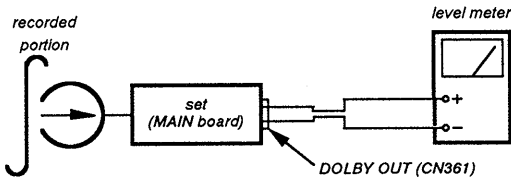

3. Confirm that the DOLBY OUT level difference between 315Hz within -20dB and 10kHz with -20dB is within $0 \pm 1\text{dB}$. If the confirmation value are not satisfied, adjust RV104 (L-CH), RV204 (R-CH) and repeat the steps 1 and 2.
4. Confirm that the REV playback mode is within confirmation value.

Adjustment Location : TC board (See page 18)

TUNER SECTION

Precautions in Repairing

Note : As a FM front-end (TU1) is difficult to repair if faulty, replace it with new one.

● AM Section

BAND switch : MW or LW

VOLUME : MIN

AM RF signal generator

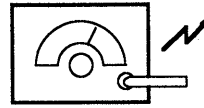

Put the lead-wire antenna close to the set.

30% amplitude modulation by 400Hz signal.
Output level : as low as possible

- Repeat the procedures in each adjustment several times, and the frequency coverage and tracking adjustments should be finally done by the trimmer capacitors.

AM IF ALIGNMENT	
Adjust for a maximum reading on level meter	
CFT1	455kHz

MW TRACKING ADJUSTMENT	
Adjust for a maximum reading on level meter	
L2	620kHz
CT4	1,400kHz

LW TRACKING ADJUSTMENT	
Adjust for a maximum reading on level meter	
L3	160kHz
CT5	260kHz

Adjustment Location : MAIN board (See page 18)

MW/LW Frequency coverage Adjustment

Setting :

BAND switch : MW or LW

VOLUME : as required

[MAIN BOARD] (Conductor side)

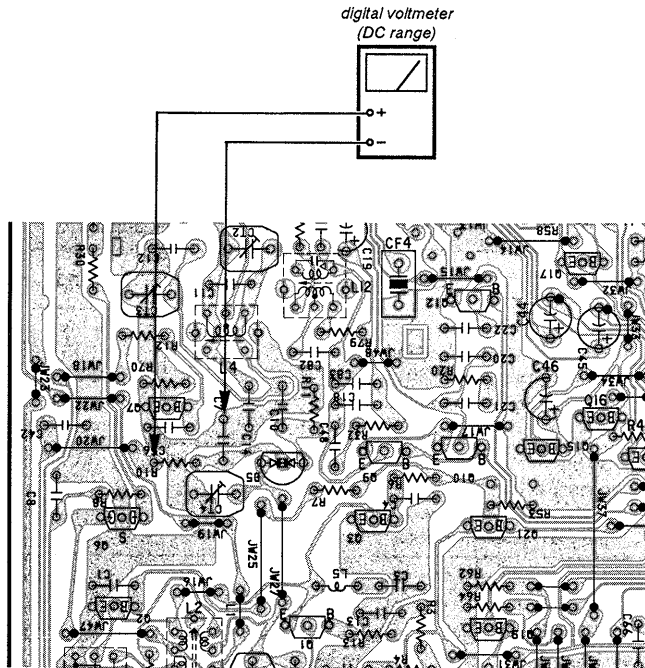

MW FREQUENCY COVERAGE ADJUSTMENT		
Adjustment part	Frequency display	Reading on Digital Voltmeter
L4	531kHz	$0.7 \pm 0.2V$
CT2	1,602kHz	$7.2 \pm 0.5V$

LW FREQUENCY COVERAGE ADJUSTMENT		
Adjustment part	Frequency display	Reading on Digital Voltmeter
(Confirmation)	153kHz	$0.45 \pm 0.1V$
CT3	279kHz	$7.2 \pm 0.5V$

Adjustment Location : MAIN board (See page 18)

CD SECTION

Note on Adjustment

1. Perform adjustment in test mode.
After adjustment, be sure to release test mode.
2. Perform adjustments in the order given.
3. Use the disc (YEDS-18, Part No. 3-702-101-01) only when so indicated.

Before adjustment

Put the set into test mode (See page 9) and perform the following checks.

Repair if there are any problems.

● Sled Motor Check

1. press $\triangleright \square$ key, then press OFF button.
2. Press \blacktriangleright , \blacktriangleleft keys and confirm that the Optical pick-up moves smoothly from the innermost to outermost circumference and back smoothly and with no catching or abnormal noises.
 \blacktriangleright : Optical pick-up moves to the outer circumference
 \blacktriangleleft : Optical pick-up moves to the inner circumference

● Focus Search Check

1. Press $\triangleright \square$ key. (Focus search operation is performed continuously.)
2. Look at the Optical pick-up objective lens and confirm that it moves up and down smoothly, with no catching or abnormal noises.
3. Press \square button.
Confirm that focus search operation stops. If it does not, press \square button again longer.

Note : When the malfunction is occurred by mis-passing other keys, turn off the power and check again from making the test mode.

E-F Balance Adjustment

This adjustment is to be done when the optical block is replaced.

Adjustment procedure :

1. Connect oscilloscope to test point TP (VC) and TP (TEO) on CD MAIN board.
2. Put the set into test mode.
3. Optical pick-up setting to the center by \blacktriangleright or \blacktriangleleft button pushing.
4. Put disc (YEDS-18) in and press the $\triangleright \square$ button.
5. Adjust RV703 so that the oscilloscope traverse waveform is symmetrical, as shown in the figure below.
6. Release test mode after adjustment is completed.

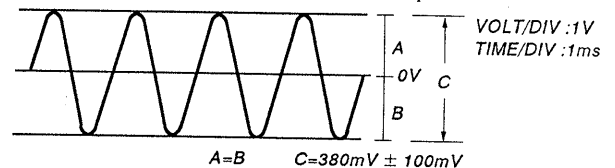

Adjustment Location : CD MAIN board (See page 19)

Focus Bias Adjustment

This adjustment is to be done when the optical block is replaced.

Adjustment procedure :

1. Connect oscilloscope to test point TP (VC) and TP (RFO) on CD MAIN board.
2. Put the set into test mode. (See page 9)
3. Optical pick-up setting to the center by ►► or ◀◀ button pushing.
4. Put disc (YEDS-18) in and press the ► button.
5. Press the ► button. (Tracking servo ON)
6. Adjust RV701 so that the oscilloscope waveform is as shown in the figure below (eye pattern).
A good eye pattern means that the diamond shape (◇) in the center of the waveform can be clearly distinguished.
7. Release test mode after adjustment is completed. (See page 9)

- RF signal reference waveform (eye pattern)

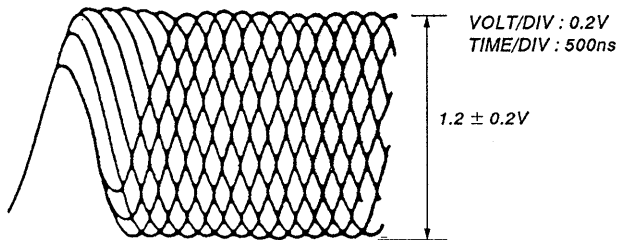

When observing the eye pattern, set the oscilloscope for AC range and raise vertical sensitivity.

[CD MAIN BOARD]

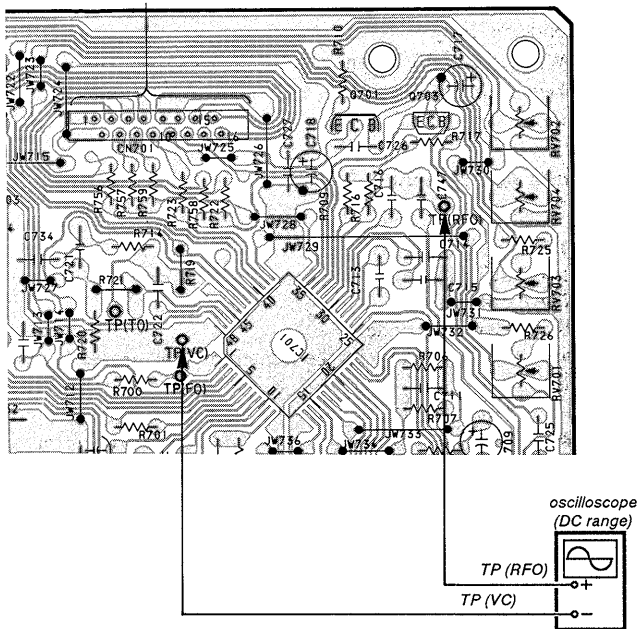

Adjustment Location : CD MAIN board (See page 19)

Focus/Tracking Gain Adjustment

A frequency response analyzer is necessary in order to perform this adjustment exactly.

However, this gain has a margin, so even if it is slightly off, there is no problem. Therefore, do not perform this adjustment.

Focus/tracking gain determines the pick-up follow-up (vertical and horizontal) relative to mechanical noise and mechanical shock when the 2-axis device operate.

However, as these reciprocate, the adjustment is at the point where both are satisfied.

- When gain is raised, the noise when the 2-axis device operates increases.
- When gain is lowered, mechanical shock and skipping occurs more easily.
- When gain adjustment is off, the symptoms below appear.

Symptoms \ Gain	Focus	Tracking
<ul style="list-style-type: none"> • The time until music starts becomes longer for STOP → ► button or automatic selection. (◀◀, ►► buttons pressed.) (Normally takes about 2 seconds.) 	low	low or high
<ul style="list-style-type: none"> • Music does not start and disc continues to rotate for STOP → ► button or automatic selection. (◀◀, ►► buttons pressed.) 	—	low
<ul style="list-style-type: none"> • Sound is interrupted during PLAY. Or time counter display stops progressing. 	—	low
<ul style="list-style-type: none"> • More noise during 2-axis device operation. 	high	high

The following is a simple adjustment method.

— Primary Adjustment —

Note : Since exact adjustment cannot be performed, remember the positions of the controls before performing the adjustment. If the positions after the primary adjustment are only a little different, return the controls to the original position.

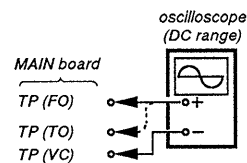

Procedure :

1. Keep the set horizontal.
If the set is not horizontal, this adjustment cannot be performed due to the gravity against the 2-axis device.
2. Insert disc (YEDS-18) and press ► button.
3. Connect oscilloscope to TP(FO) and TP(VC) on CD MAIN board.
4. Adjustment RV702 on digital board so that the waveform is as shown in the figure below. (focus gain adjustment)

VOLT/DIV : 100mV
TIME/DIV : 2mS

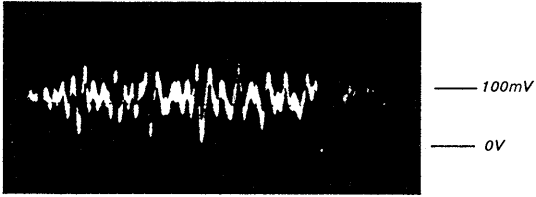

- Inccorret Examples (DC level changes more than on adjusted waveform)

low focus gain

VOLT/DIV : 100mV
TIME/DIV : 2mS

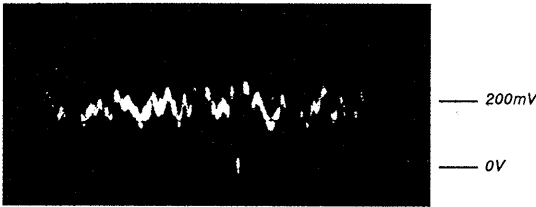

high focus gain

VOLT/DIV : 100mV
TIME/DIV : 2mS

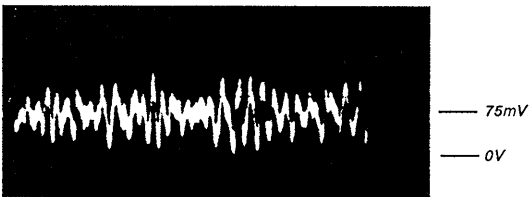

5. Connect oscilloscope to TP(TO) and TP(VC) on CD MAIN board.
6. Adjust RV704 on digital board so that the waveform is as shown in the figure below.

VOLT/DIV : 1V
TIME/DIV : 2mS



- Incorrect Examples (fundamental wave appears)

low tracking gain

VOLT/DIV : 1V
TIME/DIV : 2mS

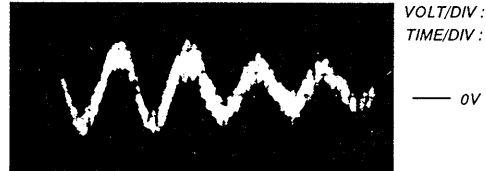

*high tracking gain
(high fundamental wave
than for low gain)*

VOLT/DIV : 1V
TIME/DIV : 2mS

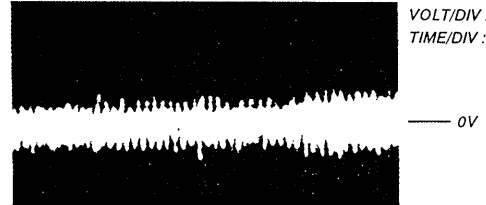

[CD MAIN BOARD]

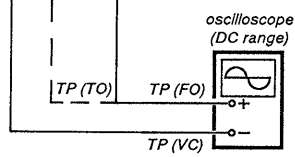
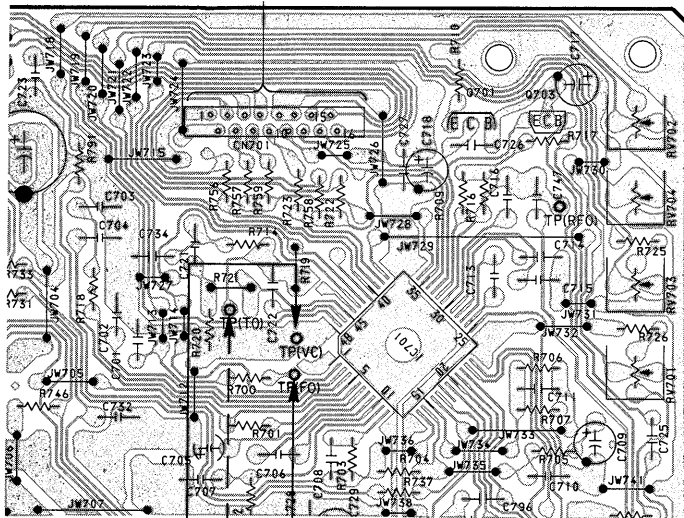

Adjustment Location :

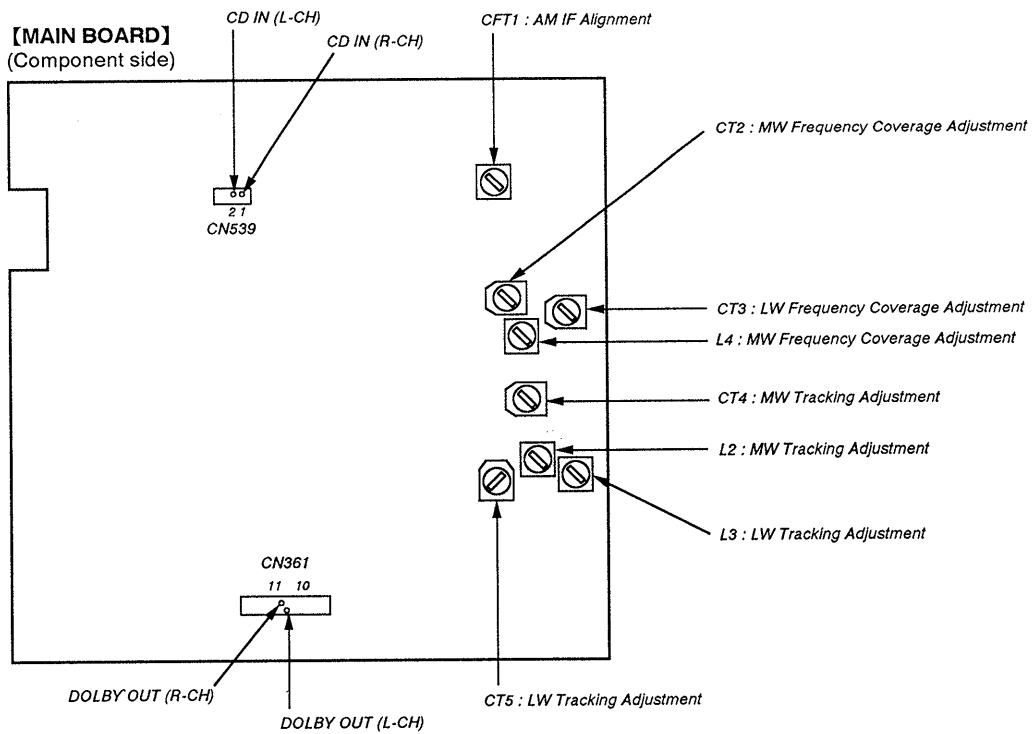
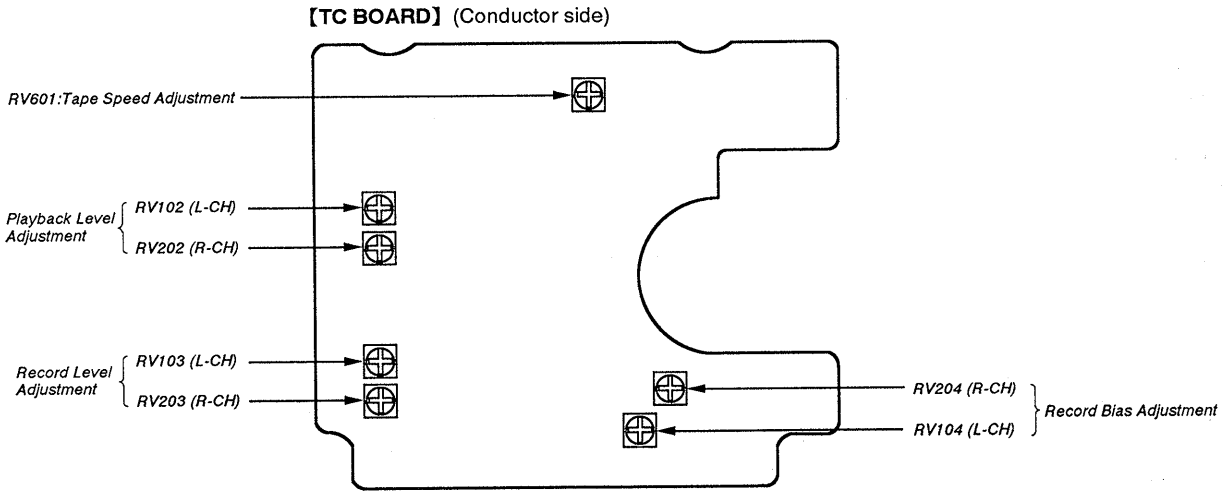

[CD MAIN BOARD] (Conductor side)

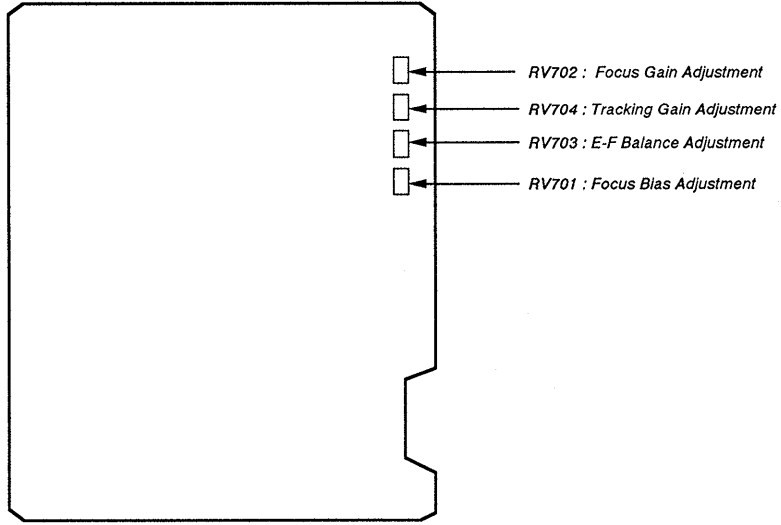

SECTION 6 EXPLANATION OF IC TERMINALS

IC801 CXP83124A-011Q (SYSTEM CONTROL)

Pin No.	Pin name	I/O	Description
1	CASSETTE	I	Cassette tape detect input.
2	SCOR	I	CD SCOR signal input.
3	RMC	I	Remote control signal input.
4	BUZZER	O	Buzzer output.
5	NC	—	Not used (Open).
6	AMS	I	AMS signal input.
7	OP/CL SW	I	CD lid open/close detect input.
8	SQCK	O	Clock output for CD SUB Q.
9	SUBQ	I	CD SUB Q data input.
10	CD MUTE	O	CD mute output.
11	RA CLK	O	Serial clock output for radio.
12	RA COUNT	I	Radio count data input.
13	RA DATA	O	Serial data output for radio.
14	CD CLK	O	Serial clock output for CD DSP (IC702).
15	XLAT	O	Serial clock latch output for CD DSP (IC702).
16	CD DATA	O	Serial data output for CD DSP (IC702).
17	XRST	O	Reset output for CD DSP (IC702), SSP (IC701) and DAC (IC704)
18	SENCE	I	SENCE signal input from CD DSP (IC702).
19	ERASE PROTECT A	I	Erase protect detect input (A side).
20	ERASE PROTECT B	I	Erase protect detect input (B side).
21	B MUTE	O	Radio mute output.
22	RA CE	O	Radio chip enable output.
23	RA ST	I	Radio stereo signal input.
24	MOT-CONT	O	Motor ON/OFF control output.
25	PL-CONT	O	Plunger ON/OFF control output.
26	RADIO	O	Radio function signal output.
27	P-CONT	O	System power ON/OFF control output.
28	B/L-CONT	O	Back light ON/OFF control output.
29	HP-SW	I	Headphones detect input.
30	AC-CHK	I	AC power detect input.
31	KEY 2	I	Key input.
32	KEY 1	I	Key input.
33	KEY 0	I	Key input.
34	D CLASS OFF	I	Power amp mute.
35	NC	—	Not used (Open).
36	J/AE/U	I	Destination select input.
37	SHIFT CLK	O	Shift clock output.
38	RESET	I	Reset input.
39	EXTAL 1	I	Main clock input (4.19MHz).
40	XTAL 1	O	Main clock output (4.19MHz).

Pin No.	Pin name	I/O	Description
41	VSS	–	Connect to ground.
42	XTAL 2	–	Not used (Open).
43	EXTAL 2	–	Not used (Connect to ground).
44	AVREF	–	A/D reference voltage input.
45	AVSS	–	A/D ground terminal.
46	VL	O	LCD drive ON/OFF output.
47 – 49	VLC3 – VLC1	I	LCD drive deviced voltage input.
50 – 53	COM0 – 3	O	LCD common output.
54 – 79	SEG0 – 25	O	LCD segment output.
80	NC	–	Not used.
81	NC	–	Not used.
82	AU CLK	O	Serial clock output for sound processor (IC351).
83	AU DATA	O	Serial data output for sound processor (IC351).
84	AU CE	O	Chip enable output for sound processor (IC351).
85	HP MUTE	O	Headphone mute output.
86	DOLBY	O	DOLBY ON/OFF control output.
87	REC	I	REC detect input.
88	LINE MUTE	O	Line mute output.
89	VDD	–	Power supply (+5V).
90	VDD	–	Power supply (+5V).
91	VSS	–	Connect to ground.
92	TX	I	Sub clock input (32.768kHz).
93	TEX	O	Sub clock output (32.768kHz).
94	REC MUTE	O	REC mute output.
95	BIAS	O	Bias ON/OFF control output.
96	TAPE	O	Tape function select output.
97	CD	O	CD function select output.
98	BEEP/BUZ	O	Beep voltage change signal output.
99	END	I	Tape end detect input.
100	HB-SW	I	Head position detect input.

7-1. BLOCK DIAGRAM (MAIN SECTION)

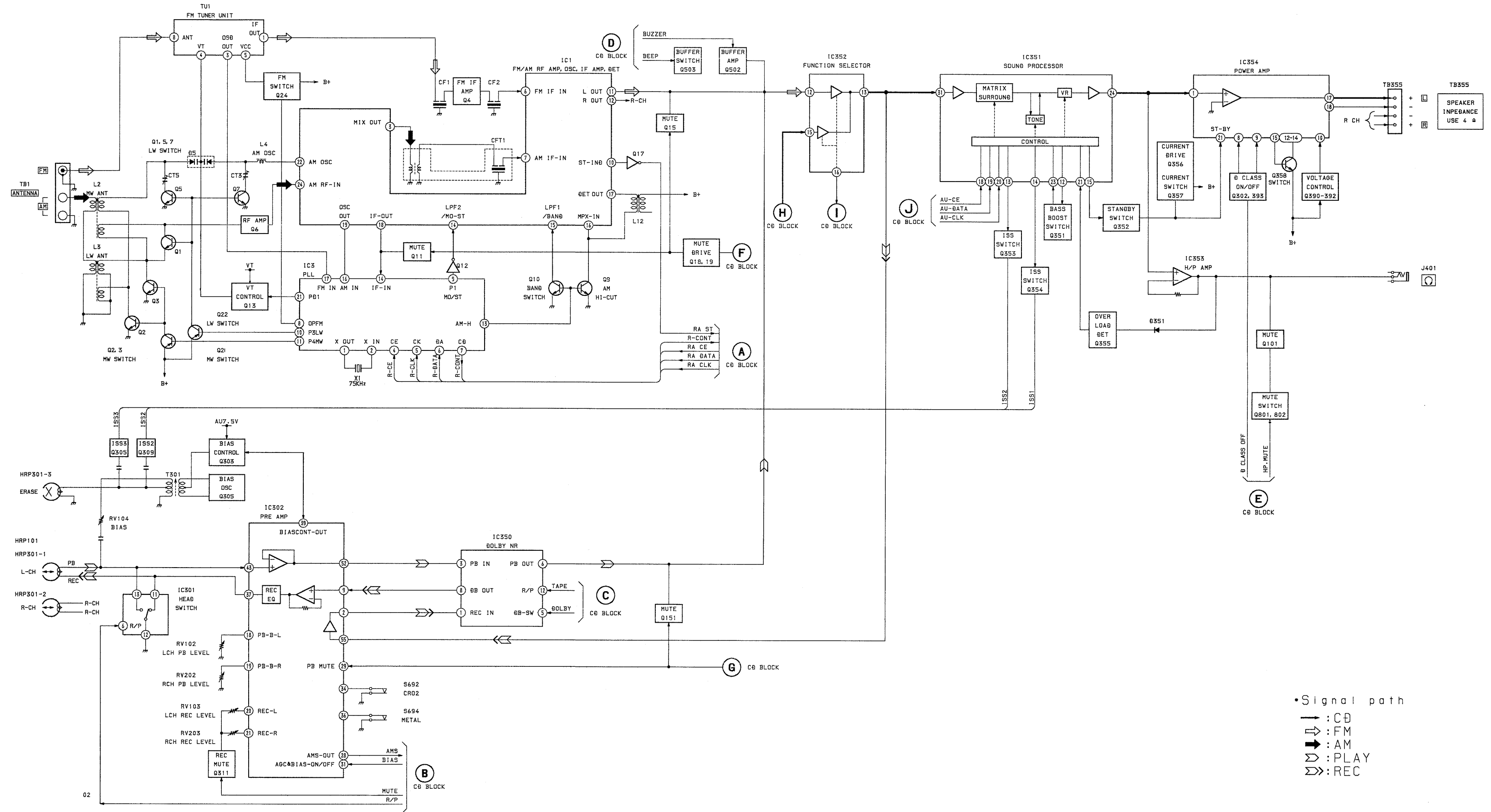

* R-CH is Omitted: See as L-CH

7-2. BLOCK DIAGRAM (CD SECTION)

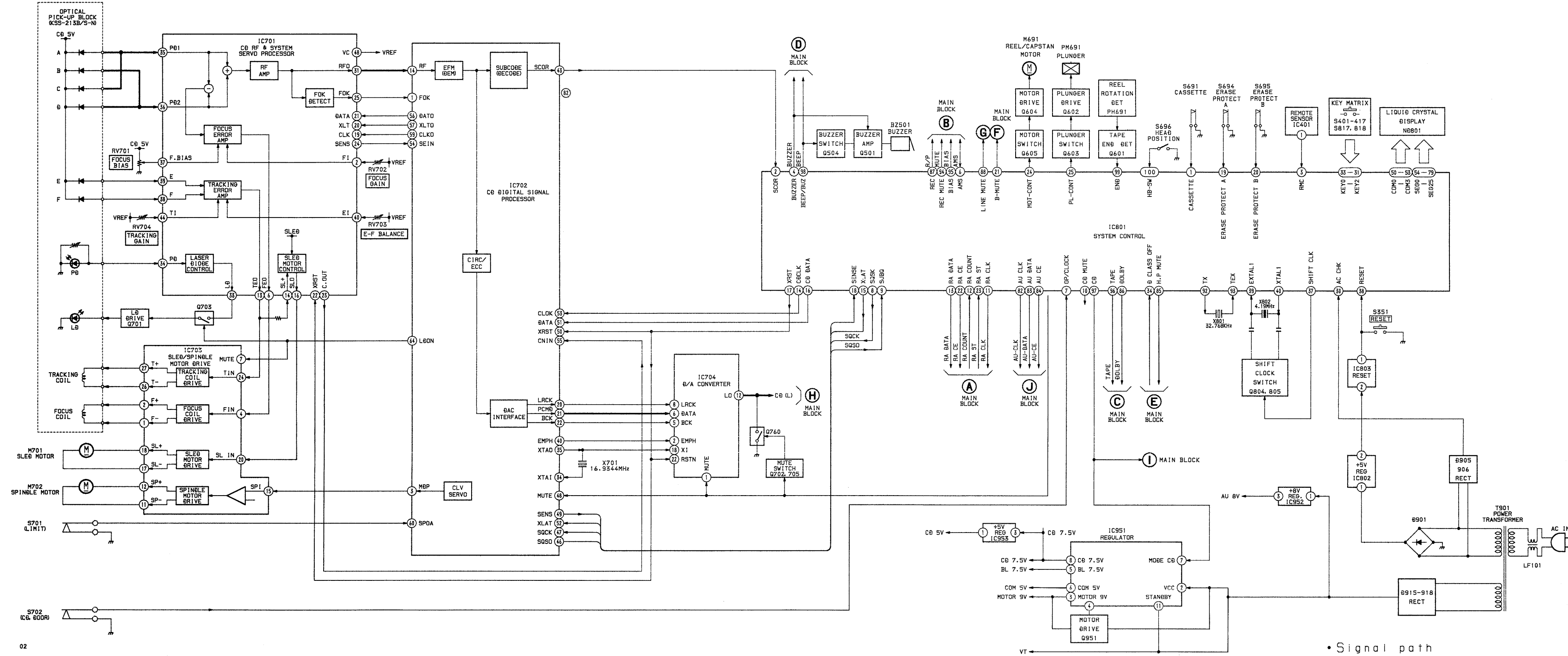

* R-CH is omitted; Same as L-CH

● CIRCUIT BOARDS LOCATION

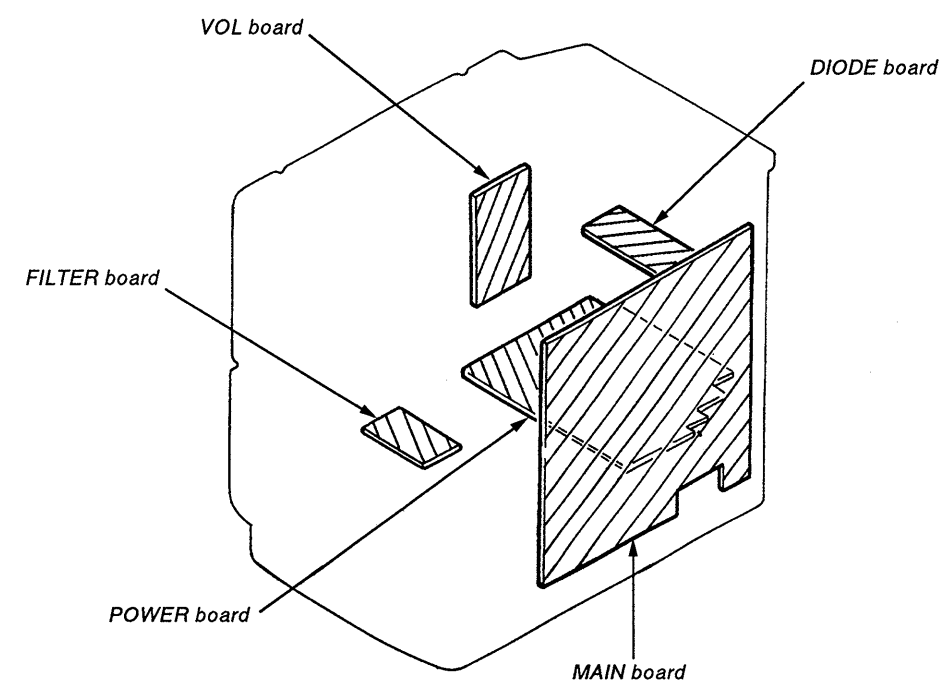
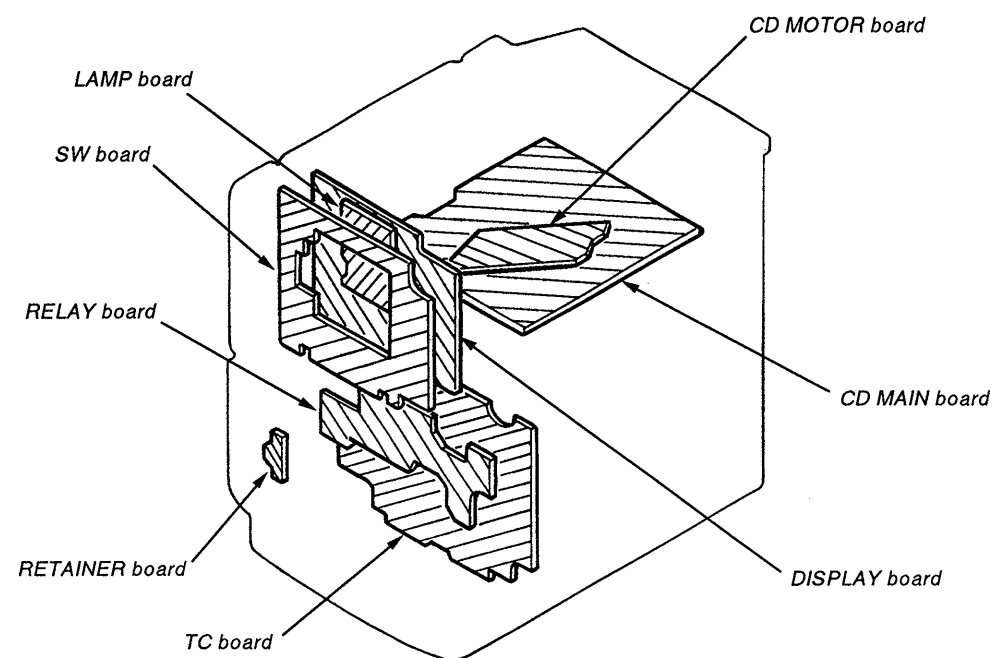

● SEMICONDUCTOR LOCATION

Ref. No.	Location
D1	B-4
D2	B-4
D5	E-5
IC1	D-5
IC2	C-7
IC350	G-9
IC352	F-10
IC355	C-9
Q1	F-5
Q2	F-4
Q3	E-5
Q4	C-4
Q5	F-5
Q6	E-4
Q7	E-4
Q9	E-5
Q10	E-6
Q11	D-6
Q12	D-6
Q13	C-7
Q15	E-6
Q16	E-6
Q17	D-6
Q18	E-7
Q19	F-6
Q21	F-6
Q22	F-6
Q24	E-7
Q151	F-10
Q251	G-10
Q501	H-4
Q502	H-5
Q503	H-5
Q504	H-5
Q957	G-4
Q958	G-4

Note:

- : parts extracted from the component side.
- ▨ : Pattern on the side which is seen.

7-3. PRINTED WIRING BOARDS (MAIN SECTION)

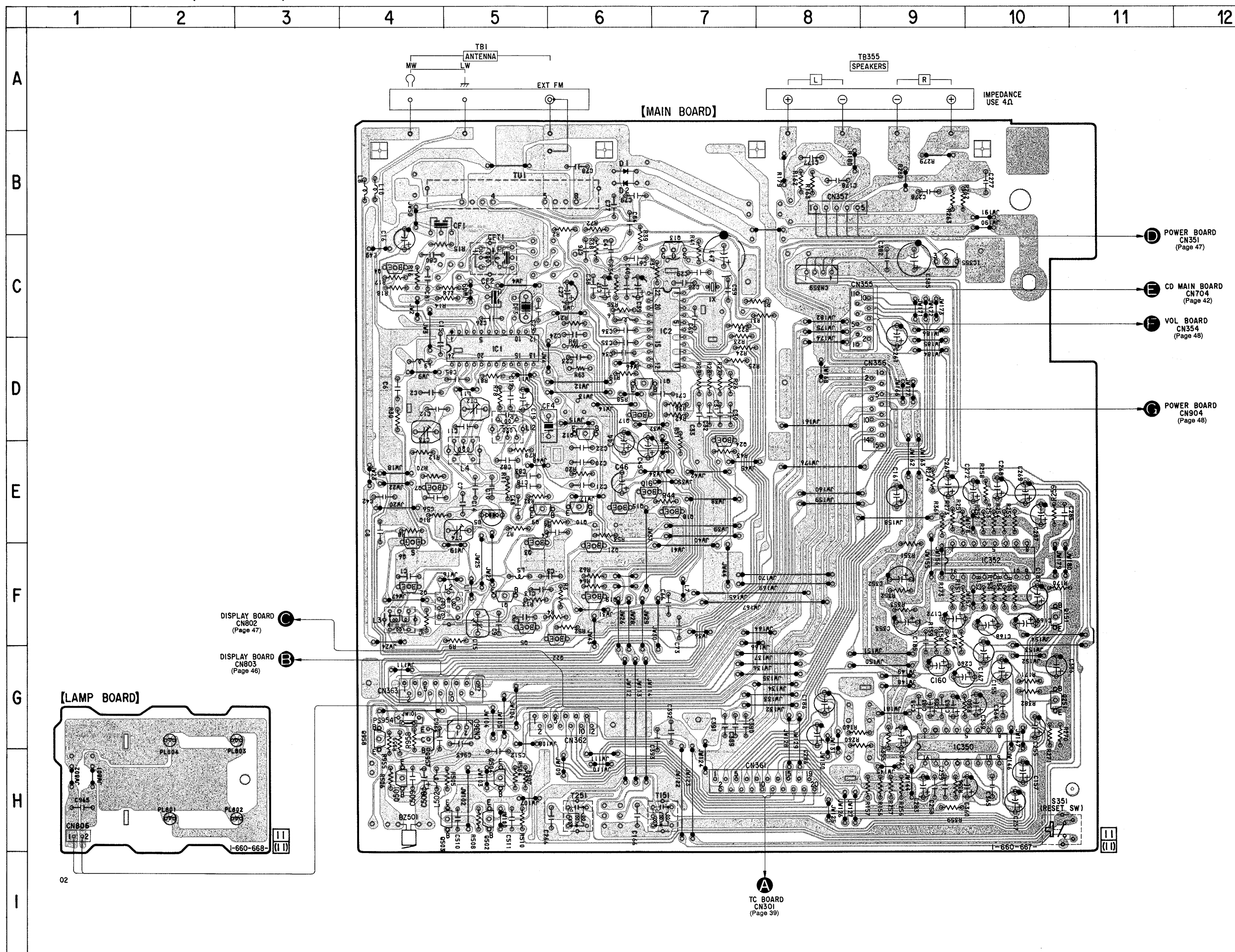

7-4. SCHEMATIC DIAGRAM (MAIN SECTION) Refer to page 54 for IC Block Diagrams.

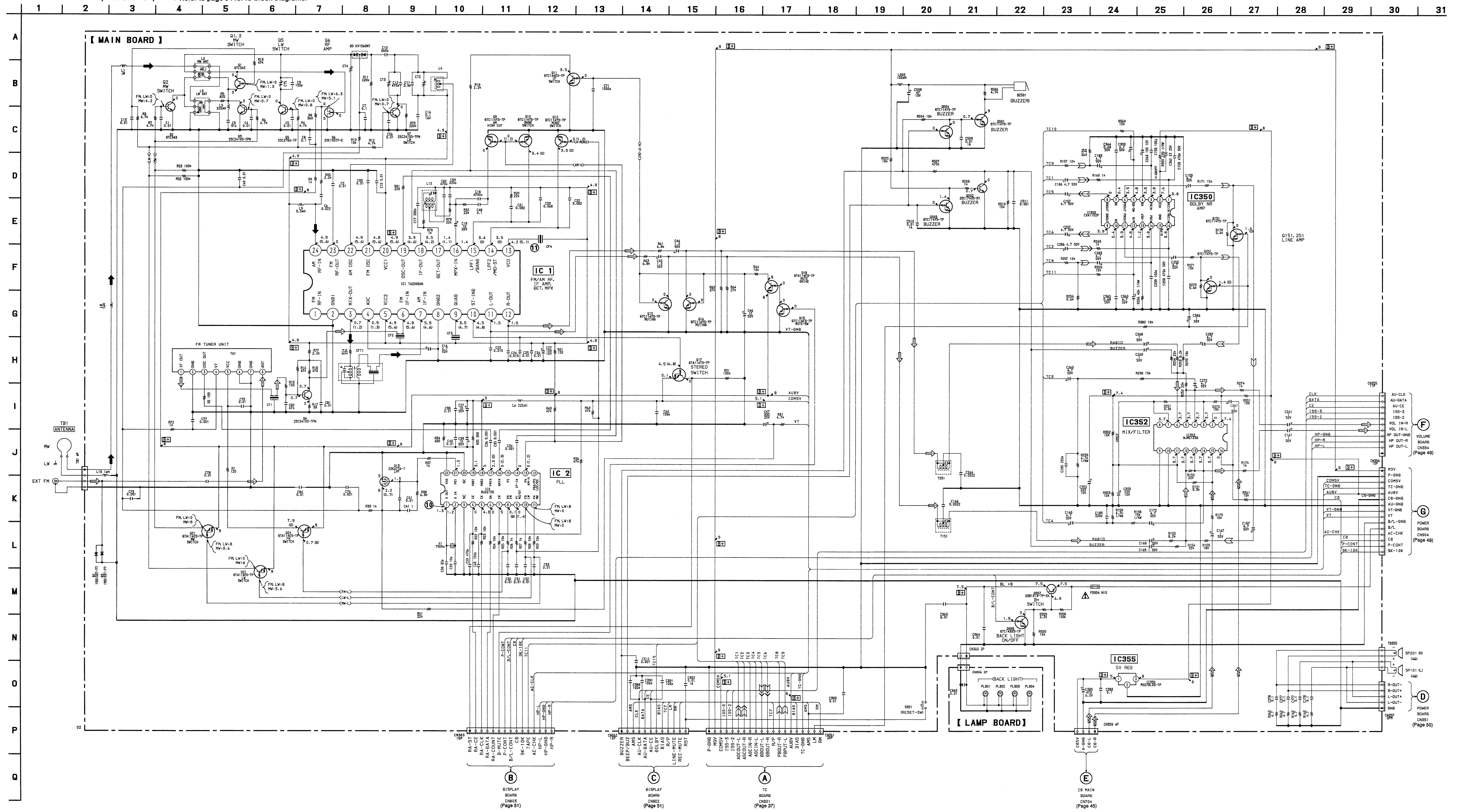

WAVEFORMS (MAIN SECTION)

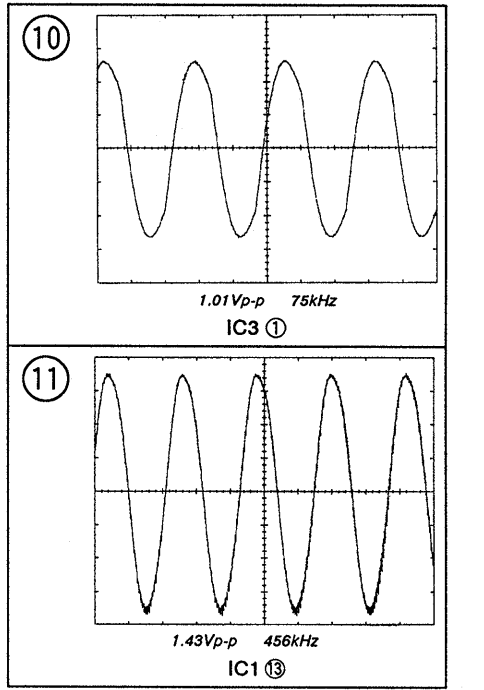

Note :

- All capacitors are in μ F unless otherwise noted. pF: μ μ F 50WV or less are not indicated except for electrolytic and tantalums.
- All resistors are in Ω and $\frac{1}{4}$ W or less unless otherwise specified.
- Δ : internal component.
- \square : nonflammable resistor.
- \square : fusible resistor.

Note : The components identified by mark Δ or dotted line with mark Δ are critical for safety. Replace only with part number specified.

- \square : B+ Line
- Voltage and waveforms are dc with respect to ground under no-signal (detuned) conditions.
- no mark : FM
- () : MW
- () : LW

• Voltages are taken with a VOM (Input impedance 10M Ω). Voltage variations may be noted due to normal production tolerances.

• Waveforms are taken with an oscilloscope. Voltage variations may be noted due to normal production tolerances.

• Circled numbers refer to waveforms.

• Signal path.

- \rightarrow : FM
- \rightarrow : AM

• WAVEFORM (TC SECTION)

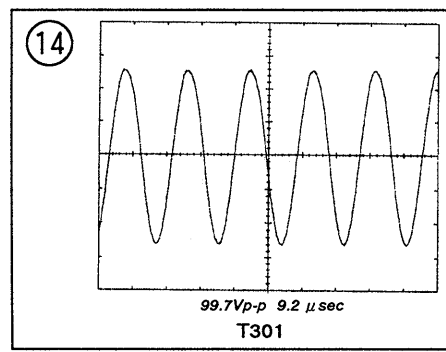

• IC BLOCK DIAGRAM (TC SECTION)

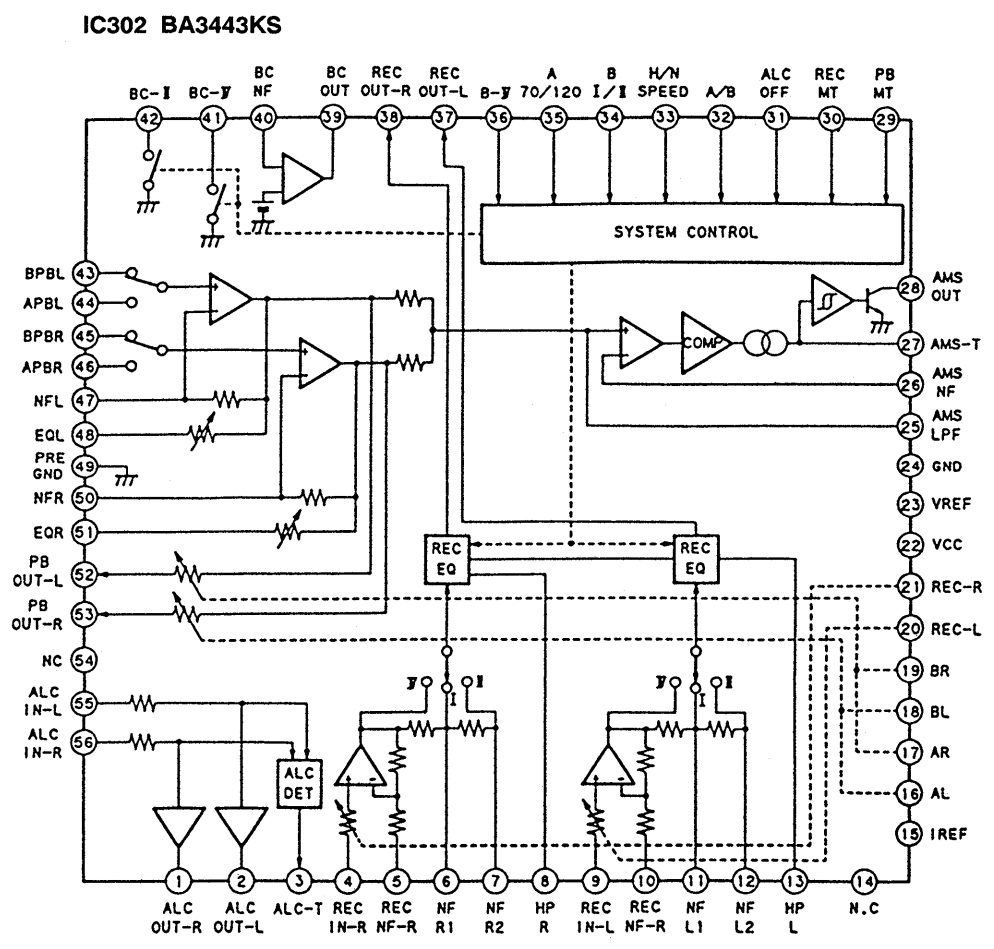

Note :

- All capacitors are in μ F unless otherwise noted. pF, μ F, μ F 50WV or less are not indicated except for electrolytics and tantalums.
- All resistors are in Ω and $\frac{1}{4}$ W or less unless otherwise specified.

Note : The components identified by mark Δ or dotted line with mark Δ are critical for safety. Replace only with part number specified.

- B+ : B+ Line
- \square : adjustment for repair.
- Voltage and waveforms are dc with respect to ground under no-signal conditions.
- no mark : PLAY
- () : REC
- Voltages are taken with a VOM (Input impedance 10M Ω). Voltage variations may be noted due to normal production tolerances.
- Waveforms are taken with an oscilloscope. Voltage variations may be noted due to normal production tolerances.
- Circled numbers refer to waveforms.
- Signal path.
- \rightarrow : PB
- \rightarrow : REC

7-5. SCHEMATIC DIAGRAM (TC SECTION)

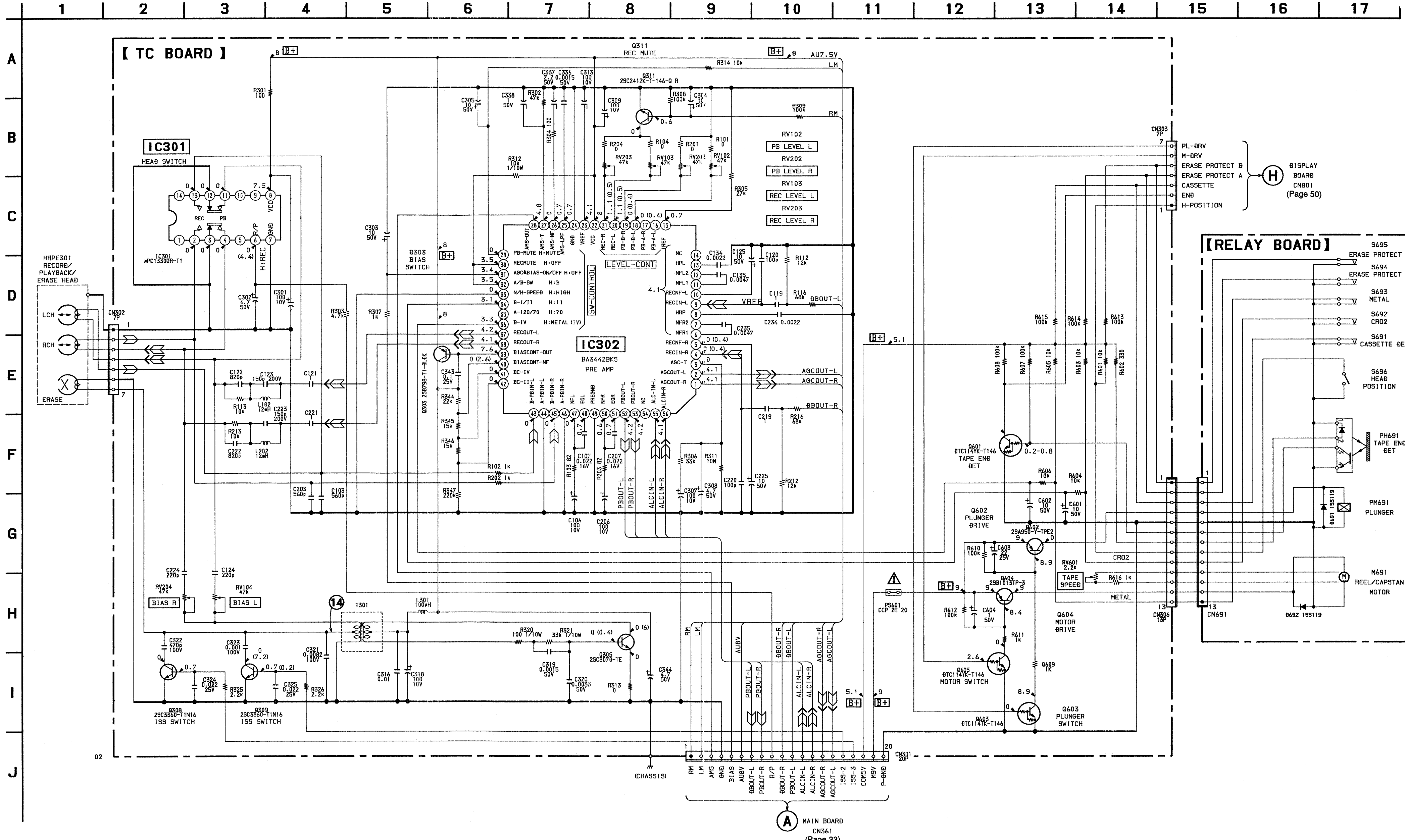

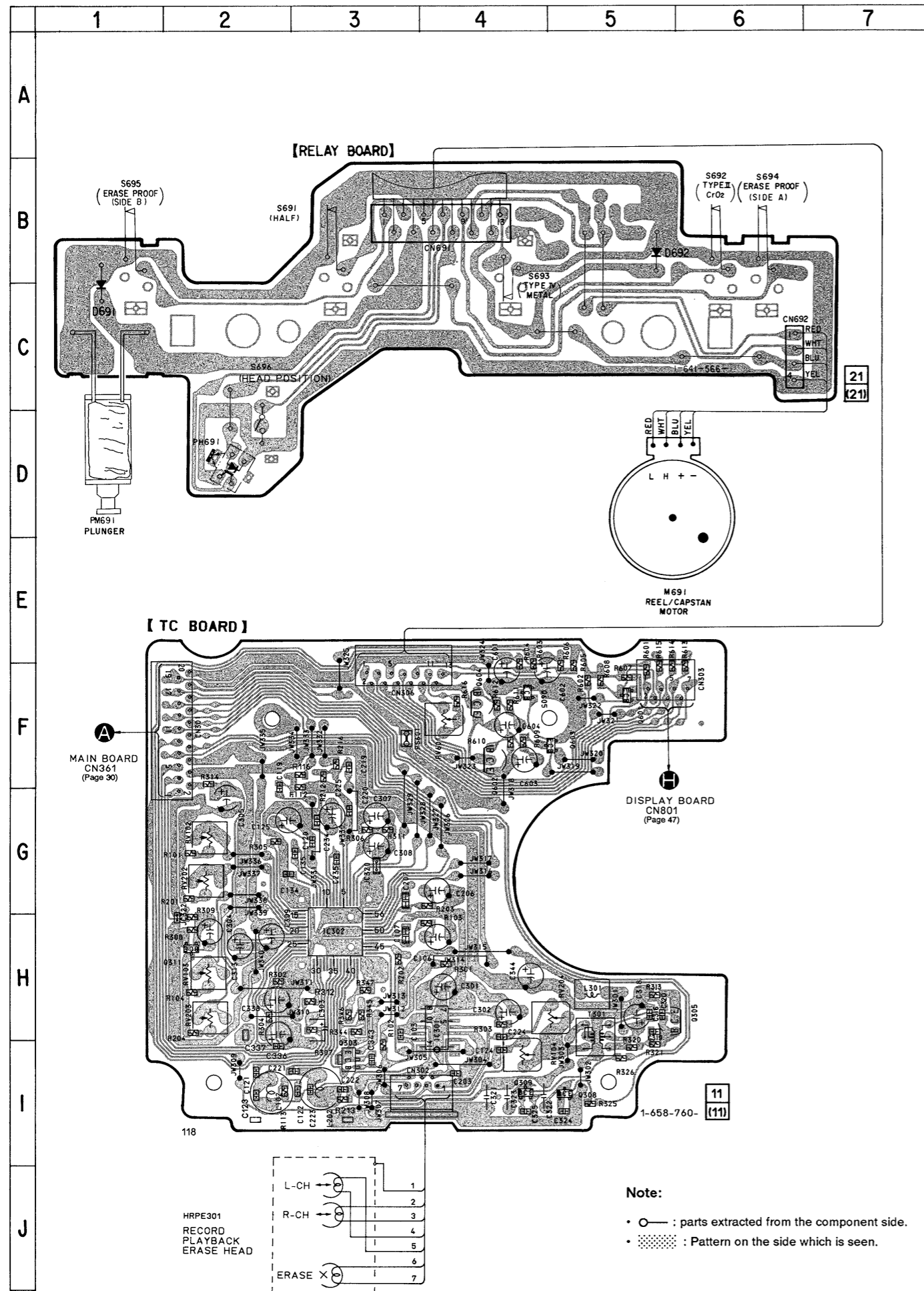

● SEMICONDUCTOR LOCATION

Ref. No.	Location
D691	C - 1
D692	B - 5
IC301	H - 4
IC302	H - 3
PH691	D - 2
Q303	I - 3
Q305	H - 5
Q308	I - 5
Q309	I - 4
Q311	H - 2
Q601	F - 5
Q602	F - 4
Q603	F - 5
Q604	F - 4
Q605	F - 4

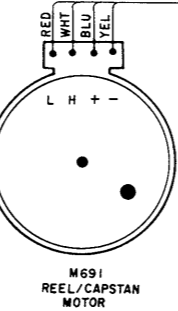

M691 REEL/CAPSTAN MOTOR

1-658-760- (11)

118

HRPE301
RECORD
PLAYBACK
ERASE HEAD

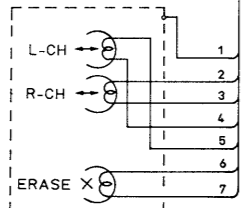

Note:

- — : parts extracted from the component side.
- : Pattern on the side which is seen.

7-7. PRINTED WIRING BOARDS (CD SECTION)

● SEMICONDUCTOR LOCATION

Ref. No.	Location
D702	I-3
D703	I-3
IC701	F-6
IC702	H-6
IC703	E-4
IC704	H-4
Q701	E-6
Q702	H-3
Q703	E-7
Q705	H-3
Q760	G-4
Q770	G-4

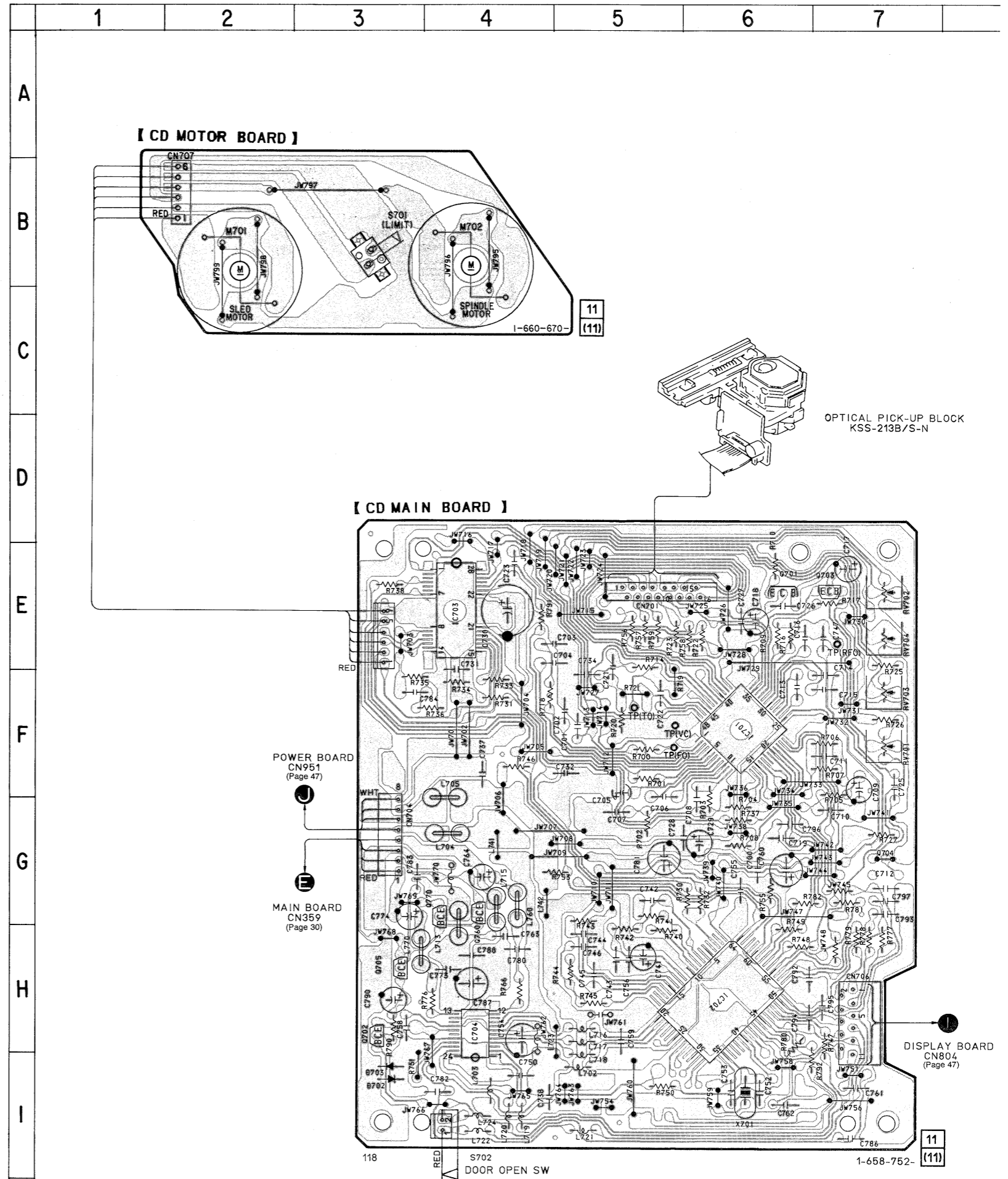

Note:

- — : parts extracted from the component side.
- ⊙ : Pattern on the side which is seen.

Note :

- All capacitors are in μF unless otherwise noted. pF: μF 50WV or less are not indicated except for electrolytics and tantalums.
- All resistors are in Ω and $\frac{1}{4}W$ or less unless otherwise specified.
- Note : The components identified by mark Δ or dotted line with mark Δ are critical for safety. Replace only with part number specified.
- \square : B+ Line
- \square : adjustment for repair.
- Voltage and waveforms are dc with respect to ground under no-signal conditions.
- no mark : CD

- Voltages are taken with a VOM (Input impedance $10M \Omega$). Voltage variations may be noted due to normal production tolerances.
- Waveforms are taken with an oscilloscope. Voltage variations may be noted due to normal production tolerances.
- Circled numbers refer to waveforms.
- Signal path.

7-8. SCHEMATIC DIAGRAM (CD SECTION) • Refer to page 53 for Waveforms. • Refer to page 55 for IC Block Diagrams.

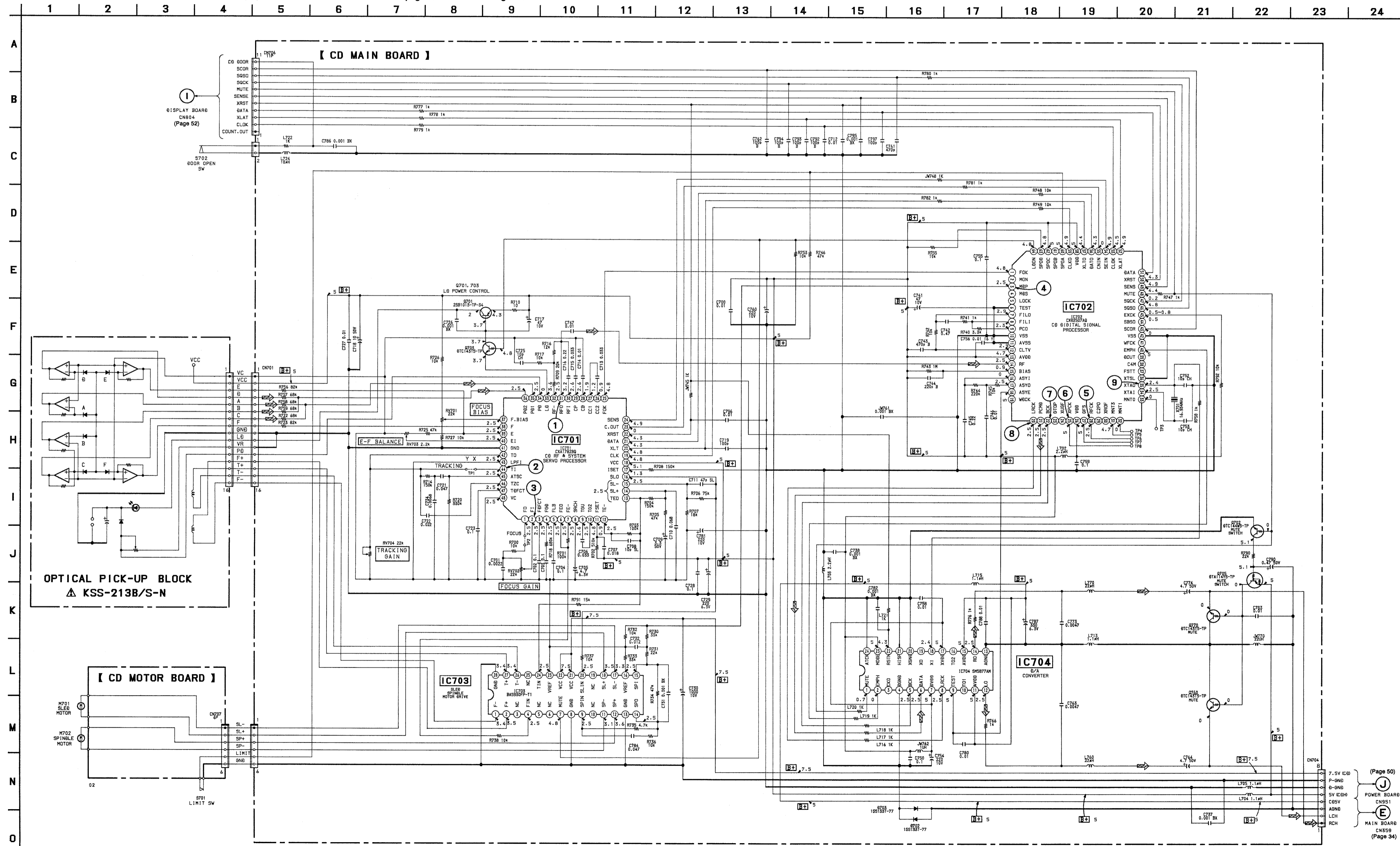

(Page 50)
POWER BOARD
CN951
(E)
MAIN BOARD
CN559
(Page 34)

7-9. PRINTED WIRING BOARDS (DISPLAY SECTION)

● SEMICONDUCTOR LOCATION

Ref. No.	Location
D351	A - 14
D352	A - 10
D390	C - 10
D402	D - 6
D403	D - 6
D801	H - 5
D802	G - 2
D901	G - 10
D905	G - 10
D906	G - 10
D915	D - 10
D916	D - 11
D917	D - 10
D918	D - 11
IC351	B - 15
IC353	C - 17
IC354	B - 10
IC401	C - 6
IC501	I - 3
IC801	G - 4
IC802	H - 6
IC803	G - 5
IC951	B - 11
IC952	C - 11
IC953	C - 10
Q101	H - 2
Q201	H - 2
Q302	C - 10
Q351	B - 16
Q352	B - 14
Q353	B - 14
Q354	B - 14
Q355	A - 15
Q356	D - 9
Q357	D - 8
Q358	B - 10
Q390	B - 10
Q391	C - 10
Q392	B - 10
Q393	C - 10
Q801	H - 2
Q802	H - 2
Q804	G - 3
Q805	G - 3
Q951	B - 12

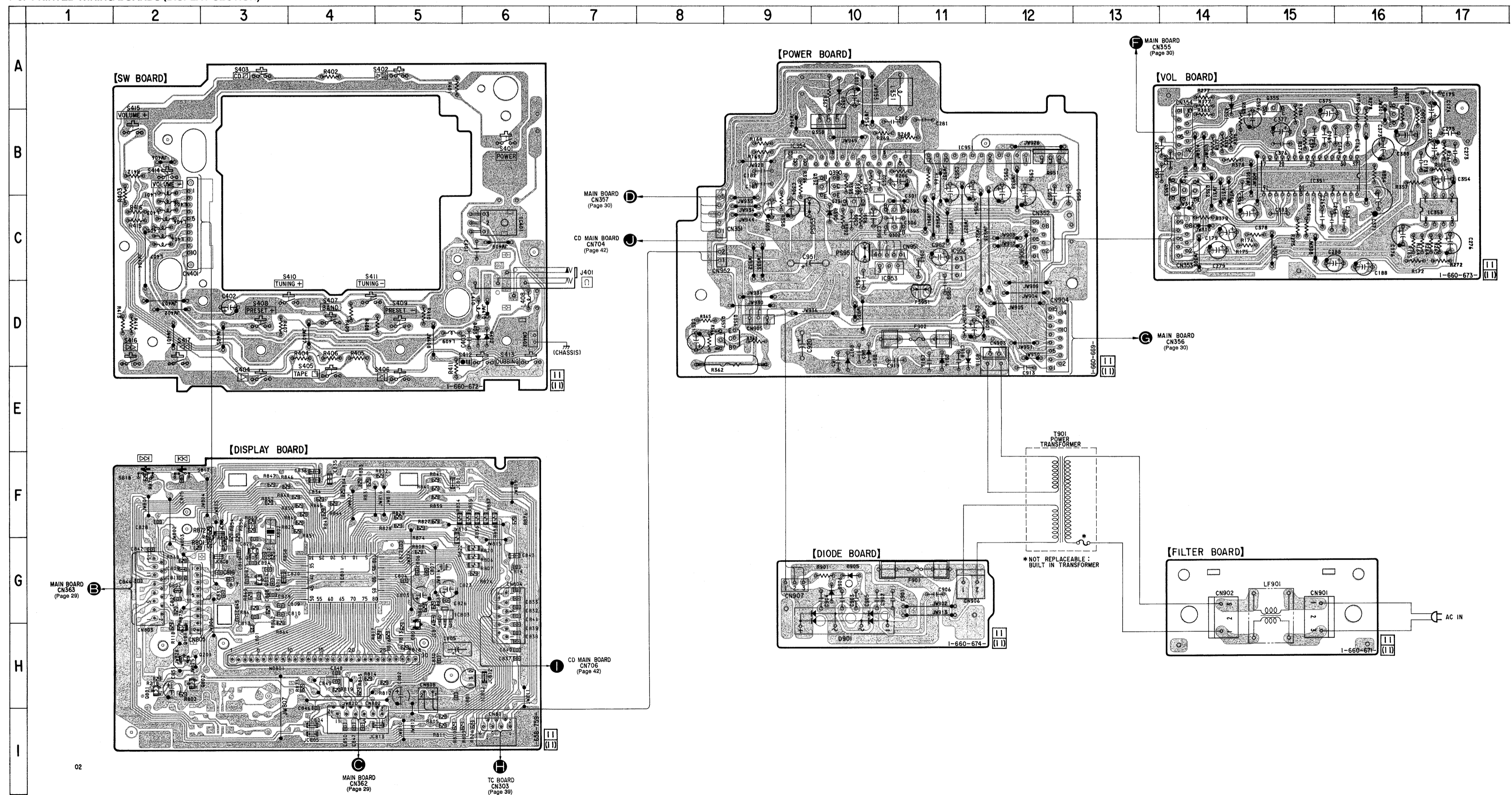

Note:
 ○ : parts extracted from the component side.
 ◐ : Pattern on the side which is seen.

Note :

- All capacitors are in μ F unless otherwise noted. pF: μ F
- 50WV or less are not indicated except for electrolytics and tantalums.
- All resistors are in Ω and $\frac{1}{4}$ W or less unless otherwise specified.

Note : The components identified by mark Δ or dotted line with mark Δ are critical for safety. Replace only with part number specified.

- [B+]** : B+ Line
- Waveform and waveforms are dc with respect to ground under no-signal conditions.
- no mark : FM
- Voltagess are taken with a VOM (Input impedance 10M Ω). Voltage variations may be noted due to normal production tolerances.
- Waveforms are taken with an oscilloscope. Voltage variations may be noted due to normal production tolerances.
- Circled numbers refer to waveforms.
- Signal path
- \Rightarrow : FM

7-10. SCHEMATIC DIAGRAM (DISPLAY SECTION)

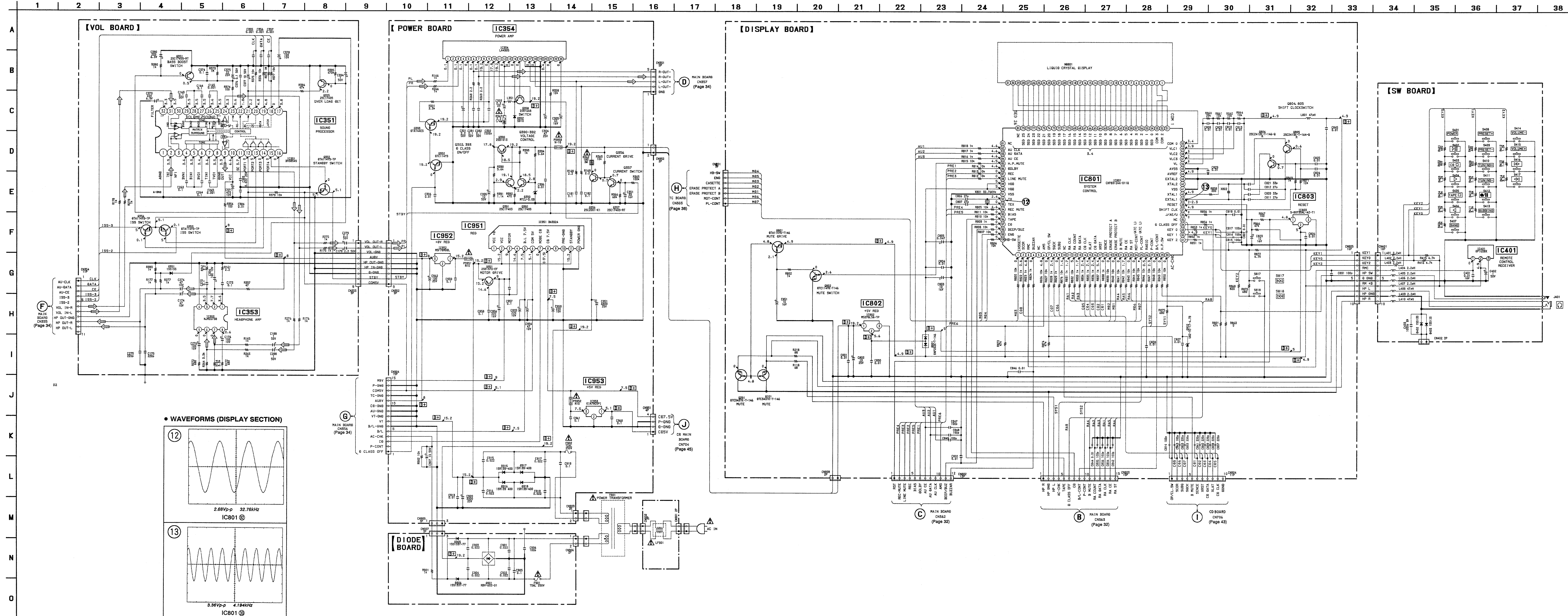

• WAVEFORMS (DISPLAY SECTION)

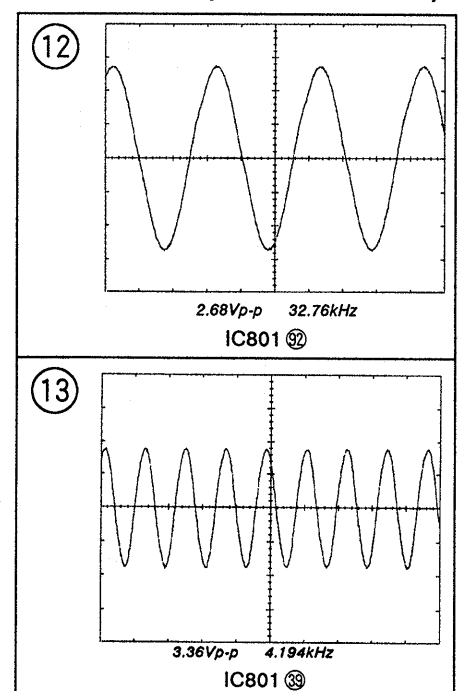

• WAVEFORMS (CD SECTION)

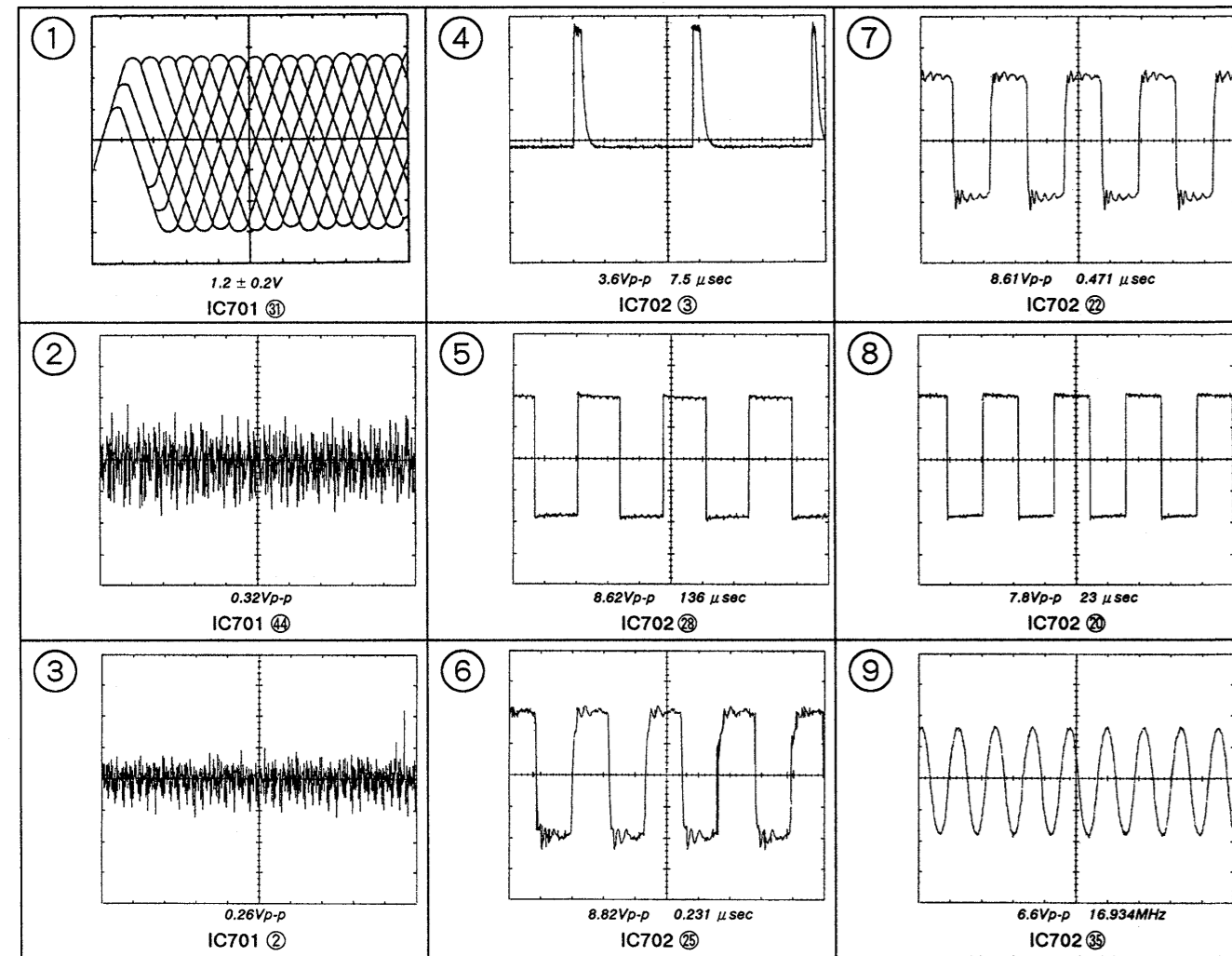

• IC BLOCK DIAGRAMS (MAIN SECTION)

IC1 TA2008AN

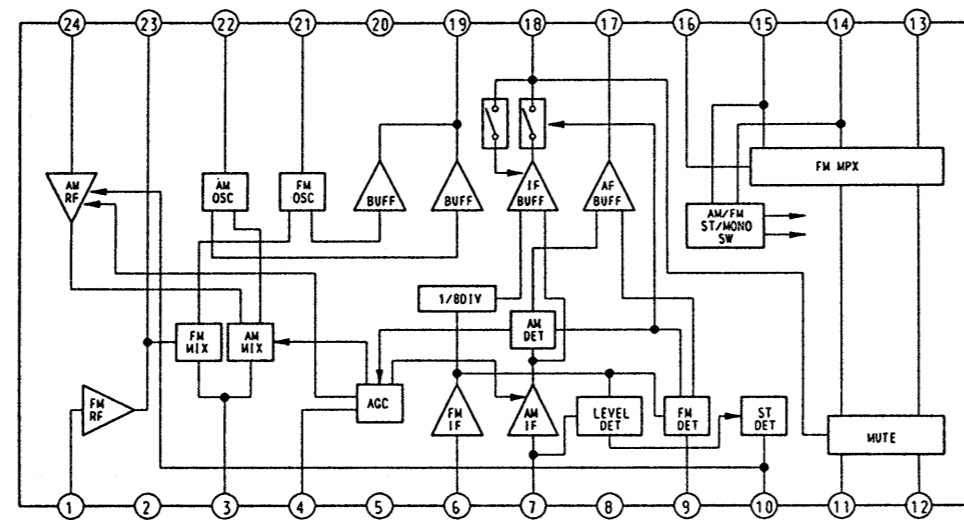

IC350 CXA1102P

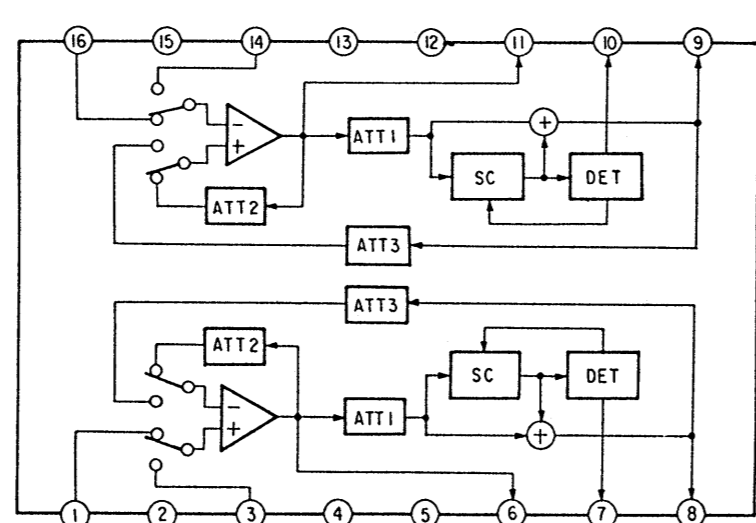

IC354 LA4905

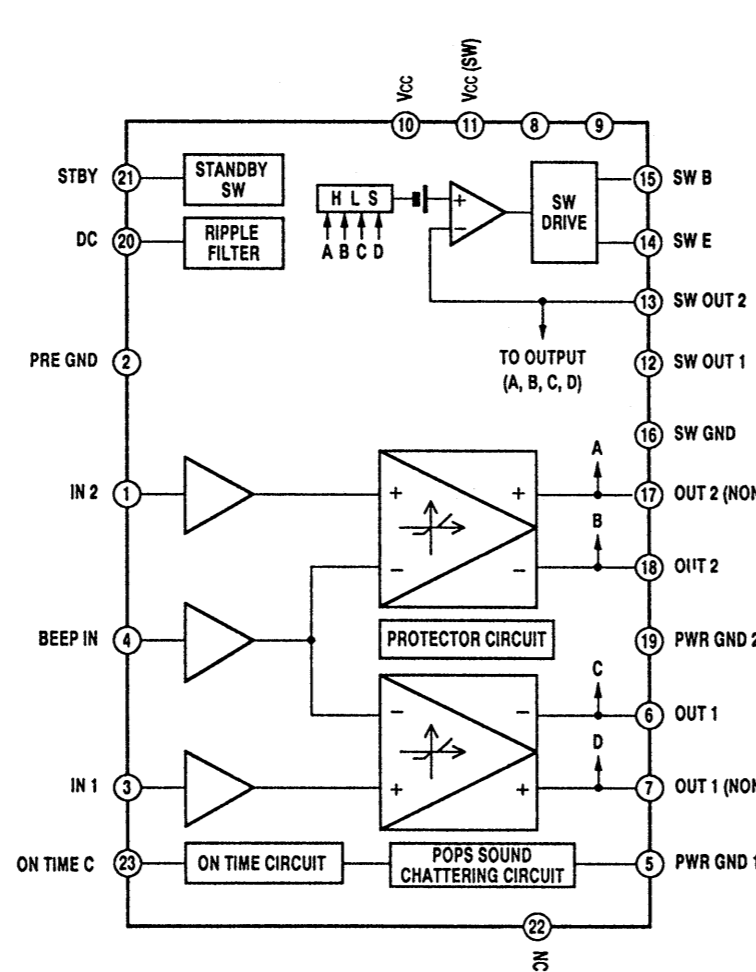

IC951 BA3924

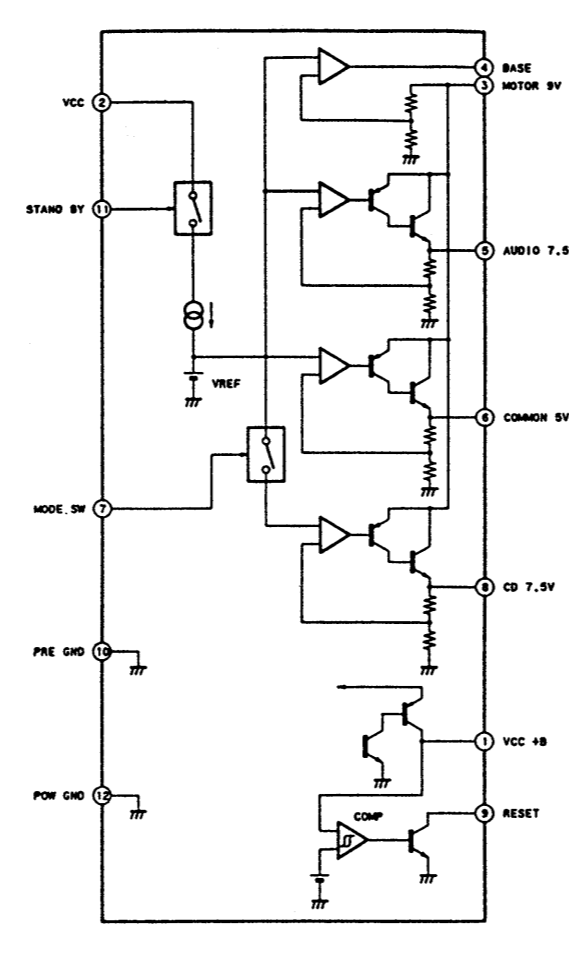

• IC BLOCK DIAGRAMS (CD SECTION)

IC701 CXA1782BQ

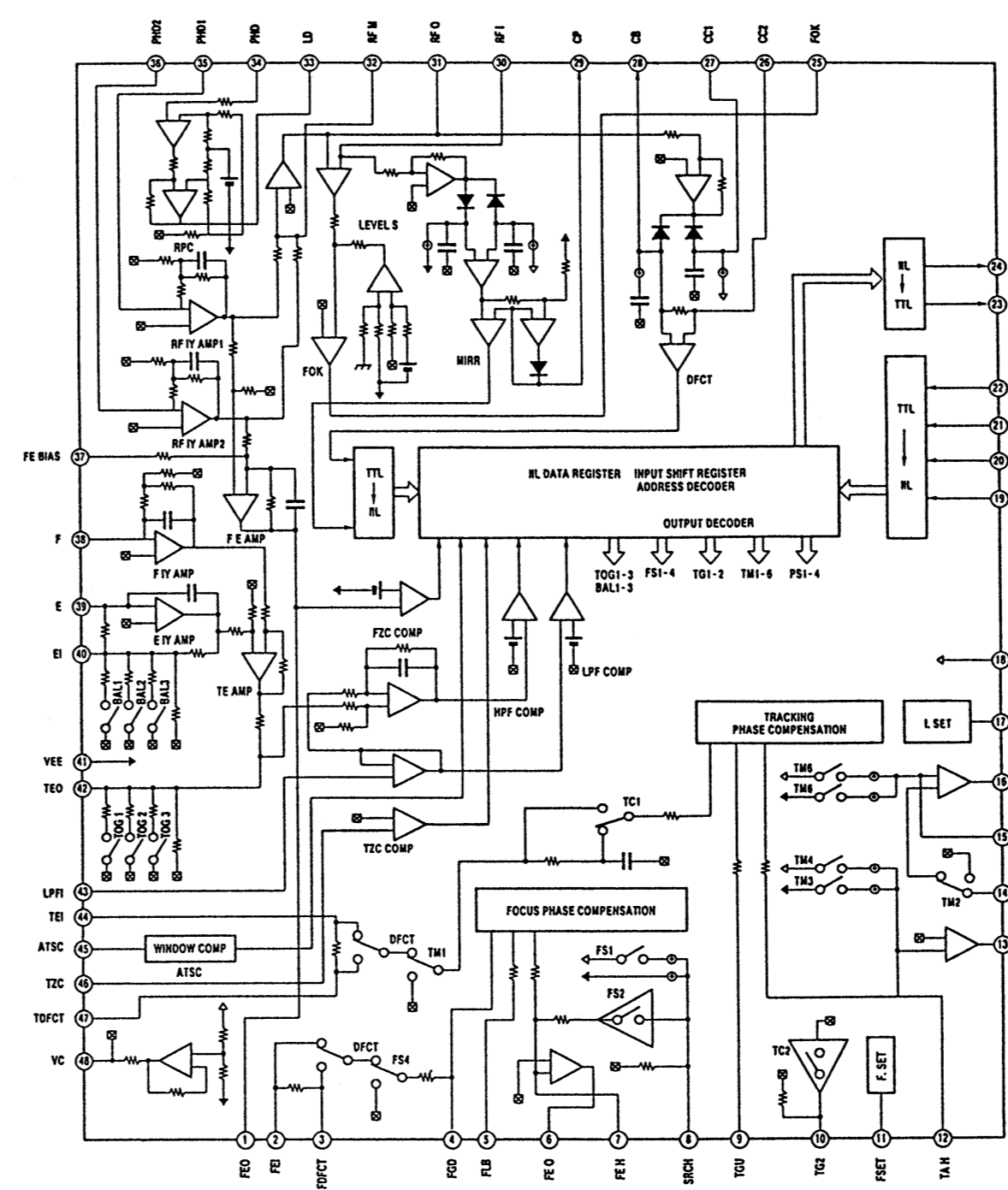

IC702 CXD2507AQ

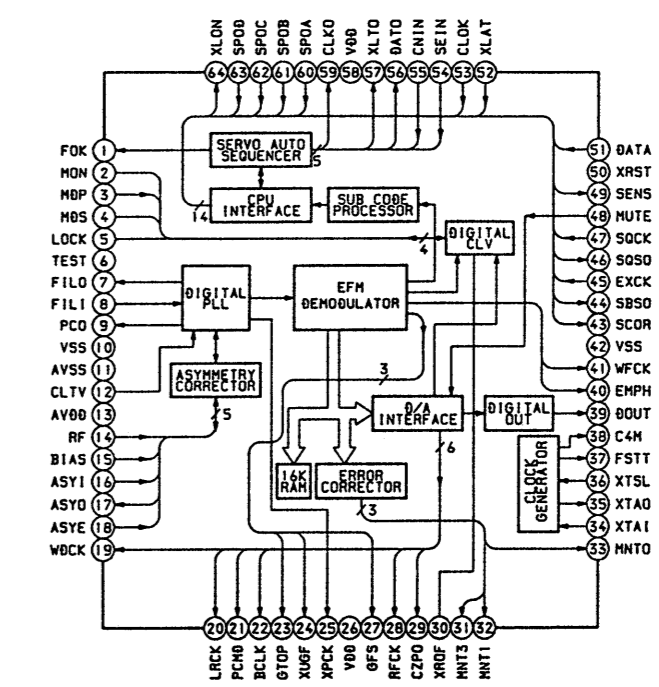

IC703 BA5930FP

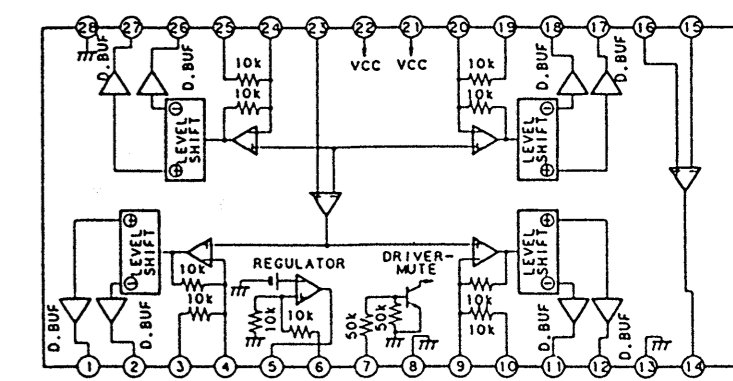

IC704 SM5877AM-E2

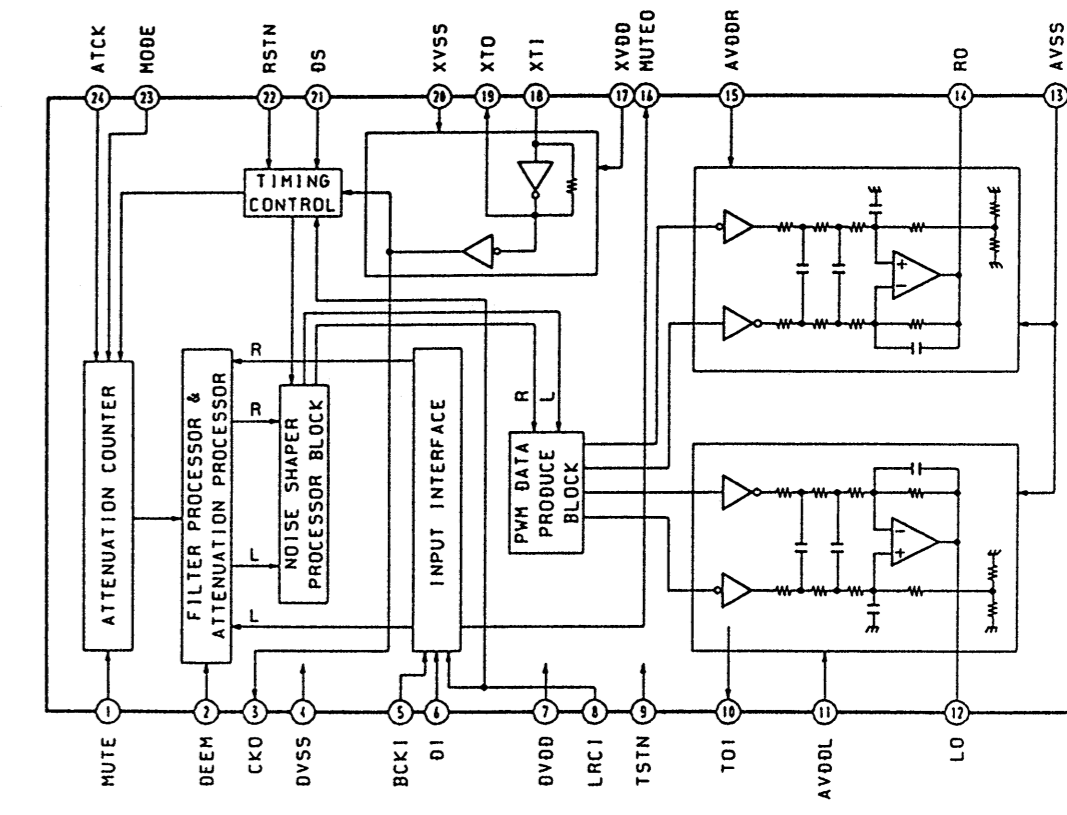

SECTION 8 EXPLODED VIEWS

NOTE :

- -XX, -X mean standardized parts, so they may have some difference from the original one.
- Items marked “ * ” are not stocked since they are seldom required for routine service. Some delay should be anticipated when ordering these items.

- The mechanical parts with no reference number in the exploded views are not supplied.
- Hardware (# mark) list and accessories and packing materials are given in the last of this parts list.

The components identified by mark Δ or dotted line with mark Δ are critical for safety.
Replace only with part number specified.

8-1. CHASSIS SECTION

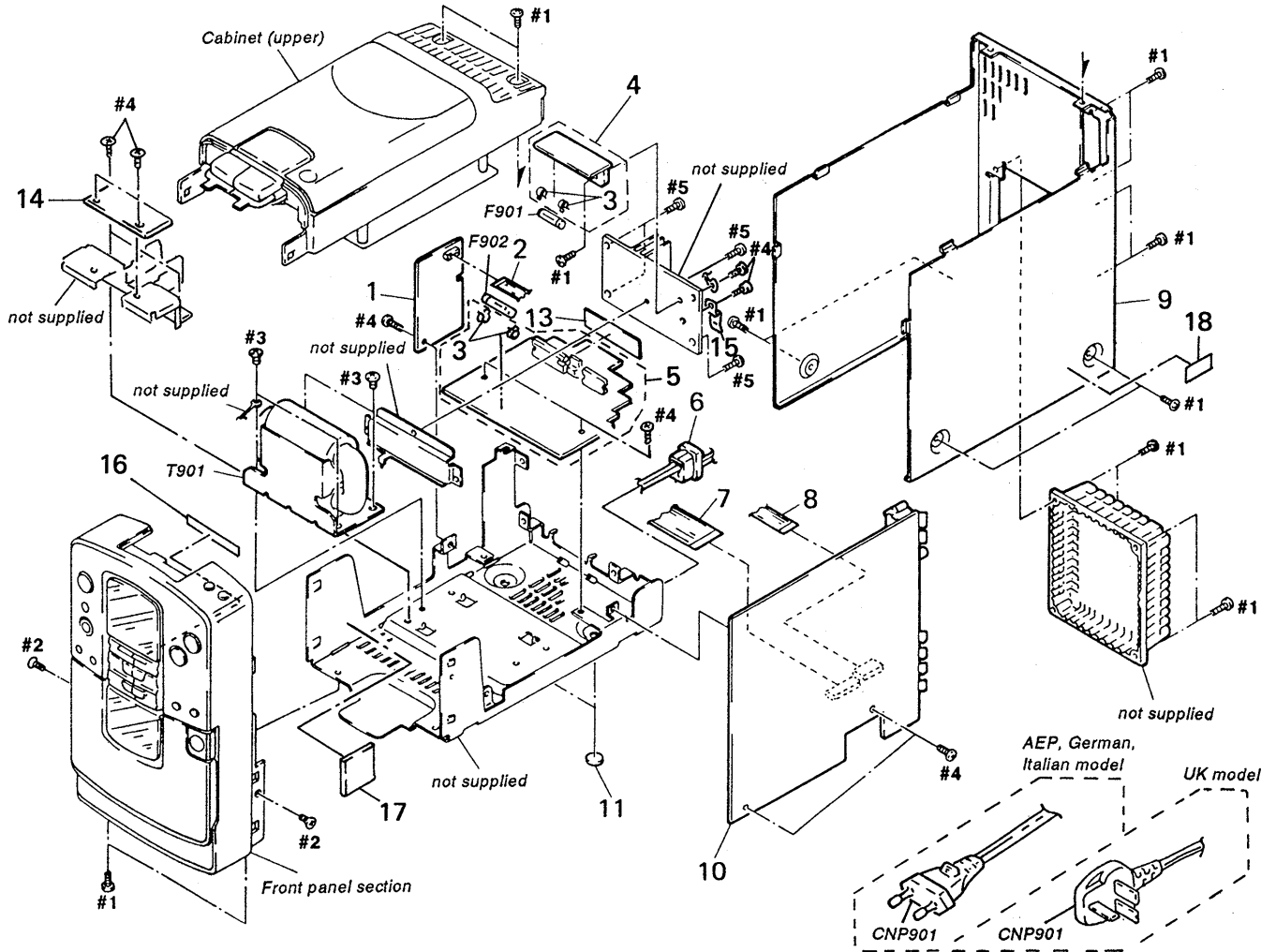

Ref. No.	Part No.	Description	Remark	Ref. No.	Part No.	Description	Remark
* 1	A-3305-718-A	VOL BOARD, COMPLETE		* 13	3-932-095-01	SHEET, INSULATING	
2	1-776-441-11	WIRE, PARALLEL (FFC) (9 CORE)		* 14	1-660-671-11	FILTER BOARD	
3	1-533-313-11	HOLDER, FUSE		15	3-938-779-01	SPRING (IC)	
* 4	A-3305-719-A	DIODE BOARD, COMPLETE		16	3-939-803-01	PAPER (FRONT), SHIELD	
* 5	A-3305-717-A	POWER BOARD, COMPLETE		* 17	4-928-456-01	CUSHION	
6	3-703-244-11	BUSHING (2104), CORD		* 18	4-941-548-01	LABEL, CLASS (1)	
7	1-776-439-11	WIRE, PARALLEL (FFC) (15 CORE)		Δ CNP901	1-575-651-11	CORD, POWER (AEP, German, Italian)	
8	1-776-440-11	WIRE, PARALLEL (FFC) (11 CORE)		Δ CNP901	1-696-570-21	CORD, POWER (UK)	
* 9	3-929-616-11	PLATE, REAR		Δ F901	1-533-472-11	FUSE, GLASS TUBE (DIA. 5) (5A/250V)	
* 10	A-3305-716-A	MAIN BOARD, COMPLETE		Δ F902	1-533-468-11	FUSE, GLASS TUBE (DIA. 5) (2A/250V)	
* 11	3-940-657-21	FOOT (FELT)		Δ T901	1-429-573-11	TRANSFORMER, POWER	

8-2. FRONT PANEL SECTION

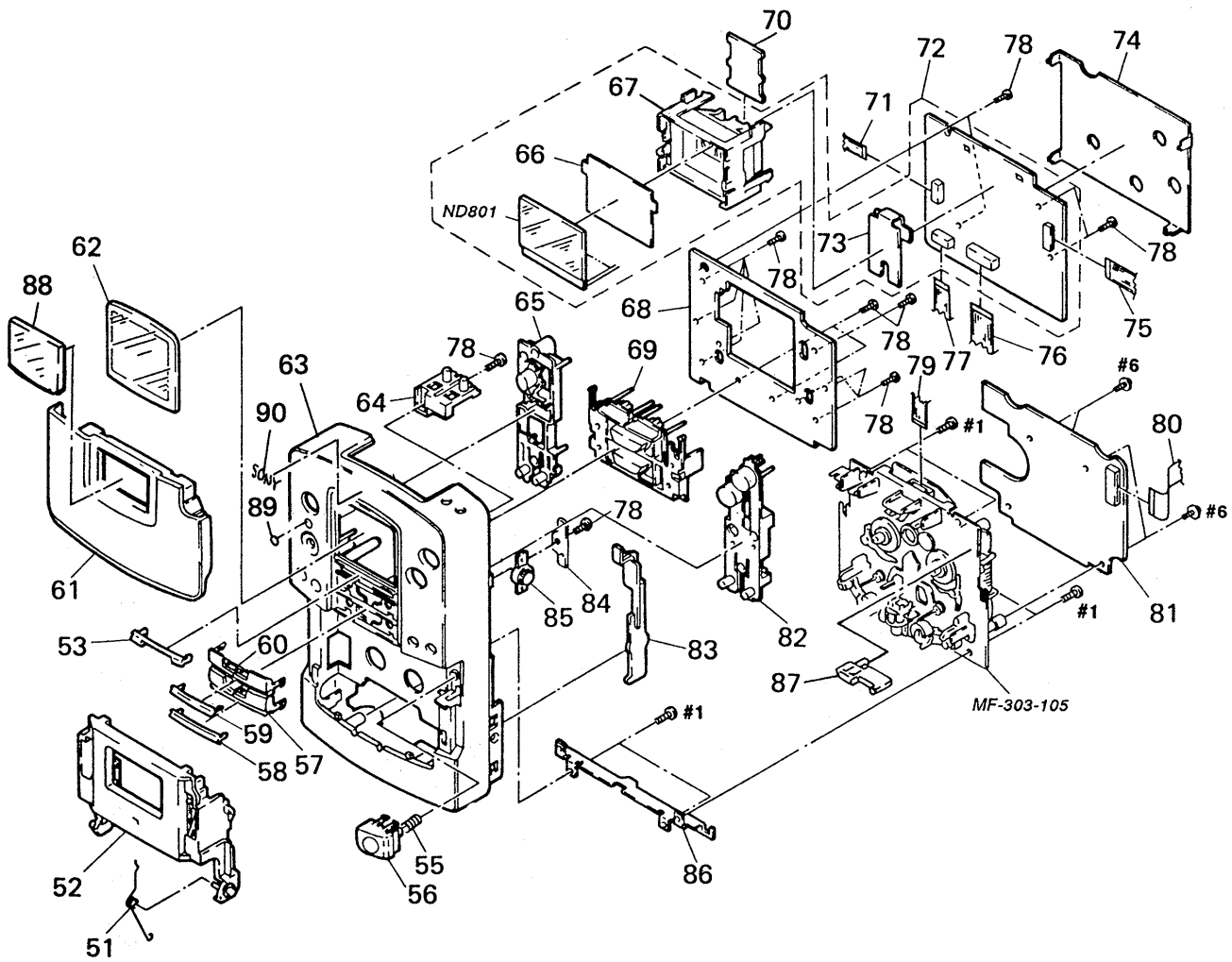

Ref. No.	Part No.	Description	Remark	Ref. No.	Part No.	Description	Remark
51	3-929-635-01	SPRING (CASSETTE)		* 72	A-3305-714-A	DISPLAY BOARD, COMPLETE	
52	3-929-634-01	HOLDER, CASSETTE		* 73	3-932-100-01	PLATE (DISPLAY) (A), SHIELD	
53	3-929-625-01	ESCUTCHEON		* 74	3-932-099-01	SHIELD (DISPLAY) (B)	
55	3-929-630-01	SPRING (EJECT)		75	1-776-039-11	WIRE, PARALLEL (FFC) (15 CORE)	
56	3-929-629-01	BUTTON (EJECT)		76	1-776-040-11	WIRE, PARALLEL (FFC) (12 CORE)	
57	3-929-626-11	BUTTON (PRESET)		77	1-776-036-11	WIRE, PARALLEL (FFC) (7 CORE)	
58	3-929-627-11	ESCUTCHEON (PERSET)		78	4-931-757-41	SCREW (DIA.2.6X10) (IT3B)	
59	3-929-627-01	ESCUTCHEON (PERSET)		79	1-765-435-11	WIRE, PARALLEL (FFC) (13 CORE)	
60	3-929-626-01	BUTTON (PRESET)		80	1-776-038-11	WIRE, PARALLEL (FFC) (20 CORE)	
61	3-929-732-01	LID, CASSETTE		* 81	A-3305-436-A	TC BOARD, COMPLETE	
62	3-929-623-01	WINDOW (LCD)		82	3-929-619-01	BUTTON (VOLUME/T)	
63	3-929-621-01	CABINET (FRONT)		* 83	3-929-620-01	LEVER (EJECT)	
64	3-929-622-01	BUTTON (CD-SEARCH)		* 84	1-661-719-11	PC BOARD, RETAINER	
65	3-929-618-01	BUTTON (POWER/T)		85	3-343-248-21	DAMPER (P), SMALL	
* 66	3-929-633-01	ILLUMINATOR		* 86	3-913-467-01	BRACKET (MD)	
* 67	3-929-632-01	HOLDER (LCD)		* 87	3-929-631-01	BRACKET (EJECT)	
* 68	1-660-672-11	SW BOARD		88	3-929-637-01	WINDOW (CASSETTE)	
69	3-929-617-11	BUTTON (BAND/T)		89	3-929-624-01	WINDOW (REMOTE)	
* 70	1-660-668-11	LAMP BOARD		90	3-932-097-01	ENBLLEM (4-A), SONY	
71	1-776-037-11	WIRE, PARALLEL (FFC) (11 CORE)		ND801	1-801-076-11	DISPLAY PANEL, LIQUID CRYSTAL	

8-3. CABINET (UPPER) SECTION

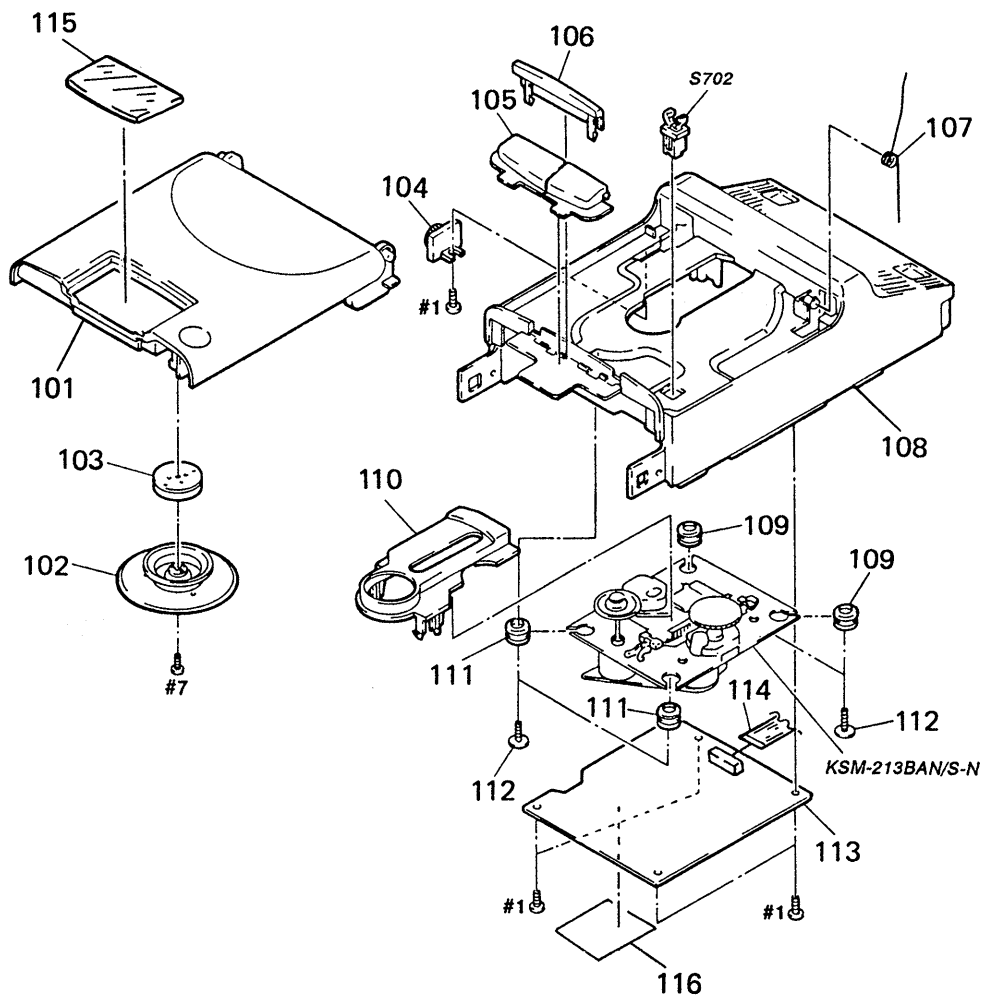

Ref. No.	Part No.	Description	Remark	Ref. No.	Part No.	Description	Remark
* 101	3-929-645-11	LID, CD		110	3-929-731-01	COVER, CD	
102	3-929-730-01	PLATE, CHUCKING		111	3-931-379-31	RUBBER, VIBRATION PROOF	
103	1-452-732-11	MAGNET		112	3-921-725-01	SCREW (2.6X10), +PWH	
104	3-351-377-11	GEAR, DAMPER		* 113	A-3305-443-A	CD MAIN BOARD, COMPLETE	
105	3-929-734-01	BUTTON (CD)		114	1-769-828-11	WIRE (FLAT TYPE) (16 CORE)	
106	3-929-644-01	ESCUTCHEON (CD)		115	3-929-646-01	WINDOW (CD)	
107	3-929-641-01	SPRING (CD-OPEN)		* 116	3-933-727-01	SHIELD (CD) (B)	
108	3-929-642-01	CABINET (UPPER)		S702	1-692-960-11	SWITCH, PUSH (1 KEY) (DOOR OPEN SW)	
109	3-931-379-21	RUBBER, VIBRATION PROOF					

8-4. MECHANISM DECK SECTION (1)
(MF-303-105)

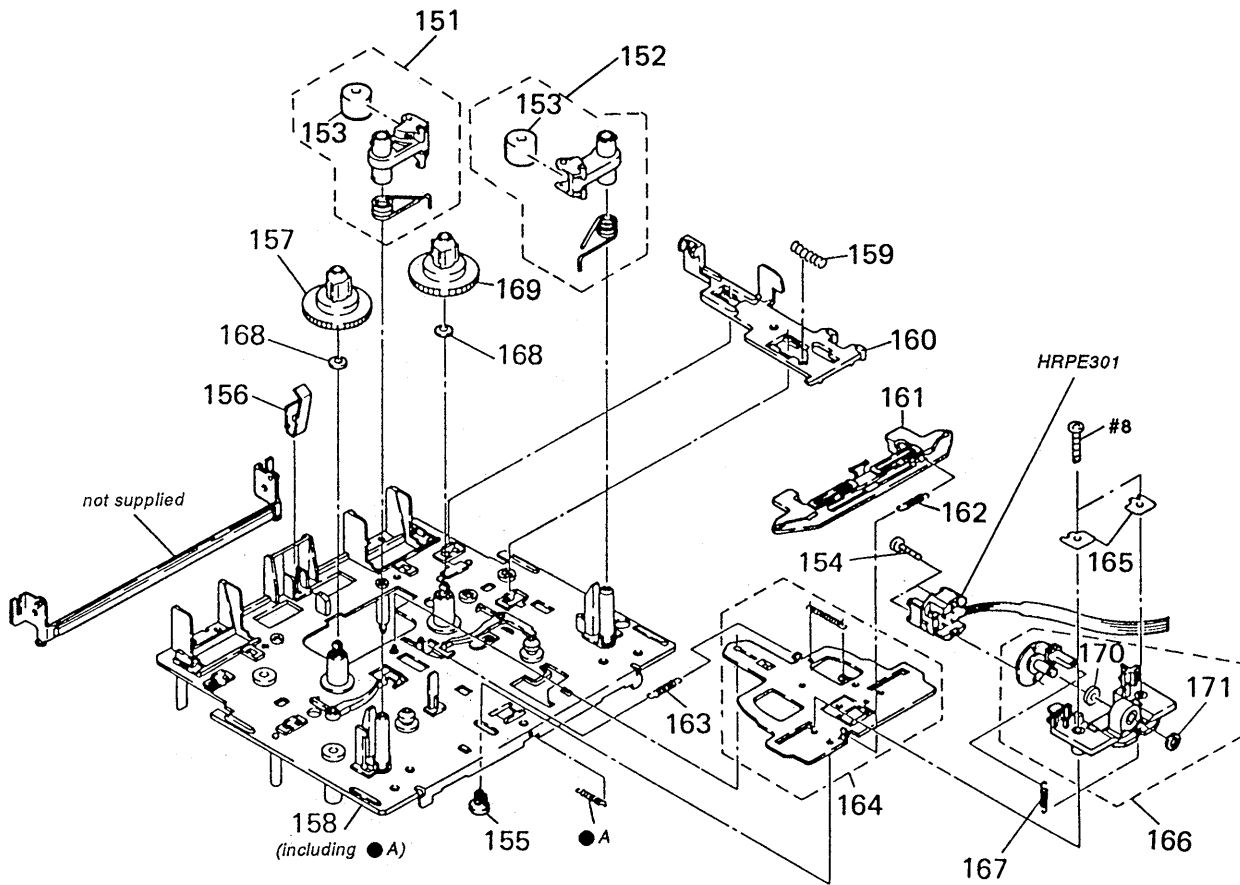

Ref. No.	Part No.	Description	Remark	Ref. No.	Part No.	Description	Remark
151	X-3369-664-1	PINCH LEVER (R) ASSY		* 165	3-384-356-01	SHIM (t=0.3)	
152	X-3369-663-1	PINCH LEVER (N) ASSY		* 165	3-384-356-11	SHIM (t=0.35)	
153	3-366-051-01	PINCH ROLLER		* 165	3-384-356-21	SHIM (t=0.4)	
154	3-316-938-51	SCREW (B1.4X6), TAPPING		* 165	3-384-356-31	SHIM (t=0.45)	
155	3-382-444-01	SCREW (STOPPER)		* 165	3-384-356-41	SHIM (t=0.5)	
156	3-384-106-01	DETENT, CASSETTE		166	X-3368-872-1	GUIDE ASSY (Q), HEAD	
157	X-3367-216-1	GEAR (REEL S) ASSY		167	3-377-663-03	SPRING, TENSION	
* 158	X-3367-461-1	CHASSIS (OUTSERT) ASSY		168	3-906-038-01	WASHER	
159	3-377-670-01	SPRING, COMPRESSION		169	X-3364-791-1	GEAR (REEL) ASSY	
160	3-377-709-21	LEVER (A), EJECT		170	3-701-440-31	WASHER, 3.5	
* 161	3-377-700-01	SLIDER (NR)		171	3-381-362-01	RING, RETAINING	
162	3-377-666-01	SPRING, TENSION		HRPE301	1-543-991-11	HEAD, MAGNETIC (REC/PLAY/ERASE)	
163	3-377-673-01	SPRING, TENSION					
164	X-3364-792-1	BASE ASSY, HEAD					

8-5. MECHANISM DECK SECTION (2)
(MF-303-105)

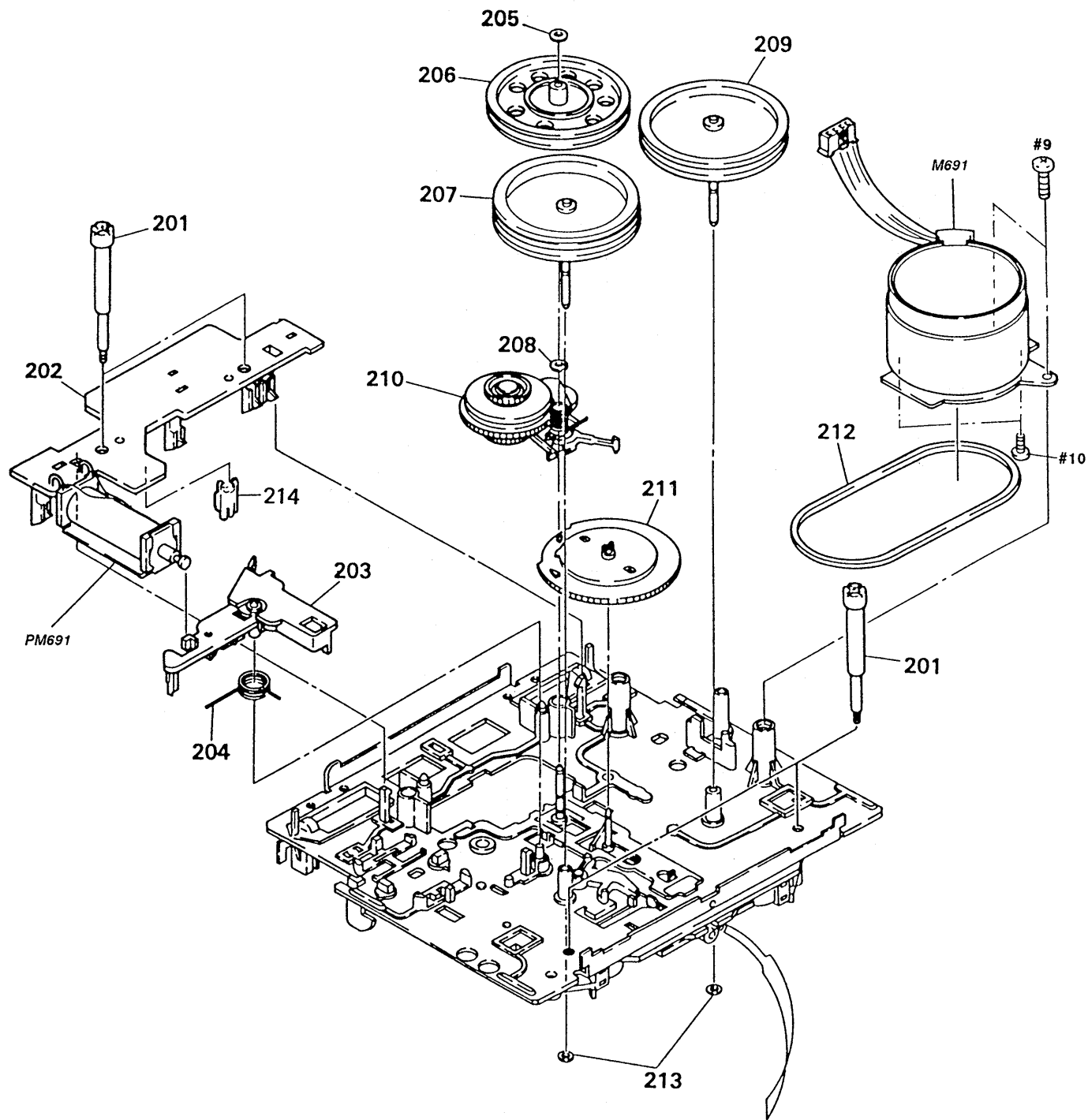

Ref. No.	Part No.	Description	Remark	Ref. No.	Part No.	Description	Remark
* 201	3-377-696-01	SUPPORT		209	X-3365-790-1	FLYWHEEL (R) ASSY	
* 202	1-641-566-21	RELAY BOARD		210	X-3364-793-1	LEVER ASSY, FR	
* 203	3-377-716-01	LEVER, TRIGGER		211	3-377-798-01	GEAR (CAM)	
204	3-377-687-01	SPRING (TRIGGER LEVER), TORSION		212	3-377-688-01	BELT	
205	3-676-387-00	POLY-SLIDER (DIA.1.6)		213	3-343-358-12	RING, RETAINING	
206	3-377-706-01	PULLEY		* 214	3-380-110-01	HOLDER, PHOTO	
207	X-3365-789-1	FLYWHEEL (N) ASSY		M691	A-3263-138-A	MOTOR ASSY (REEL/CAPSTAN)	
208	3-377-664-01	RING, RETAINING		PM691	1-454-595-11	SOLENOID, PLUNGER	

8-6. OPTICAL PICK-UP SECTION
(KSM-213BAN/S-N)

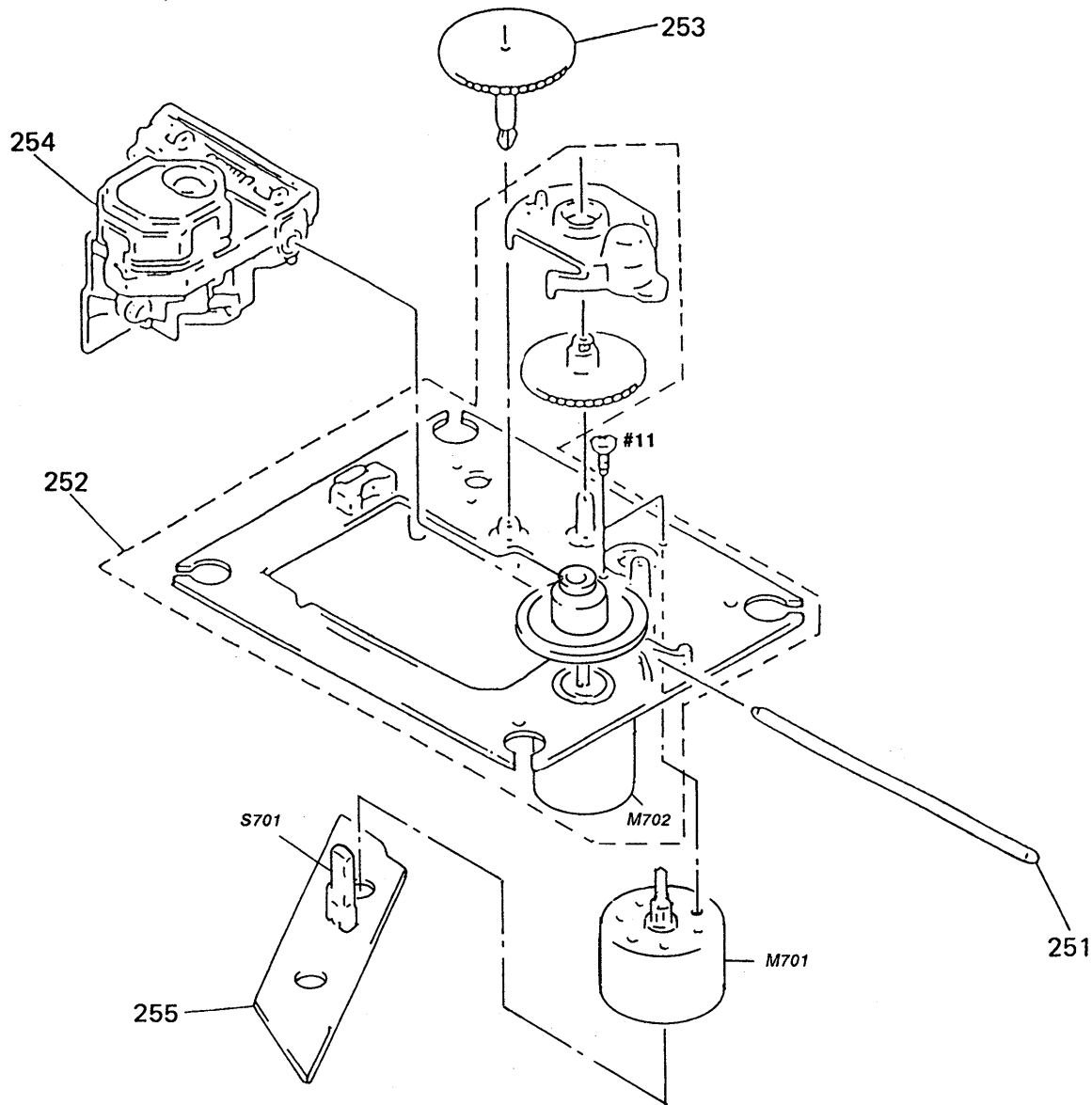

The components identified by mark Δ or dotted line with mark Δ are critical for safety. Replace only with part number specified.

Ref. No.	Part No.	Description	Remark	Ref. No.	Part No.	Description	Remark
251	2-626-908-01	SHAFT, SLED		* 255	1-660-670-11	CD MOTOR BOARD	
252	X-2625-770-1	CHASSIS ASSY, MOTOR (SPINDLE)	(including M702)	M701	X-2625-769-1	GEAR ASSY, MOTOR (SLED)	
253	2-626-907-01	GEAR (A) (S)		S701	1-571-936-11	SWITCH, LEAF (LIMIT SW)	
Δ 254	8-848-367-11	OPTICAL PICK-UP KSS-213B/K-N					

8-7. SPEAKER SECTION

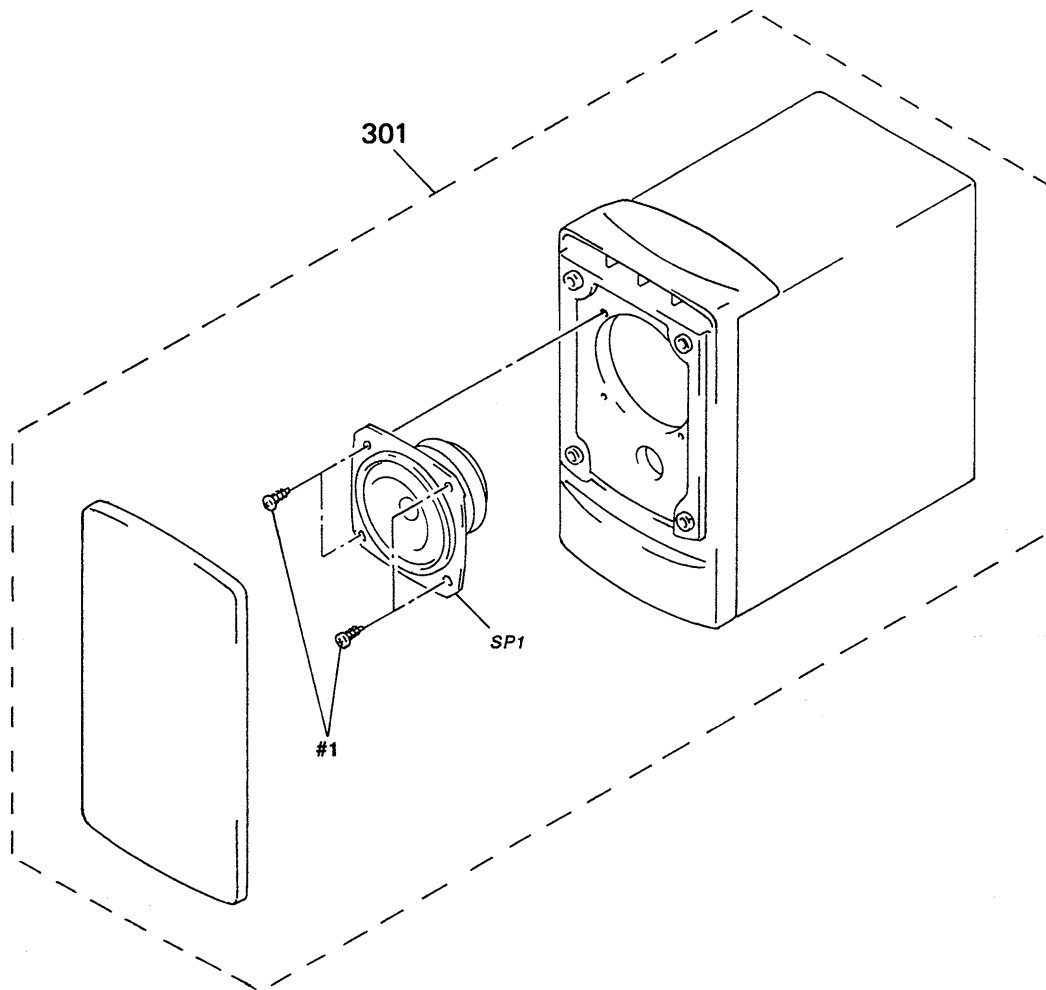

<u>Ref. No.</u>	<u>Part No.</u>	<u>Description</u>	<u>Remark</u>
301	X-3372-655-1	BOX ASSY, SPEAKER (L-CH, R-CH)	
SP1	1-505-382-11	SPEAKER (L-CH, R-CH)	

**SECTION 9
ELECTRICAL PARTS LIST**

NOTE :

- Due to standardization, replacements in the parts list may be different from the parts specified in the diagrams or the components used on the set.
- -XX, -X mean standardized parts, so they may have some difference from the original one.
- RESISTORS
All resistors are in ohms
METAL : Metal-film resistor
METAL OXIDE :Metal oxide-film resistor
F : nonflammable
- Items marked " * " are not stocked since they are seldom required for routine service. Some delay should be anticipated when ordering these items.

● SEMICONDUCTORS

In each case, u : μ , for example :
 uA..... : μ A..... , uPA..... : μ PA.....
 uPB..... : μ PB..... , uPC..... : μ PC.....
 uPD..... : μ PD.....

● CAPACITORS

uF : μ F

● COILS

uH : μ H

The components identified by mark Δ or dotted line with mark Δ are critical for safety.
 Replace only with part number specified.

When indicating parts by reference number, please include the board.

Ref. No.	Part No.	Description	Remark	Ref. No.	Part No.	Description	Remark
*	A-3305-443-A	CD MAIN BOARD, COMPLETE *****		C738	1-162-294-31	CERAMIC	0.001uF 10% 50V
		< CAPACITOR >		C741	1-104-664-11	ELECT	47uF 20% 10V
C700	1-162-306-11	CERAMIC	0.01uF 30% 16V	C742	1-136-173-00	FILM	0.47uF 5% 50V
C701	1-162-302-11	CERAMIC	0.0022uF 30% 16V	C743	1-162-290-31	CERAMIC	470PF 10% 50V
C702	1-136-165-00	FILM	0.1uF 5% 50V	C744	1-162-286-21	CERAMIC	220PF 10% 50V
C703	1-136-165-00	FILM	0.1uF 5% 50V	C745	1-136-169-00	FILM	0.22uF 5% 50V
C704	1-136-165-00	FILM	0.1uF 5% 50V	C746	1-162-306-11	CERAMIC	0.01uF 30% 16V
C705	1-131-375-00	TANTALUM	4.7uF 10% 10V	C747	1-130-483-00	MYLAR	0.01uF 5% 50V
C706	1-130-489-00	MYLAR	0.033uF 5% 50V	C750	1-136-165-00	FILM	0.1uF 5% 50V
C707	1-130-486-00	MYLAR	0.018uF 10% 50V	C752	1-162-199-31	CERAMIC	10PF 5% 50V
C708	1-162-199-31	CERAMIC	10PF 5% 50V	C753	1-162-199-31	CERAMIC	10PF 5% 50V
C709	1-126-962-11	ELECT	3.3uF 20% 50V	C754	1-104-666-11	ELECT	220uF 20% 10V
C710	1-130-493-00	MYLAR	0.068uF 5% 50V	C755	1-136-165-00	FILM	0.1uF 5% 50V
C711	1-162-215-31	CERAMIC	47PF 5% 50V	C756	1-162-306-11	CERAMIC	0.01uF 30% 16V
C712	1-162-306-11	CERAMIC	0.01uF 30% 16V	C758	1-162-306-11	CERAMIC	0.01uF 30% 16V
C713	1-130-489-00	MYLAR	0.033uF 5% 50V	C759	1-136-165-00	FILM	0.1uF 5% 50V
C714	1-162-306-11	CERAMIC	0.01uF 30% 16V	C760	1-104-666-11	ELECT	220uF 20% 10V
C715	1-130-489-00	MYLAR	0.033uF 5% 50V	C761	1-162-290-31	CERAMIC	470PF 10% 50V
C716	1-136-169-00	FILM	0.22uF 5% 50V	C762	1-162-282-31	CERAMIC	100PF 10% 50V
C717	1-104-664-11	ELECT	47uF 20% 10V	C763	1-162-600-11	CERAMIC	0.0047uF 30% 16V
C718	1-124-907-11	ELECT	10uF 20% 50V	C764	1-126-963-11	ELECT	4.7uF 20% 50V
C719	1-162-282-31	CERAMIC	100PF 10% 50V	C773	1-162-600-11	CERAMIC	0.0047uF 30% 16V
C721	1-130-491-00	MYLAR	0.047uF 5% 50V	C774	1-126-963-11	ELECT	4.7uF 20% 50V
C722	1-161-494-00	CERAMIC	0.022uF 25V	C780	1-162-306-11	CERAMIC	0.01uF 30% 16V
C723	1-136-165-00	FILM	0.1uF 5% 50V	C781	1-104-666-11	ELECT	220uF 20% 10V
C725	1-162-199-31	CERAMIC	10PF 5% 50V	C782	1-162-294-31	CERAMIC	0.001uF 10% 50V
C726	1-162-294-31	CERAMIC	0.001uF 10% 50V	C783	1-162-306-11	CERAMIC	0.01uF 30% 16V
C727	1-162-306-11	CERAMIC	0.01uF 30% 16V	C784	1-130-491-00	MYLAR	0.047uF 5% 50V
C728	1-164-159-21	CERAMIC	0.1uF 50V	C786	1-162-294-31	CERAMIC	0.001uF 10% 50V
C729	1-104-666-11	ELECT	220uF 20% 6.3V	C787	1-124-442-00	ELECT	330uF 20% 6.3V
C730	1-124-473-11	ELECT	1000uF 20% 10V	C788	1-162-306-11	CERAMIC	0.01uF 30% 16V
C731	1-162-294-31	CERAMIC	0.001uF 10% 50V	C790	1-124-902-00	ELECT	0.47uF 20% 50V
C732	1-130-484-00	MYLAR	0.012uF 5% 50V	C792	1-162-282-31	CERAMIC	100PF 10% 50V
C734	1-162-305-11	CERAMIC	0.0068uF 30% 16V	C793	1-162-282-31	CERAMIC	100PF 10% 50V
C737	1-162-294-31	CERAMIC	0.001uF 10% 50V	C794	1-162-282-31	CERAMIC	100PF 10% 50V
				C795	1-162-294-31	CERAMIC	0.001uF 10% 50V
				C796	1-162-306-11	CERAMIC	0.01uF 30% 16V

Ref. No.	Part No.	Description	Remark
C797	1-162-282-31	CERAMIC 100PF 10% 50V	
< CONNECTOR >			
CN701	1-770-168-11	CONNECTOR, FFC/FPC 16P	
* CN704	1-566-005-11	PIN, CONNECTOR (PC BOARD) 8P	
CN706	1-695-372-31	PIN, CONNECTOR (PC BOARD) 11P	
< DIODE >			
D702	8-719-991-33	DIODE 1SS133T-77	
D703	8-719-991-33	DIODE 1SS133T-77	
< IC >			
IC701	8-752-069-56	IC CXA1782BQ	
IC702	8-752-372-94	IC CXD2507AQ	
IC703	8-759-336-75	IC BA5930FP	
IC704	8-759-364-34	IC SM5877AM	
< JUMPER RESISTOR >			
JW745	1-249-417-11	CARBON 1K 5% 1/4W	
JW748	1-249-417-11	CARBON 1K 5% 1/4W	
JW761	1-162-294-31	CERAMIC 0.001uF 10% 50V	
JW762	1-414-142-11	INDUCTOR 1UH	
JW770	1-410-513-11	INDUCTOR 22UH	
< COIL >			
L702	1-414-146-31	INDUCTOR 2.2uH	
L703	1-414-146-31	INDUCTOR 2.2uH	
L704	1-410-397-21	FERRITE BEAD INDUCTOR	
L705	1-410-397-21	FERRITE BEAD INDUCTOR	
L713	1-410-397-21	FERRITE BEAD INDUCTOR	
L715	1-410-397-21	FERRITE BEAD INDUCTOR	
L716	1-249-417-11	CARBON 1K 5% 1/4W	
L717	1-249-417-11	CARBON 1K 5% 1/4W	
L718	1-249-417-11	CARBON 1K 5% 1/4W	
L719	1-249-417-11	CARBON 1K 5% 1/4W	
L720	1-249-417-11	CARBON 1K 5% 1/4W	
L721	1-249-417-11	CARBON 1K 5% 1/4W	
L722	1-249-417-11	CARBON 1K 5% 1/4W	
L724	1-410-509-11	INDUCTOR 10uH	
L760	1-410-513-11	INDUCTOR 22uH	
L770	1-410-513-11	INDUCTOR 22uH	
< TRANSISTOR >			
Q701	8-729-801-84	TRANSISTOR 2SB1013-4	
Q702	8-729-900-85	TRANSISTOR DTC144WS	
Q703	8-729-900-74	TRANSISTOR DTC143TS	
Q705	8-729-902-80	TRANSISTOR DTA114YS	
Q760	8-729-900-74	TRANSISTOR DTC143TS	
Q770	8-729-900-74	TRANSISTOR DTC143TS	

Ref. No.	Part No.	Description	Remark
< RESISTOR >			
R700	1-249-429-11	CARBON 10K 5% 1/4W	
R701	1-249-441-11	CARBON 100K 5% 1/4W	
R702	1-247-896-11	CARBON 510K 5% 1/4W	
R703	1-249-441-11	CARBON 100K 5% 1/4W	
R704	1-247-883-00	CARBON 150K 5% 1/4W	
R705	1-249-437-11	CARBON 47K 5% 1/4W	
R706	1-247-876-11	CARBON 75K 5% 1/4W	
R707	1-249-432-11	CARBON 18K 5% 1/4W	
R708	1-247-883-00	CARBON 150K 5% 1/4W	
R709	1-247-862-11	CARBON 20K 5% 1/4W	
R710	1-249-393-11	CARBON 10 5% 1/4W	
R714	1-247-883-00	CARBON 150K 5% 1/4W	
R716	1-249-430-11	CARBON 12K 5% 1/4W	
R717	1-249-429-11	CARBON 10K 5% 1/4W	
R718	1-247-899-11	CARBON 680K 5% 1/4W	
R720	1-247-891-00	CARBON 330K 5% 1/4W	
R722	1-249-439-11	CARBON 68K 5% 1/4W	
R723	1-249-440-11	CARBON 82K 5% 1/4W	
R725	1-249-437-11	CARBON 47K 5% 1/4W	
R726	1-249-429-11	CARBON 10K 5% 1/4W	
R727	1-249-429-11	CARBON 10K 5% 1/4W	
R730	1-249-435-11	CARBON 33K 5% 1/4W	
R731	1-247-863-11	CARBON 22K 5% 1/4W	
R732	1-249-429-11	CARBON 10K 5% 1/4W	
R733	1-249-435-11	CARBON 33K 5% 1/4W	
R734	1-249-437-11	CARBON 47K 5% 1/4W	
R735	1-249-425-11	CARBON 4.7K 5% 1/4W	
R736	1-249-429-11	CARBON 10K 5% 1/4W	
R737	1-249-429-11	CARBON 10K 5% 1/4W	
R738	1-249-429-11	CARBON 10K 5% 1/4W	
R740	1-247-843-11	CARBON 3.3K 5% 1/4W	
R741	1-249-417-11	CARBON 1K 5% 1/4W	
R742	1-249-429-11	CARBON 10K 5% 1/4W	
R743	1-247-903-00	CARBON 1M 5% 1/4W	
R744	1-247-887-00	CARBON 220K 5% 1/4W	
R745	1-249-429-11	CARBON 10K 5% 1/4W	
R746	1-249-437-11	CARBON 47K 5% 1/4W	
R747	1-249-417-11	CARBON 1K 5% 1/4W	
R748	1-249-429-11	CARBON 10K 5% 1/4W	
R749	1-249-429-11	CARBON 10K 5% 1/4W	
R750	1-249-417-11	CARBON 1K 5% 1/4W	
R753	1-249-429-11	CARBON 10K 5% 1/4W	
R755	1-249-429-11	CARBON 10K 5% 1/4W	
R756	1-249-440-11	CARBON 82K 5% 1/4W	
R757	1-249-439-11	CARBON 68K 5% 1/4W	
R758	1-249-439-11	CARBON 68K 5% 1/4W	
R759	1-249-439-11	CARBON 68K 5% 1/4W	
R766	1-249-417-11	CARBON 1K 5% 1/4W	
R776	1-249-417-11	CARBON 1K 5% 1/4W	
R777	1-249-417-11	CARBON 1K 5% 1/4W	

CD MAIN

CD MOTOR

DIODE

DISPLAY

Ref. No.	Part No.	Description	Remark
R778	1-249-417-11	CARBON 1K 5%	1/4W
R779	1-249-417-11	CARBON 1K 5%	1/4W
R780	1-249-417-11	CARBON 1K 5%	1/4W
R781	1-249-417-11	CARBON 1K 5%	1/4W
R782	1-249-417-11	CARBON 1K 5%	1/4W
< VARIABLE RESISTOR >			
R790	1-247-863-11	CARBON 22K 5%	1/4W
R791	1-249-431-11	CARBON 15K 5%	1/4W
R792	1-249-429-11	CARBON 10K 5%	1/4W
< VIBRATOR >			
X701	1-579-345-11	VIBRATOR, CERAMIC (16.934MHz)	

*	1-660-670-11	CD MOTOR BOARD *****	
< CONNECTOR >			
* CN707	1-566-003-11	PIN, CONNECTOR (PC BOARD) 6P BOARD	

*	A-3305-719-A	DIODE BOARD, COMPLETE *****	
	1-533-313-11	HOLDER, FUSE	
< CAPACITOR >			
C901	1-136-157-00	FILM 0.022uF 5%	50V
C902	1-136-157-00	FILM 0.022uF 5%	50V
C903	1-136-157-00	FILM 0.022uF 5%	50V
C904	1-136-157-00	FILM 0.022uF 5%	50V
C905	1-136-165-00	FILM 0.1uF 5%	50V
C906	1-162-282-31	CERAMIC 100PF 10%	50V
< CONNECTOR >			
CN906	1-564-320-00	PIN, CONNECTOR (B2P-VH) 2P	
CN907	1-569-596-11	PLUG, CONNECTOR (2.5MM) 3P	
< DIODE >			
D901	8-719-302-38	DIODE RBV-602-01	
D905	8-719-991-33	DIODE 1SS133T-77	
D906	8-719-991-33	DIODE 1SS133T-77	
< FUSE >			
△F901	1-533-472-11	FUSE, GLASS TUBE (DIA. 5)(5A/250V)	
< RESISTOR >			
R901	1-249-417-11	CARBON 1K 5%	1/4W

Ref. No.	Part No.	Description	Remark
*	A-3305-714-A	DISPLAY BOARD, COMPLETE *****	
*	3-929-632-01	HOLDER (LCD)	
*	3-929-633-01	ILLUMINATOR	
*	3-932-100-01	PLATE (DISPLAY) (A), SHIELD	
< CAPACITOR >			
C801	1-164-232-11	CERAMIC CHIP 0.01uF	50V
C802	1-126-096-11	ELECT 10uF	20% 35V
C803	1-126-157-11	ELECT 10uF	20% 16V
C804	1-164-232-11	CERAMIC CHIP 0.01uF	50V
C805	1-110-654-11	CAP, DOUBLE LAER 0.047F	
C806	1-163-237-11	CERAMIC CHIP 27PF	5% 50V
C807	1-163-237-11	CERAMIC CHIP 27PF	5% 50V
C808	1-164-232-11	CERAMIC CHIP 0.01uF	50V
C809	1-164-232-11	CERAMIC CHIP 0.01uF	50V
C810	1-164-232-11	CERAMIC CHIP 0.01uF	50V
C811	1-163-237-11	CERAMIC CHIP 27PF	5% 50V
C812	1-163-237-11	CERAMIC CHIP 27PF	5% 50V
C813	1-164-232-11	CERAMIC CHIP 0.01uF	50V
C814	1-163-117-00	CERAMIC CHIP 100PF	5% 50V
C815	1-163-117-00	CERAMIC CHIP 100PF	5% 50V
C816	1-163-117-00	CERAMIC CHIP 100PF	5% 50V
C817	1-163-117-00	CERAMIC CHIP 100PF	5% 50V
C819	1-164-232-11	CERAMIC CHIP 0.01uF	50V
C820	1-163-239-11	CERAMIC CHIP 33PF	5% 50V
C821	1-163-239-11	CERAMIC CHIP 33PF	5% 50V
C822	1-164-232-11	CERAMIC CHIP 0.01uF	50V
C823	1-126-157-11	ELECT 10uF	20% 16V
C824	1-164-232-11	CERAMIC CHIP 0.01uF	50V
C825	1-164-232-11	CERAMIC CHIP 0.01uF	50V
C826	1-164-232-11	CERAMIC CHIP 0.01uF	50V
C827	1-164-232-11	CERAMIC CHIP 0.01uF	50V
C828	1-164-232-11	CERAMIC CHIP 0.01uF	50V
C829	1-164-232-11	CERAMIC CHIP 0.01uF	50V
C830	1-164-232-11	CERAMIC CHIP 0.01uF	50V
C831	1-163-117-00	CERAMIC CHIP 100PF	5% 50V
C832	1-163-125-00	CERAMIC CHIP 220PF	5% 50V
C833	1-163-125-00	CERAMIC CHIP 220PF	5% 50V
C834	1-163-181-00	CERAMIC CHIP 100PF	5% 50V
C835	1-163-181-00	CERAMIC CHIP 100PF	5% 50V
C836	1-163-181-00	CERAMIC CHIP 100PF	5% 50V
C837	1-163-125-00	CERAMIC CHIP 220PF	5% 50V
C838	1-163-125-00	CERAMIC CHIP 220PF	5% 50V
C839	1-163-125-00	CERAMIC CHIP 220PF	5% 50V
C840	1-163-125-00	CERAMIC CHIP 220PF	5% 50V
C841	1-163-125-00	CERAMIC CHIP 220PF	5% 50V
C842	1-163-117-00	CERAMIC CHIP 100PF	5% 50V
C843	1-163-181-00	CERAMIC CHIP 100PF	5% 50V
C844	1-164-232-11	CERAMIC CHIP 0.01uF	50V
C845	1-164-232-11	CERAMIC CHIP 0.01uF	50V
C846	1-164-232-11	CERAMIC CHIP 0.01uF	50V

The components identified by mark △ or dotted line with mark △ are critical for safety.
Replace only with part number specified.

Ref. No.	Part No.	Description	Remark	Ref. No.	Part No.	Description	Remark
C847	1-163-117-00	CERAMIC CHIP	100PF 5% 50V				
C848	1-163-117-00	CERAMIC CHIP	100PF 5% 50V				
C849	1-163-117-00	CERAMIC CHIP	100PF 5% 50V				
C850	1-164-232-11	CERAMIC CHIP	0.01uF 50V				
C851	1-126-157-11	ELECT	10uF 20% 16V				
C965	1-162-306-11	CERAMIC	0.01uF 30% 16V				
< CONNECTOR >							
CN801	1-695-368-31	CONNECTOR, FFC/FPC 7P					
CN802	1-770-520-31	CONNECTOR, FFC/FPC 12P					
CN803	1-695-376-11	CONNECTOR, FFC/FPC 15P					
CN804	1-770-519-31	CONNECTOR, FFC/FPC 11P					
CN805	1-774-460-11	CONNECTOR, BOARD TO BOARD 10P					
CN808	1-569-614-11	PLUG, CONNECTOR (2.5MM) 2P					
< DIODE >							
D801	8-719-914-44	DIODE DAP202K					
D802	8-719-976-96	DIODE DTZ4.7C					
< IC >							
IC801	8-752-876-32	IC CXP83124A-011Q					
IC802	8-759-604-02	IC M5278L56					
IC803	8-759-510-61	IC S80735AL-AZ-S					
< JUMPER RESISTOR >							
JC801	1-216-296-00	METAL CHIP	0 5% 1/8W				
JC804	1-216-296-00	METAL CHIP	0 5% 1/8W				
JC805	1-216-296-00	METAL CHIP	0 5% 1/8W				
JC808	1-216-296-00	METAL CHIP	0 5% 1/8W				
JC809	1-216-295-00	METAL CHIP	0 5% 1/10W				
JC811	1-216-295-00	METAL CHIP	0 5% 1/10W				
JC812	1-216-296-00	METAL CHIP	0 5% 1/8W				
JC813	1-216-296-00	METAL CHIP	0 5% 1/8W				
JC814	1-216-295-00	METAL CHIP	0 5% 1/10W				
< COIL >							
L801	1-414-196-41	INDUCTOR	47uH				
< LIQUID CRYSTAL DISPLAY >							
ND801	1-801-076-11	DISPLAY PANEL, LIQUID CRYSTAL					
< TRANSISTOR >							
Q101	8-729-920-31	TRANSISTOR DTC343TK					
Q201	8-729-920-31	TRANSISTOR DTC343TK					
Q801	8-729-901-46	TRANSISTOR DTA114YK					
Q802	8-729-900-52	TRANSISTOR DTC114YK					
Q804	8-729-931-02	TRANSISTOR 2SC2413KQ					
Q805	8-729-931-02	TRANSISTOR 2SC2413KQ					
< RESISTOR >							
R118	1-216-021-00	METAL CHIP	68 5% 1/10W				
R218	1-216-021-00	METAL CHIP	68 5% 1/10W				
R801	1-216-089-00	METAL GLAZE	47K 5% 1/10W				
R802	1-216-049-11	METAL GLAZE	1K 5% 1/10W				
R805	1-216-073-00	METAL CHIP	10K 5% 1/10W				
R806	1-216-222-00	METAL GLAZE	10K 5% 1/8W				
R807	1-216-222-00	METAL GLAZE	10K 5% 1/8W				
R808	1-216-073-00	METAL CHIP	10K 5% 1/10W				
R809	1-216-049-11	METAL GLAZE	1K 5% 1/10W				
R810	1-216-073-00	METAL CHIP	10K 5% 1/10W				
R811	1-216-073-00	METAL CHIP	10K 5% 1/10W				
R812	1-216-073-00	METAL CHIP	10K 5% 1/10W				
R813	1-216-073-00	METAL CHIP	10K 5% 1/10W				
R814	1-216-073-00	METAL CHIP	10K 5% 1/10W				
R815	1-216-073-00	METAL CHIP	10K 5% 1/10W				
R816	1-216-049-11	METAL GLAZE	1K 5% 1/10W				
R817	1-216-049-11	METAL GLAZE	1K 5% 1/10W				
R818	1-216-049-11	METAL GLAZE	1K 5% 1/10W				
R820	1-216-222-00	METAL GLAZE	10K 5% 1/8W				
R822	1-216-198-00	METAL GLAZE	1K 5% 1/8W				
R823	1-216-049-11	METAL GLAZE	1K 5% 1/10W				
R824	1-216-049-11	METAL GLAZE	1K 5% 1/10W				
R826	1-216-073-00	METAL CHIP	10K 5% 1/10W				
R827	1-216-073-00	METAL CHIP	10K 5% 1/10W				
R828	1-216-049-11	METAL GLAZE	1K 5% 1/10W				
R829	1-216-049-11	METAL GLAZE	1K 5% 1/10W				
R831	1-216-049-11	METAL GLAZE	1K 5% 1/10W				
R832	1-216-073-00	METAL CHIP	10K 5% 1/10W				
R833	1-216-049-11	METAL GLAZE	1K 5% 1/10W				
R834	1-216-198-00	METAL GLAZE	1K 5% 1/8W				
R835	1-216-198-00	METAL GLAZE	1K 5% 1/8W				
R836	1-216-198-00	METAL GLAZE	1K 5% 1/8W				
R837	1-216-198-00	METAL GLAZE	1K 5% 1/8W				
R838	1-216-198-00	METAL GLAZE	1K 5% 1/8W				
R839	1-216-073-00	METAL CHIP	10K 5% 1/10W				
R840	1-216-073-00	METAL CHIP	10K 5% 1/10W				
R841	1-216-073-00	METAL CHIP	10K 5% 1/10W				
R842	1-216-073-00	METAL CHIP	10K 5% 1/10W				
R843	1-216-073-00	METAL CHIP	10K 5% 1/10W				
R844	1-216-073-00	METAL CHIP	10K 5% 1/10W				
R845	1-216-073-00	METAL CHIP	10K 5% 1/10W				
R846	1-216-073-00	METAL CHIP	10K 5% 1/10W				
R847	1-216-073-00	METAL CHIP	10K 5% 1/10W				
R848	1-216-073-00	METAL CHIP	10K 5% 1/10W				
R849	1-216-073-00	METAL CHIP	10K 5% 1/10W				
R850	1-216-073-00	METAL CHIP	10K 5% 1/10W				
R851	1-216-049-11	METAL GLAZE	1K 5% 1/10W				
R852	1-216-049-11	METAL GLAZE	1K 5% 1/10W				
R853	1-216-049-11	METAL GLAZE	1K 5% 1/10W				
R854	1-216-049-11	METAL GLAZE	1K 5% 1/10W				

DISPLAY **FILTER** **LAMP** **MAIN**

Ref. No.	Part No.	Description	Remark
R856	1-216-049-11	METAL GLAZE 1K	5% 1/10W
R858	1-216-037-00	METAL CHIP 330	5% 1/10W
R860	1-216-080-00	METAL CHIP 20K	5% 1/10W
R861	1-216-073-00	METAL CHIP 10K	5% 1/10W
R862	1-216-073-00	METAL CHIP 10K	5% 1/10W
R863	1-216-089-00	METAL GLAZE 47K	5% 1/10W
R864	1-216-073-00	METAL CHIP 10K	5% 1/10W
R866	1-216-089-00	METAL GLAZE 47K	5% 1/10W
R867	1-216-025-00	METAL GLAZE 100	5% 1/10W
R868	1-216-047-00	METAL GLAZE 820	5% 1/10W
R869	1-216-049-11	METAL GLAZE 1K	5% 1/10W
R870	1-216-045-00	METAL CHIP 680	5% 1/10W
R871	1-216-073-00	METAL CHIP 10K	5% 1/10W
R872	1-216-065-00	METAL CHIP 4.7K	5% 1/10W
R873	1-216-089-00	METAL GLAZE 47K	5% 1/10W
R874	1-216-089-00	METAL GLAZE 47K	5% 1/10W
R875	1-216-045-00	METAL CHIP 680	5% 1/10W
R876	1-216-073-00	METAL CHIP 10K	5% 1/10W
< SWITCH >			
S817	1-554-088-00	SWITCH, KEY BOARD (◀◀◀)	
S818	1-554-088-00	SWITCH, KEY BOARD (▶▶▶)	
< VIBRATOR >			
X801	1-760-105-11	VIBRATOR, CRYSTAL (32.76kHz)	
X802	1-577-273-11	OSCILLATOR, CERAMIC (4.19MHz)	

* 1-660-671-11 FILTER BOARD			

< CONNECTOR >			
CN901	1-564-321-00	PIN, CONNECTOR 2P	
* CN902	1-564-321-21	PIN, CONNECTOR 2P	
< LINE FILTER >			
△ LF901	1-402-663-11	TRANSFORMER, LINE FILTER (LFT)	

* 1-660-668-11 LAMP BOARD			

< PILOT LAMP >			
PL801	1-517-487-11	LAMP, PILOT (BACK LIGHT)	
PL802	1-517-487-11	LAMP, PILOT (BACK LIGHT)	
PL803	1-517-487-11	LAMP, PILOT (BACK LIGHT)	
PL804	1-517-487-11	LAMP, PILOT (BACK LIGHT)	

Ref. No.	Part No.	Description	Remark
*	A-3305-716-A	MAIN BOARD, COMPLETE	*****
< BUZZER >			
BZ501	1-529-080-11	BUZZER, PIEZOELECTRIC	
< CAPACITOR >			
C1	1-162-306-11	CERAMIC 0.01uF	30% 16V
C2	1-162-306-11	CERAMIC 0.01uF	30% 16V
C3	1-162-281-31	CERAMIC 91PF	10% 50V
C4	1-162-306-11	CERAMIC 0.01uF	30% 16V
C5	1-162-306-11	CERAMIC 0.01uF	30% 16V
C6	1-161-494-00	CERAMIC 0.022uF	25V
C7	1-162-851-11	CERAMIC 0.1uF	16V
C8	1-136-165-00	FILM 0.1uF	5% 50V
C9	1-162-282-31	CERAMIC 100PF	10% 50V
C10	1-130-468-00	MYLAR 560PF	5% 50V
C11	1-162-194-31	CERAMIC 3.9PF	10% 50V
C12	1-130-467-00	MYLAR 470PF	5% 50V
C13	1-162-306-11	CERAMIC 0.01uF	30% 16V
C14	1-162-851-11	CERAMIC 0.1uF	16V
C15	1-162-306-11	CERAMIC 0.01uF	30% 16V
C16	1-126-963-11	ELECT 4.7uF	20% 50V
C17	1-162-288-31	CERAMIC 330PF	10% 50V
C18	1-162-600-11	CERAMIC 0.0047uF	30% 16V
C19	1-124-907-11	ELECT 10uF	20% 50V
C20	1-161-061-11	CERAMIC 0.068uF	10% 50V
C21	1-161-024-00	CERAMIC 0.082uF	10% 25V
C22	1-161-024-00	CERAMIC 0.082uF	10% 25V
C23	1-161-053-00	CERAMIC 0.015uF	10% 50V
C24	1-161-053-00	CERAMIC 0.015uF	10% 50V
C25	1-162-306-11	CERAMIC 0.01uF	30% 16V
C26	1-162-306-11	CERAMIC 0.01uF	30% 16V
C27	1-124-443-00	ELECT 100uF	20% 10V
C28	1-102-518-11	CERAMIC 33PF	5% 50V
C29	1-162-199-31	CERAMIC 10PF	5% 50V
C30	1-162-306-11	CERAMIC 0.01uF	30% 16V
C31	1-162-306-11	CERAMIC 0.01uF	30% 16V
C32	1-162-306-11	CERAMIC 0.01uF	30% 16V
C33	1-162-306-11	CERAMIC 0.01uF	30% 16V
C34	1-162-294-31	CERAMIC 0.001uF	10% 50V
C35	1-162-294-31	CERAMIC 0.001uF	10% 50V
C36	1-162-294-31	CERAMIC 0.001uF	10% 50V
C37	1-124-907-11	ELECT 10uF	20% 50V
C38	1-162-306-11	CERAMIC 0.01uF	30% 16V
C39	1-124-907-11	ELECT 10uF	20% 50V
C40	1-162-306-11	CERAMIC 0.01uF	30% 16V
C41	1-136-177-00	FILM 1uF	5% 50V
C42	1-130-483-00	MYLAR 0.01uF	5% 50V
C44	1-124-903-11	ELECT 1uF	20% 50V
C45	1-124-903-11	ELECT 1uF	20% 50V
C46	1-124-907-11	ELECT 10uF	20% 50V

The components identified by mark △ or dotted line with mark △ are critical for safety.
Replace only with part number specified.

MAIN

Ref. No.	Part No.	Description	Remark	Ref. No.	Part No.	Description	Remark
		< DIODE >					
D1	8-719-991-33	DIODE 1SS133T-77		Q503	8-729-904-36	TRANSISTOR DTC114YS	
D2	8-719-991-33	DIODE 1SS133T-77		Q504	8-729-904-36	TRANSISTOR DTC114YS	
D5	8-719-976-30	DIODE KV1560N		Q957	8-729-801-84	TRANSISTOR 2SB1013-4	
		< IC >		Q958	8-729-901-57	TRANSISTOR DTC143XS	
IC1	8-759-386-02	IC TA2008AN				< RESISTOR >	
IC2	8-759-290-61	IC BU2615S		R1	1-249-406-11	CARBON 120 5% 1/4W	
IC350	8-752-057-20	IC CXA1102P		R2	1-247-807-31	CARBON 100 5% 1/4W	
IC352	8-759-370-75	IC NJM2123D		R3	1-249-425-11	CARBON 4.7K 5% 1/4W	
IC355	8-759-602-67	IC M5278L05		R4	1-249-425-11	CARBON 4.7K 5% 1/4W	
		< COIL >		R5	1-249-416-11	CARBON 820 5% 1/4W	
L2	1-409-936-11	COIL, MW RF		R6	1-249-425-11	CARBON 4.7K 5% 1/4W	
L3	1-409-937-11	COIL, LW RF		R7	1-249-425-11	CARBON 4.7K 5% 1/4W	
L4	1-406-385-11	COIL (OSC)		R8	1-249-414-11	CARBON 560 5% 1/4W	
L5	1-410-336-11	INDUCTOR 220uH		R9	1-249-417-11	CARBON 1K 5% 1/4W	
L6	1-410-336-11	INDUCTOR 220uH		R10	1-249-429-11	CARBON 10K 5% 1/4W	
L8	1-414-142-11	INDUCTOR 1uH		R11	1-247-887-00	CARBON 220K 5% 1/4W	
L9	1-410-065-11	INDUCTOR 3.3mH		R12	1-249-425-11	CARBON 4.7K 5% 1/4W	
L10	1-414-142-11	INDUCTOR 1uH		R13	1-249-437-11	CARBON 47K 5% 1/4W	
L12	1-233-306-31	ENCAPSULATED COMPONENT		R14	1-247-863-11	CARBON 22K 5% 1/4W	
L502	1-410-521-11	INDUCTOR 100uH		R15	1-249-407-11	CARBON 150 5% 1/4W	
		< IC LINK >		R16	1-249-437-11	CARBON 47K 5% 1/4W	
△PS954	1-532-605-00	LINK, IC 0.4A		R17	1-249-400-11	CARBON 39 5% 1/4W	
		< TRANSISTOR >		R18	1-249-413-11	CARBON 470 5% 1/4W	
Q1	8-729-905-50	TRANSISTOR DTC343TS		R19	1-249-421-11	CARBON 2.2K 5% 1/4W	
Q2	8-729-905-50	TRANSISTOR DTC343TS		R20	1-247-863-11	CARBON 22K 5% 1/4W	
Q3	8-729-922-66	TRANSISTOR 2SC2410SN		R21	1-249-406-11	CARBON 120 5% 1/4W	
Q4	8-729-922-66	TRANSISTOR 2SC2410SN		R22	1-249-429-11	CARBON 10K 5% 1/4W	
Q5	8-729-178-62	TRANSISTOR 2SC2786-L		R23	1-249-429-11	CARBON 10K 5% 1/4W	
Q6	8-729-119-32	TRANSISTOR 2SK193		R24	1-249-429-11	CARBON 10K 5% 1/4W	
Q7	8-729-922-66	TRANSISTOR 2SC2410SN		R25	1-249-429-11	CARBON 10K 5% 1/4W	
Q9	8-729-904-36	TRANSISTOR DTC114YS		R26	1-249-417-11	CARBON 1K 5% 1/4W	
Q10	8-729-904-36	TRANSISTOR DTC114YS		R27	1-249-417-11	CARBON 1K 5% 1/4W	
Q11	8-729-900-89	TRANSISTOR DTC144ES		R28	1-249-429-11	CARBON 10K 5% 1/4W	
Q12	8-729-904-36	TRANSISTOR DTC114YS		R29	1-249-429-11	CARBON 10K 5% 1/4W	
Q13	8-729-012-83	TRANSISTOR 2SK679A		R30	1-249-421-11	CARBON 2.2K 5% 1/4W	
Q15	8-729-904-36	TRANSISTOR DTC114YS		R31	1-249-425-11	CARBON 4.7K 5% 1/4W	
Q16	8-729-904-36	TRANSISTOR DTC114YS		R32	1-249-431-11	CARBON 15K 5% 1/4W	
Q17	8-729-904-34	TRANSISTOR DTA114TS		R34	1-249-415-11	CARBON 680 5% 1/4W	
Q18	8-729-422-57	TRANSISTOR UN4111		R35	1-249-412-11	CARBON 390 5% 1/4W	
Q19	8-729-900-80	TRANSISTOR DTC114ES		R36	1-249-437-11	CARBON 47K 5% 1/4W	
Q21	8-729-422-57	TRANSISTOR UN4111		R37	1-249-417-11	CARBON 1K 5% 1/4W	
Q22	8-729-422-57	TRANSISTOR UN4111		R38	1-249-427-11	CARBON 6.8K 5% 1/4W	
Q24	8-729-422-57	TRANSISTOR UN4111		R39	1-249-417-11	CARBON 1K 5% 1/4W	
Q151	8-729-904-36	TRANSISTOR DTC114YS		R41	1-247-863-11	CARBON 22K 5% 1/4W	
Q251	8-729-904-36	TRANSISTOR DTC114YS		R42	1-249-437-11	CARBON 47K 5% 1/4W	
Q501	8-729-904-36	TRANSISTOR DTC114YS		R43	1-249-437-11	CARBON 47K 5% 1/4W	
Q502	8-729-119-78	TRANSISTOR 2SC2785-HFE		R44	1-249-429-11	CARBON 10K 5% 1/4W	
				R51	1-249-441-11	CARBON 100K 5% 1/4W	
				R52	1-249-441-11	CARBON 100K 5% 1/4W	
				R53	1-249-441-11	CARBON 100K 5% 1/4W	

The components identified by mark △ or dotted line with mark △ are critical for safety.
Replace only with part number specified.

Ref. No.	Part No.	Description			Remark	Ref. No.	Part No.	Description			Remark
R61	1-249-427-11	CARBON	6.8K	5%	1/4W	R505	1-249-429-11	CARBON	10K	5%	1/4W
R62	1-249-434-11	CARBON	27K	5%	1/4W	R506	1-249-425-11	CARBON	4.7K	5%	1/4W
R63	1-249-427-11	CARBON	6.8K	5%	1/4W	R507	1-247-895-00	CARBON	470K	5%	1/4W
R64	1-249-434-11	CARBON	27K	5%	1/4W	R508	1-249-417-11	CARBON	1K	5%	1/4W
R70	1-247-887-00	CARBON	220K	5%	1/4W	R510	1-249-429-11	CARBON	10K	5%	1/4W
R72	1-249-417-11	CARBON	1K	5%	1/4W	R955	1-249-429-11	CARBON	10K	5%	1/4W
R77	1-249-421-11	CARBON	2.2K	5%	1/4W	R958	1-249-441-11	CARBON	100K	5%	1/4W
R78	1-249-417-11	CARBON	1K	5%	1/4W	R959	1-249-421-11	CARBON	2.2K	5%	1/4W
R79	1-247-863-11	CARBON	22K	5%	1/4W			< SWITCH >			
R81	1-249-409-11	CARBON	220	5%	1/4W	S351	1-554-088-00	SWITCH, KEY BOARD (RESET SW)			
R151	1-247-843-11	CARBON	3.3K	5%	1/4W			< FILTER >			
R152	1-247-863-11	CARBON	22K	5%	1/4W	T151	1-239-503-11	FILTER, LOW PASS			
R153	1-249-428-11	CARBON	8.2K	5%	1/4W	T251	1-239-503-11	FILTER, LOW PASS			
R154	1-247-863-11	CARBON	22K	5%	1/4W			< TERMINAL >			
R155	1-249-432-11	CARBON	18K	5%	1/4W	TB1	1-537-489-21	TERMINAL BOARD (ANT) (ANTENNA)			
R156	1-249-426-11	CARBON	5.6K	5%	1/4W	* TB355	1-536-708-71	TERMINAL BOARD, PUSH 4P (SPEAKER)			
R157	1-249-430-11	CARBON	12K	5%	1/4W			< TUNER >			
R158	1-249-431-11	CARBON	15K	5%	1/4W	* TU1	1-473-650-11	TUNER UNIT			
R159	1-249-425-11	CARBON	4.7K	5%	1/4W			< VIBRATOR >			
R160	1-249-417-11	CARBON	1K	5%	1/4W	X1	1-760-130-11	VIBRATOR, CRYSTAL (75kHz)			
R162	1-249-389-11	CARBON	4.7	5%	1/4W			*****			
R163	1-249-389-11	CARBON	4.7	5%	1/4W	* A-3305-717-A	POWER BOARD, COMPLETE				
R170	1-249-426-11	CARBON	5.6K	5%	1/4W			*****			
R171	1-249-431-11	CARBON	15K	5%	1/4W	1-533-313-11	HOLDER, FUSE				
R173	1-249-429-11	CARBON	10K	5%	1/4W			< CAPACITOR >			
R174	1-249-417-11	CARBON	1K	5%	1/4W	C181	1-136-165-00	FILM	0.1uF	5%	50V
R251	1-247-843-11	CARBON	3.3K	5%	1/4W	C182	1-136-165-00	FILM	0.1uF	5%	50V
R252	1-247-863-11	CARBON	22K	5%	1/4W	C281	1-136-165-00	FILM	0.1uF	5%	50V
R253	1-249-428-11	CARBON	8.2K	5%	1/4W	C282	1-136-165-00	FILM	0.1uF	5%	50V
R254	1-247-863-11	CARBON	22K	5%	1/4W	C301	1-126-961-11	ELECT	2.2uF	20%	50V
R255	1-249-432-11	CARBON	18K	5%	1/4W	C302	1-162-301-11	CERAMIC	0.0015uF	30%	16V
R256	1-249-426-11	CARBON	5.6K	5%	1/4W	C303	1-127-508-00	ELECT(SOLID)	2.2uF	20%	25V
R257	1-249-430-11	CARBON	12K	5%	1/4W	C304	1-104-664-11	ELECT	47uF	20%	25V
R258	1-249-431-11	CARBON	15K	5%	1/4W	C305	1-104-663-11	ELECT	33uF	20%	16V
R259	1-249-425-11	CARBON	4.7K	5%	1/4W	C306	1-162-306-11	CERAMIC	0.01uF	30%	16V
R260	1-249-417-11	CARBON	1K	5%	1/4W	C351	1-104-663-11	ELECT	33uF	20%	16V
R262	1-249-389-11	CARBON	4.7	5%	1/4W	C395	1-124-907-11	ELECT	10uF	20%	50V
R263	1-249-389-11	CARBON	4.7	5%	1/4W	C396	1-162-306-11	CERAMIC	0.01uF	30%	16V
R270	1-249-426-11	CARBON	5.6K	5%	1/4W	C907	1-124-907-11	ELECT	10uF	20%	50V
R271	1-249-431-11	CARBON	15K	5%	1/4W	C913	1-162-306-11	CERAMIC	0.01uF	30%	16V
R273	1-249-429-11	CARBON	10K	5%	1/4W	C915	1-161-494-00	CERAMIC	0.022uF		25V
R274	1-249-417-11	CARBON	1K	5%	1/4W	C916	1-161-494-00	CERAMIC	0.022uF		25V
R351	1-247-807-11	CARBON	100	5%	1/4W	C917	1-161-494-00	CERAMIC	0.022uF		25V
R352	1-249-429-11	CARBON	10K	5%	1/4W	C918	1-161-494-00	CERAMIC	0.022uF		25V
R353	1-249-429-11	CARBON	10K	5%	1/4W						
R355	1-247-807-11	CARBON	100	5%	1/4W						
R356	1-247-870-11	CARBON	43K	5%	1/4W						
R359	1-249-429-11	CARBON	10K	5%	1/4W						
R360	1-249-429-11	CARBON	10K	5%	1/4W						
R361	1-249-429-11	CARBON	10K	5%	1/4W						
R382	1-249-429-11	CARBON	10K	5%	1/4W						
R504	1-249-429-11	CARBON	10K	5%	1/4W						

POWER RELAY

Ref. No.	Part No.	Description	Remark
C919	1-136-165-00	FILM 0.1uF 5% 50V	
C920	1-124-636-00	ELECT 3300uF 20% 25V	
C951	1-117-207-11	ELECT 6800uF 20% 25V	
C953	1-104-666-11	ELECT 220uF 20% 10V	
C954	1-104-664-11	ELECT 47uF 20% 10V	
C955	1-104-666-11	ELECT 220uF 20% 10V	
C956	1-124-120-11	ELECT 220uF 20% 25V	
C957	1-161-772-11	CERAMIC 0.1uF 10% 25V	
C958	1-161-772-11	CERAMIC 0.1uF 10% 25V	
C959	1-136-165-00	FILM 0.1uF 5% 50V	
C960	1-136-165-00	FILM 0.1uF 5% 50V	
C961	1-161-772-11	CERAMIC 0.1uF 10% 25V	
C962	1-124-478-11	ELECT 100uF 20% 25V	
< CONNECTOR >			
CN351	1-565-731-11	PLUG, CONNECTOR (2.5MM) 5P	
CN352	1-691-041-21	HOUSING, CONNECTOR 9P	
CN903	1-564-505-11	PLUG, CONNECTOR 2P	
CN904	1-691-047-21	HOUSING, CONNECTOR 15P	
CN905	1-569-596-11	PLUG, CONNECTOR (2.5MM) 3P	
* CN951	1-506-986-11	PIN, CONNECTOR (PC BOARD) 4P	
CN952	1-566-690-11	PLUG, CONNECTOR (2.5MM) 2P	
< DIODE >			
D352	8-719-060-46	DIODE SB10-05A2	
D390	8-719-109-63	DIODE RD3.0ESB2	
D915	8-719-970-02	DIODE 1SR139-400	
D916	8-719-970-02	DIODE 1SR139-400	
D917	8-719-970-02	DIODE 1SR139-400	
D918	8-719-970-02	DIODE 1SR139-400	
< FUSE >			
△ F902	1-533-468-11	FUSE, GLASS TUBE (DIA. 5) (2A/250V)	
< IC >			
IC354	8-759-427-34	IC LA4905	
IC951	8-759-996-77	IC BA3924	
IC952	8-759-604-36	IC M5F78M08L	
IC953	8-759-324-40	IC KIA7805PI	
< COIL >			
L351	1-411-913-11	COIL, CHOKE	
< IC LINK >			
△ PS951	1-532-727-11	LINK, IC 0.25A	
△ PS952	1-532-605-00	LINK, IC 0.4A	
△ PS953	1-532-605-00	LINK, IC 0.4A	
< TRANSISTOR >			
Q302	8-729-904-36	TRANSISTOR DTC114YS	

Ref. No.	Part No.	Description	Remark
Q356	8-729-142-46	TRANSISTOR 2SC2001-LK	
Q357	8-729-119-78	TRANSISTOR 2SC403SP-51	
Q358	8-729-039-02	TRANSISTOR 2SD1668-S	
Q390	8-729-801-84	TRANSISTOR 2SB1013-4	
Q391	8-729-119-78	TRANSISTOR 2SC403SP-51	
Q392	8-729-119-78	TRANSISTOR 2SC403SP-51	
Q393	8-729-900-65	TRANSISTOR DTA144ES	
Q951	8-729-024-94	TRANSISTOR 2SB1565F	
< RESISTOR >			
R166	1-249-417-11	CARBON 1K 5% 1/4W	
R168	1-249-385-11	CARBON 2.2 5% 1/6W	
R169	1-249-385-11	CARBON 2.2 5% 1/6W	
R266	1-249-417-11	CARBON 1K 5% 1/4W	
R268	1-249-385-11	CARBON 2.2 5% 1/6W	
R269	1-249-385-11	CARBON 2.2 5% 1/6W	
R301	1-247-843-11	CARBON 3.3K 5% 1/4W	
R358	1-249-429-11	CARBON 10K 5% 1/4W	
△ R362	1-216-476-11	METAL OXIDE 180 5% 3W F	
R363	1-249-429-11	CARBON 10K 5% 1/4W	
R365	1-249-441-11	CARBON 100K 5% 1/4W	
R366	1-249-439-11	CARBON 68K 5% 1/4W	
△ R367	1-217-639-00	FUSIBLE 2.2 5% 1/4W F	
R390	1-249-426-11	CARBON 5.6K 5% 1/4W	
R391	1-247-832-11	CARBON 1.1K 5% 1/4W	
R392	1-249-413-11	CARBON 470 5% 1/4W	
R393	1-249-417-11	CARBON 1K 5% 1/4W	
R394	1-249-426-11	CARBON 5.6K 5% 1/4W	
R902	1-249-429-11	CARBON 10K 5% 1/4W	

*	1-641-566-21	RELAY BOARD *****	
*	3-380-110-01	HOLDER, PHOTO	
< CONNECTOR >			
CN691	1-565-937-11	SOCKET, CONNECTOR 13P	
* CN692	1-566-001-11	PIN, CONNECTOR (PC BOARD) 4P BOARD	
< DIODE >			
D691	8-719-991-33	DIODE 1SS133T-77	
D692	8-719-991-33	DIODE 1SS133T-77	
< PHOTO INTERRUPTER >			
PH691	8-719-710-03	PHOTO REFLECTOR NJL5165K-B	
< SWITCH >			
S691	1-572-248-11	SWITCH, LEAF (HALF)	
S692	1-572-248-11	SWITCH, LEAF (CrO2)	
S693	1-572-248-11	SWITCH, LEAF (METAL)	
S694	1-572-248-11	SWITCH, LEAF (ERASE PROOF SIDE A)	
S695	1-572-248-11	SWITCH, LEAF (ERASE PROOF SIDE B)	

The components identified by mark △ or dotted line with mark △ are critical for safety.
Replace only with part number specified.

Ref. No.	Part No.	Description	Remark			
S696	1-692-163-11	SWITCH, MICRO (HEAD POSITION)				

*	1-660-672-11	SW BOARD	*****			
		< CAPACITOR >				
C401	1-162-306-11	CERAMIC	0.01uF	30%	16V	
C402	1-126-160-11	ELECT	1uF	20%	50V	
C403	1-162-294-31	CERAMIC	0.001uF	10%	50V	
		< CONNECTOR >				
CN401	1-766-797-11	CONNECTOR, BOARD TO BOARD 10P				
		< DIODE >				
D402	8-719-991-33	DIODE 1SS133T-77				
D403	8-719-991-33	DIODE 1SS133T-77				
		< IC >				
IC401	8-749-011-05	IC GP1U28X				
		< JACK >				
J401	1-573-191-11	JACK (♁)				
		< COIL >				
L401	1-414-146-31	INDUCTOR	2.2uH			
L402	1-414-146-31	INDUCTOR	2.2uH			
L403	1-414-146-31	INDUCTOR	2.2uH			
L404	1-414-146-31	INDUCTOR	2.2uH			
L405	1-414-146-31	INDUCTOR	2.2uH			
L406	1-414-146-31	INDUCTOR	2.2uH			
L407	1-414-146-31	INDUCTOR	2.2uH			
L408	1-410-517-11	INDUCTOR	47uH			
L409	1-414-146-31	INDUCTOR	2.2uH			
L410	1-410-517-11	INDUCTOR	47uH			
		< RESISTOR >				
R401	1-249-415-11	CARBON	680	5%	1/4W	
R402	1-249-416-11	CARBON	820	5%	1/4W	
R403	1-249-418-11	CARBON	1.2K	5%	1/4W	
R404	1-249-420-11	CARBON	1.8K	5%	1/4W	
R405	1-247-843-11	CARBON	3.3K	5%	1/4W	
R406	1-249-427-11	CARBON	6.8K	5%	1/4W	
R407	1-249-415-11	CARBON	680	5%	1/4W	
R408	1-249-416-11	CARBON	820	5%	1/4W	
R409	1-249-418-11	CARBON	1.2K	5%	1/4W	
R410	1-249-420-11	CARBON	1.8K	5%	1/4W	
R411	1-247-843-11	CARBON	3.3K	5%	1/4W	
R412	1-249-418-11	CARBON	1.2K	5%	1/4W	
R413	1-249-420-11	CARBON	1.8K	5%	1/4W	
R414	1-247-843-11	CARBON	3.3K	5%	1/4W	
R415	1-249-425-11	CARBON	4.7K	5%	1/4W	

Ref. No.	Part No.	Description	Remark			
R416	1-249-425-11	CARBON	4.7K	5%	1/4W	
		< SWITCH >				
S401	1-572-199-11	SWITCH, KEY BOARD (POWER)				
S402	1-554-088-00	SWITCH, KEY BOARD (▷)				
S403	1-554-088-00	SWITCH, KEY BOARD (CD)				
S404	1-572-199-11	SWITCH, KEY BOARD (▷)				
S405	1-572-199-11	SWITCH, KEY BOARD (TAPE □)				
S406	1-572-199-11	SWITCH, KEY BOARD (<◁)				
S407	1-572-199-11	SWITCH, KEY BOARD (BAND)				
S408	1-572-199-11	SWITCH, KEY BOARD (PRESET +)				
S409	1-572-199-11	SWITCH, KEY BOARD (PRESET -)				
S410	1-572-199-11	SWITCH, KEY BOARD (TUNING +)				
S411	1-572-199-11	SWITCH, KEY BOARD (TUNING -)				
S412	1-572-199-11	SWITCH, KEY BOARD (●)				
S413	1-572-199-11	SWITCH, KEY BOARD (DUBBING)				
S414	1-572-199-11	SWITCH, KEY BOARD (VOLUME -)				
S415	1-572-199-11	SWITCH, KEY BOARD (VOLUME +)				
S416	1-572-199-11	SWITCH, KEY BOARD (▷▷)				
S417	1-572-199-11	SWITCH, KEY BOARD (<◁◁)				

*	A-3305-436-A	TC BOARD, COMPLETE	*****			
		< CAPACITOR >				
C103	1-163-006-11	CERAMIC CHIP	560PF	10%	50V	
C106	1-124-443-00	ELECT	100uF	20%	10V	
C107	1-104-555-11	FILM CHIP	0.022uF	5%	16V	
C119	1-164-346-11	CERAMIC CHIP	1uF		16V	
C120	1-163-117-00	CERAMIC CHIP	100PF	5%	50V	
C121	1-164-346-11	CERAMIC CHIP	1uF		16V	
C122	1-163-139-00	CERAMIC CHIP	820PF	5%	50V	
C123	1-110-647-11	CERAMIC CHIP	150PF	5%	200V	
C124	1-163-001-11	CERAMIC CHIP	220PF	10%	50V	
C125	1-124-907-11	ELECT	10uF	20%	50V	
C134	1-104-543-11	FILM CHIP	0.0022uF	5%	50V	
C135	1-104-547-11	FILM CHIP	0.0047uF	5%	16V	
C203	1-163-006-11	CERAMIC CHIP	560PF	10%	50V	
C206	1-124-443-00	ELECT	100uF	20%	10V	
C207	1-104-555-11	FILM CHIP	0.022uF	5%	16V	
C219	1-164-346-11	CERAMIC CHIP	1uF		16V	
C220	1-163-117-00	CERAMIC CHIP	100PF	5%	50V	
C221	1-164-346-11	CERAMIC CHIP	1uF		16V	
C222	1-163-139-00	CERAMIC CHIP	820PF	5%	50V	
C223	1-110-647-11	CERAMIC CHIP	150PF	5%	200V	
C224	1-163-001-11	CERAMIC CHIP	220PF	10%	50V	
C225	1-124-907-11	ELECT	10uF	20%	50V	
C234	1-104-543-11	FILM CHIP	0.0022uF	5%	50V	
C235	1-104-547-11	FILM CHIP	0.0047uF	5%	16V	
C301	1-124-443-00	ELECT	100uF	20%	10V	
C302	1-126-963-11	ELECT	4.7uF	20%	50V	

Ref. No.	Part No.	Description			Remark
C303	1-124-907-11	ELECT	10uF	20%	50V
C304	1-124-907-11	ELECT	10uF	20%	50V
C305	1-124-907-11	ELECT	10uF	20%	50V
C307	1-124-443-00	ELECT	100uF	20%	10V
C308	1-126-963-11	ELECT	4.7uF	20%	50V
C309	1-124-443-00	ELECT	100uF	20%	10V
C313	1-124-443-00	ELECT	100uF	20%	10V
C316	1-164-232-11	CERAMIC CHIP	0.01uF		50V
C318	1-124-443-00	ELECT	100uF	20%	10V
C319	1-163-011-11	CERAMIC CHIP	0.0015uF	10%	50V
C320	1-164-182-11	CERAMIC CHIP	0.0033uF	10%	50V
C321	1-130-848-00	FILM	0.0082uF	5%	100V
C322	1-137-385-11	FILM	470PF	5%	100V
C323	1-137-387-11	FILM	0.001uF	5%	100V
C324	1-163-037-11	CERAMIC CHIP	0.022uF	10%	25V
C325	1-163-037-11	CERAMIC CHIP	0.022uF	10%	25V
C336	1-163-011-11	CERAMIC CHIP	0.0015uF	10%	50V
C337	1-126-961-11	ELECT	2.2uF	20%	50V
C338	1-124-903-11	ELECT	1uF	20%	50V
C343	1-164-004-11	CERAMIC CHIP	0.1uF	10%	25V
C344	1-126-963-11	ELECT	4.7uF	20%	50V
C601	1-124-907-11	ELECT	10uF	20%	50V
C602	1-124-907-11	ELECT	10uF	20%	50V
C603	1-126-233-11	ELECT	22uF	20%	50V
C604	1-124-903-11	ELECT	1uF	20%	50V
< CONNECTOR >					
CN301	1-770-527-31	CONNECTOR, FFC/FPC 20P			
CN302	1-695-017-11	HOUSING, CONNECTOR 7P			
CN303	1-695-368-31	CONNECTOR, FFC/FPC 7P			
CN306	1-691-072-11	HOUSING, CONNECTOR 13P			
< IC >					
IC301	8-759-249-21	IC uPC1330AGR			
IC302	8-759-382-00	IC BA3443KS			
< JUMPER RESISTOR >					
JC320	1-216-296-00	METAL CHIP	0	5%	1/8W
JC322	1-216-295-00	METAL CHIP	0	5%	1/10W
< COIL >					
L102	1-410-776-11	INDUCTOR	12mH		
L202	1-410-776-11	INDUCTOR	12mH		
L301	1-410-482-31	INDUCTOR	100uH		
< IC LINK >					
△ PS601	1-576-123-21	LINK, IC			
< TRANSISTOR >					
Q303	8-729-101-07	TRANSISTOR 2SB798-DL			
Q305	8-729-800-34	TRANSISTOR 2SC3070			

Ref. No.	Part No.	Description			Remark
Q308	8-729-105-37	TRANSISTOR 2SC3360			
Q309	8-729-105-37	TRANSISTOR 2SC3360			
Q311	8-729-120-28	TRANSISTOR 2SC1623-L5L6			
Q601	8-729-900-52	TRANSISTOR DTC114YK			
Q602	8-729-202-56	TRANSISTOR 2SA950-Y			
Q603	8-729-902-99	TRANSISTOR DTC114TK			
Q604	8-729-116-57	TRANSISTOR 2SB1068-K			
Q605	8-729-900-52	TRANSISTOR DTC114YK			
< RESISTOR >					
R101	1-216-295-00	METAL CHIP	0	5%	1/10W
R102	1-216-049-11	METAL GLAZE	1K	5%	1/10W
R103	1-216-023-00	METAL CHIP	82	5%	1/10W
R104	1-216-295-00	METAL CHIP	0	5%	1/10W
R112	1-216-075-00	METAL CHIP	12K	5%	1/10W
R113	1-216-073-00	METAL CHIP	10K	5%	1/10W
R116	1-216-093-00	METAL CHIP	68K	5%	1/10W
R201	1-216-295-00	METAL CHIP	0	5%	1/10W
R202	1-216-049-11	METAL GLAZE	1K	5%	1/10W
R203	1-216-023-00	METAL CHIP	82	5%	1/10W
R204	1-216-295-00	METAL CHIP	0	5%	1/10W
R212	1-216-075-00	METAL CHIP	12K	5%	1/10W
R213	1-216-073-00	METAL CHIP	10K	5%	1/10W
R216	1-216-093-00	METAL CHIP	68K	5%	1/10W
R301	1-216-025-00	METAL GLAZE	100	5%	1/10W
R302	1-216-089-00	METAL GLAZE	47K	5%	1/10W
R303	1-216-065-00	METAL CHIP	4.7K	5%	1/10W
R304	1-216-025-00	METAL GLAZE	100	5%	1/10W
R305	1-216-083-00	METAL CHIP	27K	5%	1/10W
R306	1-216-085-00	METAL CHIP	33K	5%	1/10W
R307	1-216-049-11	METAL GLAZE	1K	5%	1/10W
R308	1-216-097-00	METAL GLAZE	100K	5%	1/10W
R309	1-216-097-00	METAL GLAZE	100K	5%	1/10W
R311	1-218-179-11	METAL GLAZE	10M	5%	1/10W
R312	1-216-073-00	METAL CHIP	10K	5%	1/10W
R313	1-216-295-00	METAL CHIP	0	5%	1/10W
R314	1-216-073-00	METAL CHIP	10K	5%	1/10W
R320	1-216-025-00	METAL GLAZE	100	5%	1/10W
R321	1-216-085-00	METAL CHIP	33K	5%	1/10W
R325	1-216-057-00	METAL CHIP	2.2K	5%	1/10W
R326	1-216-057-00	METAL CHIP	2.2K	5%	1/10W
R344	1-216-081-00	METAL CHIP	22K	5%	1/10W
R345	1-216-077-00	METAL CHIP	15K	5%	1/10W
R346	1-216-077-00	METAL CHIP	15K	5%	1/10W
R347	1-216-105-91	METAL GLAZE	220K	5%	1/10W
R601	1-216-073-00	METAL CHIP	10K	5%	1/10W
R602	1-216-037-00	METAL CHIP	330	5%	1/10W
R603	1-216-073-00	METAL CHIP	10K	5%	1/10W
R604	1-216-073-00	METAL CHIP	10K	5%	1/10W
R605	1-216-073-00	METAL CHIP	10K	5%	1/10W
R606	1-216-073-00	METAL CHIP	10K	5%	1/10W
R607	1-216-097-00	METAL GLAZE	100K	5%	1/10W

The components identified by mark △ or dotted line with mark △ are critical for safety.
Replace only with part number specified.

Ref. No.	Part No.	Description	Remark
R608	1-216-097-00	METAL GLAZE 100K 5%	1/10W
R609	1-216-049-11	METAL GLAZE 1K 5%	1/10W
R610	1-216-097-00	METAL GLAZE 100K 5%	1/10W
R611	1-216-049-11	METAL GLAZE 1K 5%	1/10W
R612	1-216-097-00	METAL GLAZE 100K 5%	1/10W
R613	1-216-097-00	METAL GLAZE 100K 5%	1/10W
R614	1-216-097-00	METAL GLAZE 100K 5%	1/10W
R615	1-216-097-00	METAL GLAZE 100K 5%	1/10W
R616	1-216-049-11	METAL GLAZE 1K 5%	1/10W
< VARIABLE RESISTOR >			
RV102	1-238-019-11	RES, ADJ, CARBON 47K (PB LEVEL L)	
RV103	1-238-019-11	RES, ADJ, CARBON 47K (REC LEVEL L)	
RV104	1-238-019-11	RES, ADJ, CARBON 47K (BIAS)	
RV202	1-238-019-11	RES, ADJ, CARBON 47K (PB LEVEL R)	
RV203	1-238-019-11	RES, ADJ, CARBON 47K (REC LEVEL R)	
RV204	1-238-019-11	RES, ADJ, CARBON 47K (BIAS)	
RV601	1-241-762-11	RES, ADJ, CARBON 2.2K (TAPE SPEED)	
< TRANSFORMER >			
T301	1-433-391-11	TRANSFORMER, BIAS OSCILLATOR	

*	A-3305-718-A	VOL BOARD, COMPLETE	

< CAPACITOR >			
C163	1-136-165-00	FILM 0.1uF 5%	50V
C164	1-136-165-00	FILM 0.1uF 5%	50V
C165	1-162-294-31	CERAMIC 0.001uF 10%	50V
C173	1-136-165-00	FILM 0.1uF 5%	50V
C174	1-104-664-11	ELECT 47uF 20%	10V
C175	1-162-286-21	CERAMIC 220PF 10%	50V
C176	1-124-443-00	ELECT 100uF 20%	10V
C179	1-126-961-11	ELECT 2.2uF 20%	50V
C188	1-124-903-11	ELECT 1uF 20%	50V
C263	1-136-165-00	FILM 0.1uF 5%	50V
C264	1-136-165-00	FILM 0.1uF 5%	50V
C265	1-162-294-31	CERAMIC 0.001uF 10%	50V
C273	1-136-165-00	FILM 0.1uF 5%	50V
C274	1-104-664-11	ELECT 47uF 20%	10V
C275	1-162-286-21	CERAMIC 220PF 10%	50V
C276	1-124-443-00	ELECT 100uF 20%	10V
C279	1-126-961-11	ELECT 2.2uF 20%	50V
C288	1-124-903-11	ELECT 1uF 20%	50V
C354	1-124-443-00	ELECT 100uF 20%	10V
C355	1-162-294-31	CERAMIC 0.001uF 10%	50V
C356	1-162-294-31	CERAMIC 0.001uF 10%	50V
C357	1-162-294-31	CERAMIC 0.001uF 10%	50V
C371	1-124-472-11	ELECT 470uF 20%	10V
C373	1-104-666-11	ELECT 220uF 20%	6.3V
C374	1-136-165-00	FILM 0.1uF 5%	50V

Ref. No.	Part No.	Description	Remark
C375	1-126-233-11	ELECT 22uF 20%	50V
C376	1-136-165-00	FILM 0.1uF 5%	50V
C377	1-124-907-11	ELECT 10uF 20%	50V
C378	1-124-443-00	ELECT 100uF 20%	10V
C380	1-104-666-11	ELECT 220uF 20%	6.3V
C383	1-161-055-00	CERAMIC 0.022uF 10%	50V
C384	1-136-153-00	FILM 0.01uF 5%	50V
C394	1-124-903-11	ELECT 1uF 20%	50V
< CONNECTOR >			
CN353	1-691-041-21	HOUSING, CONNECTOR 9P	
CN354	1-691-043-21	HOUSING, CONNECTOR 11P	
< DIODE >			
D351	8-719-991-33	DIODE 1SS133T-77	
< IC >			
IC351	8-759-332-62	IC BH3854S	
IC353	8-759-701-54	IC NJM2073D	
< TRANSISTOR >			
Q351	8-729-119-78	TRANSISTOR 2SC403SP-51	
Q352	8-729-902-80	TRANSISTOR DTA114YS	
Q353	8-729-902-80	TRANSISTOR DTA114YS	
Q354	8-729-902-80	TRANSISTOR DTA114YS	
Q355	8-729-119-78	TRANSISTOR 2SC403SP-51	
< RESISTOR >			
R161	1-249-385-11	CARBON 2.2 5%	1/6W
R164	1-247-843-11	CARBON 3.3K 5%	1/4W
R165	1-249-417-11	CARBON 1K 5%	1/4W
R172	1-249-415-11	CARBON 680 5%	1/4W
R175	1-249-417-11	CARBON 1K 5%	1/4W
R176	1-249-417-11	CARBON 1K 5%	1/4W
R177	1-249-417-11	CARBON 1K 5%	1/4W
R178	1-249-417-11	CARBON 1K 5%	1/4W
R261	1-249-385-11	CARBON 2.2 5%	1/6W
R264	1-247-843-11	CARBON 3.3K 5%	1/4W
R265	1-249-417-11	CARBON 1K 5%	1/4W
R272	1-249-415-11	CARBON 680 5%	1/4W
R275	1-249-417-11	CARBON 1K 5%	1/4W
R276	1-249-417-11	CARBON 1K 5%	1/4W
R277	1-249-417-11	CARBON 1K 5%	1/4W
R278	1-249-417-11	CARBON 1K 5%	1/4W
R354	1-247-807-11	CARBON 100 5%	1/4W
R357	1-249-401-11	CARBON 47 5%	1/4W
R373	1-247-903-00	CARBON 1M 5%	1/4W
R374	1-247-807-11	CARBON 100 5%	1/4W
R375	1-249-429-11	CARBON 10K 5%	1/4W
R376	1-249-429-11	CARBON 10K 5%	1/4W
R377	1-249-429-11	CARBON 10K 5%	1/4W
R378	1-247-903-00	CARBON 1M 5%	1/4W

VOL

Ref. No.	Part No.	Description	Remark
R379	1-249-429-11	CARBON 10K 5%	1/4W
R380	1-249-417-11	CARBON 1K 5%	1/4W
R383	1-249-417-11	CARBON 1K 5%	1/4W
R384	1-249-437-11	CARBON 47K 5%	1/4W
R385	1-247-895-00	CARBON 470K 5%	1/4W

MISCELLANEOUS			

2	1-776-441-11	WIRE, PARALLEL (FFC) (9 CORE)	
3	1-533-313-11	HOLDER, FUSE	
7	1-776-439-11	WIRE, PARALLEL (FFC) (15 CORE)	
8	1-776-440-11	WIRE, PARALLEL (FFC) (11 CORE)	
71	1-776-037-11	WIRE, PARALLEL (FFC) (11 CORE)	
75	1-776-039-11	WIRE, PARALLEL (FFC) (15 CORE)	
76	1-776-040-11	WIRE, PARALLEL (FFC) (12 CORE)	
77	1-776-036-11	WIRE, PARALLEL (FFC) (7 CORE)	
79	1-765-435-11	WIRE, PARALLEL (FFC) (13 CORE)	
80	1-776-038-11	WIRE, PARALLEL (FFC) (20 CORE)	
* 84	1-661-719-11	PC BOARD, RETAINER	
103	1-452-732-11	MAGNET	
114	1-769-828-11	WIRE (FLAT TYPE) (16 CORE)	
252	X-2625-770-1	CHASSIS ASSY, MOTOR (SPINDLE)	(including M702)
△ 254	8-848-367-11	OPTICAL PICK-UP KSS-213B/K-N	
△ CNP901	1-575-651-11	CORD, POWER (AEP,German,Italian)	
△ CNP901	1-696-570-21	CORD, POWER (UK)	
△ F901	1-533-472-11	FUSE, GLASS TUBE (DIA. 5)(5A/250V)	
△ F902	1-533-468-11	FUSE, GLASS TUBE (DIA. 5) (2A/250V)	
HRPE3011	1-543-991-11	HEAD, MAGNETIC (REC/PLAY/ERASE)	
M691	A-3263-138-A	MOTOR ASSY (REEL/CAPSTAN)	
M701	X-2625-769-1	GEAR ASSY, MOTOR (SLED)	
ND801	1-801-076-11	DISPLAY PANEL, LIQUID CRYSTAL	
PM691	1-454-595-11	SOLENOID, PLUNGER	
S701	1-571-936-11	SWITCH, LEAF (LIMT SW)	
S702	1-692-960-11	SWITCH, PUSH (1 KEY) (DOOR OPEN SW)	
SP1	1-505-382-11	SPEAKER (L-CH, R-CH)	
△ T901	1-429-573-11	TRANSFORMER, POWER	

Ref. No.	Part No.	Description	Remark
ACCESSORIES & PACKING MATERIALS			

	1-501-374-11	ANTENNA, LOOP	
	1-501-594-11	ANTENNA (FM)	
	3-856-988-11	MANUAL, INSTRUCTION (ENGLISH, GERMAN)	(AEP,UK,German)
	3-856-988-21	MANUAL, INSTRUCTION (FRENCH, SPANISH)	(AEP)
	3-856-988-31	MANUAL, INSTRUCTION (DUTCH, SWEDISH, PORTUGUESE) (AEP)	
	3-856-988-41	MANUAL, INSTRUCTION (ITALIAN) (Italian)	
*	3-937-209-01	INDIVIDUAL CARTON	
	8-917-530-90	REMOCON, SONY RMT-C303A/M SET	
	4-977-908-01	COVER, BATTERY (FOR RMT-C303A)	

HARDWARE LIST

#1	7-685-647-79	SCREW +BVTP 3X10 TYPE2 N-S
#2	7-685-246-19	SCREW +KTP 3X8 TYPE2 NON-SLIT
#3	7-685-645-79	SCREW (4X6), BVTP
#4	7-685-646-79	SCREW +BVTP 3X8 TYPE2 SLIT
#5	7-685-648-79	SCREW +BVTP 3X12 TYPE2 SLIT
#6	7-621-773-95	SCREW +B 2.6X6
#7	7-685-133-19	SCREW +P 2.6X6 TYPE2 NON-SLIT
#8	7-627-553-97	PRECISION SCREW +P 2X8 TYPE 3
#9	7-685-134-19	SCREW +P 2.6X8 TYPE2 SLIT
#10	7-621-775-08	SCREW +P 2.6X3
#11	7-621-255-15	SCREW +P 2X3

The components identified by mark △ or dotted line with mark △ are critical for safety.
Replace only with part number specified.

PMC-303L

SONY

*AEP Model
UK Model*

SERVICE MANUAL

CORRECTION - 1

Correct your Service Manual as shown below.

8-6. OPTICAL PICK-UP SECTION (KSM-213BAN/S-N)

● : Correct portion

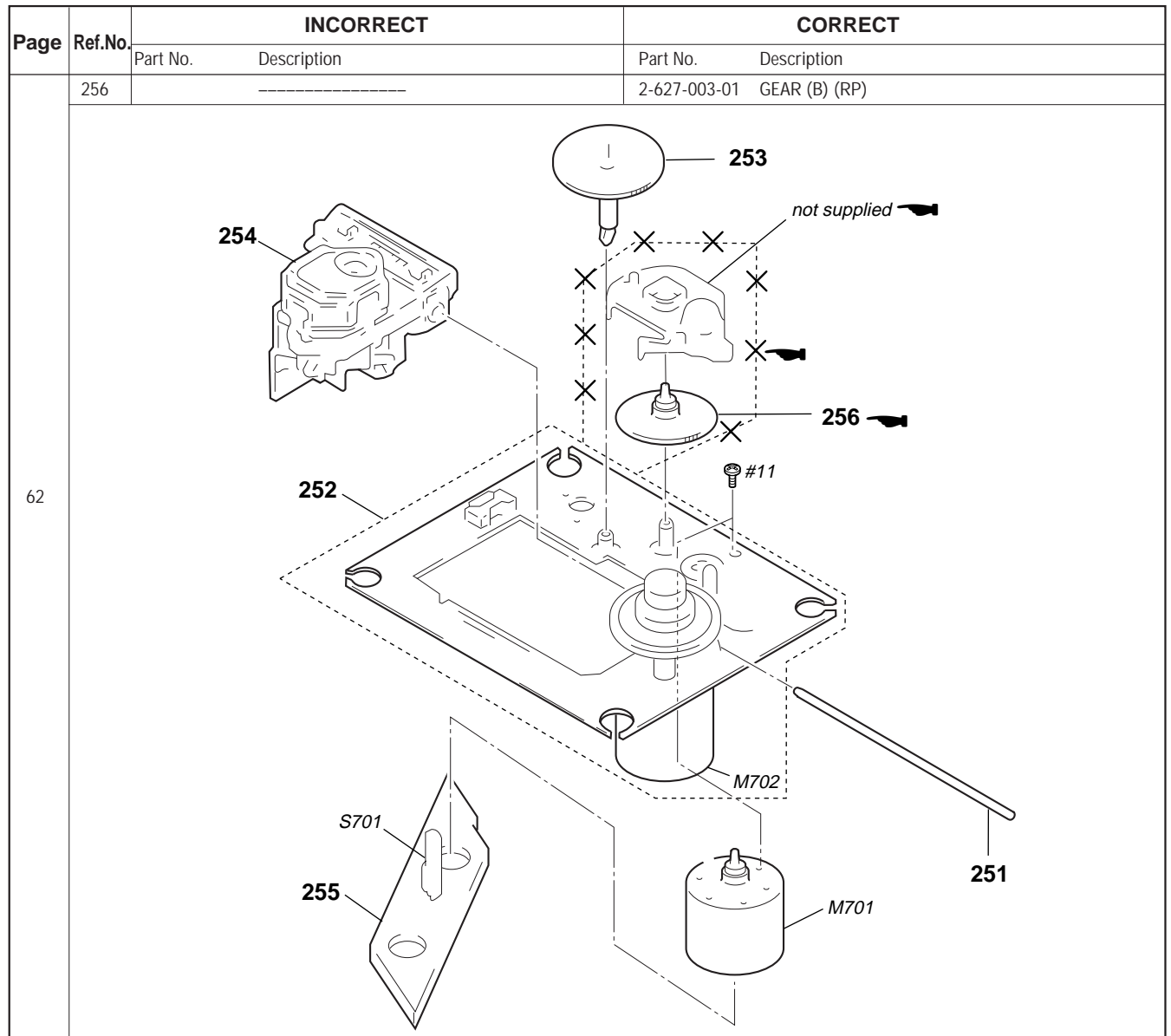

(SPM-97032)